

NEMA SSL 7A-2013

Phase Cut Dimming for Solid State Lighting: Basic Compatibility



NEMA SSL 7A-2013

Phase Cut Dimming for Solid State Lighting: Basic Compatibility

Published by

National Electrical Manufacturers Association

1300 North 17th Street, Suite 900

Rosslyn, Virginia 22209

Approved April 3, 2013

www.nema.org

© Copyright 2013 by the National Electrical Manufacturers Association. All rights including translation into other languages, reserved under the Universal Copyright Convention, the Berne Convention for the Protection of Literary and Artistic Works, and the International and Pan American Copyright Conventions.

NOTICE AND DISCLAIMER

The information in this publication was considered technically sound by the consensus of persons engaged in the development and approval of the document at the time it was developed. Consensus does not necessarily mean that there is unanimous agreement among every person participating in the development of this document.

National Electrical Manufacturers Association (NEMA) standards and guideline publications, of which the document contained herein is one, are developed through a voluntary consensus standards development process. This process brings together volunteers and/or seeks out the views of persons who have an interest in the topic covered by this publication. While NEMA administers the process and establishes rules to promote fairness in the development of consensus, it does not write the document and it does not independently test, evaluate, or verify the accuracy or completeness of any information or the soundness of any judgments contained in its standards and guideline publications.

NEMA disclaims liability for any personal injury, property, or other damages of any nature whatsoever, whether special, indirect, consequential, or compensatory, directly or indirectly resulting from the publication, use of, application, or reliance on this document. NEMA disclaims and makes no guaranty or warranty, expressed or implied, as to the accuracy or completeness of any information published herein, and disclaims and makes no warranty that the information in this document will fulfill any of your particular purposes or needs. NEMA does not undertake to guarantee the performance of any individual manufacturer or seller's products or services by virtue of this standard or guide.

In publishing and making this document available, NEMA is not undertaking to render professional or other services for or on behalf of any person or entity, nor is NEMA undertaking to perform any duty owed by any person or entity to someone else. Anyone using this document should rely on his or her own independent judgment or, as appropriate, seek the advice of a competent professional in determining the exercise of reasonable care in any given circumstances. Information and other standards on the topic covered by this publication may be available from other sources, which the user may wish to consult for additional views or information not covered by this publication.

NEMA has no power, nor does it undertake to police or enforce compliance with the contents of this document. NEMA does not certify, test, or inspect products, designs, or installations for safety or health purposes. Any certification or other statement of compliance with any health or safety-related information in this document shall not be attributable to NEMA and is solely the responsibility of the certifier or maker of the statement.

FOREWORD

The NEMA Solid State Lighting section has prepared this standard, *Phase Cut Dimming for Solid State Lighting: Basic Compatibility*. This standard provides compatibility requirements for phase cut dimming for LED light engines and is suitable for global use.

In the preparation of this standard, input of users and other interested parties has been sought and evaluated. Inquiries, comments, and proposed or recommended revisions should be submitted to the concerned NEMA product subdivision by contacting:

Senior Technical Director, Operations
National Electrical Manufacturers Association
1300 North 17th Street, Suite 900
Rosslyn, Virginia 22209

Section approval of the standard does not necessarily imply that all section members voted for its approval or participated in its development.

At the time the standard was approved, the Solid State Lighting section was composed of the following members:

Acuity Brands Lighting
Cree, Inc.
Dialight Corporation
Eaton Cooper Lighting
EIKO, Ltd.
EYE Lighting International of N.A., Inc.
GE Lighting Solutions
Hatch Transformers, Inc.
Hubbell Lighting, Inc.
Leviton Lighting & Energy Solutions
Lighting Science Group Corporation
Luminus Devices, Inc.
Lutron Electronics Company, Inc.
Optiled Technology LLC
OSRAM SYLVANIA Inc.
Philips Electronic North America
Ruud Lighting Inc. Cree Company
Satco Products, Inc.
Schneider Electric
Soraa Inc.
Technical Consumer Products, Inc.
Terra LUX Inc.
Toshiba LED Lighting
Universal Lighting Technologies

<This Page Intentionally Left Blank >

Currently in preview, click buy full version

TABLE OF CONTENTS

FOREWORD	iii
1 GENERAL	1
1.1 SCOPE	1
1.2 ORGANIZATION	2
1.3 NORMATIVE REFERENCES.....	2
1.4 INFORMATIVE REFERENCES	2
1.5 DEFINITIONS.....	2
2 BACKGROUND	5
2.1 PHASE CONTROL DIMMING.....	5
2.2 LLE/DIMMER COMPATIBILITY FACTORS.....	5
3 DIMMER	7
3.1 GENERAL.....	7
3.2 RATED WATTAGE.....	7
3.3 FORWARD PHASE-CONTROL STABILITY REQUIREMENTS.....	7
3.4 INRUSH CURRENT	7
3.5 REPETITIVE PEAK CURRENT	8
3.6 OVERLOAD.....	8
3.7 REPETITIVE PEAK VOLTAGE.....	8
3.8 MINIMUM ON-STATE CONDUCTION ANGLE	9
3.9 MAXIMUM ON-STATE CONDUCTION ANGLE	9
3.10 OFF-STATE OPERATION	9
3.10.1 Background.....	9
3.10.2 Test.....	9
3.11 ON-STATE DIMMER SUPPLY CURRENT.....	12
3.12 MARKING REQUIREMENTS.....	14
3.12.1 Maximum Rated Wattage.....	14
3.12.2 Minimum Load	14
3.12.3 Off-state.....	14
3.12.4 Operating Voltage.....	14
3.12.5 Dimmers with Multiple Modes	14
4 LLE	15
4.1 PHASE-CONTROL REQUIREMENTS	15
4.2 RATED WATTAGE	15
4.3 POWER FACTOR	15
4.4 MAXIMUM RMS CURRENT.....	15
4.5 INRUSH CURRENT	15
4.6 REPETITIVE PEAK CURRENT	16
4.7 REPETITIVE PEAK VOLTAGE	17
4.8 LIGHT OUTPUT	17
4.8.1 Maximum Light Output on a Dimmer.....	17
4.8.2 Minimum Light Output on a Dimmer.....	17
4.9 OFF-STATE OPERATION	18
4.9.1 Background.....	18
4.9.2 Testing.....	19
4.10 ON-STATE OPERATION	19
4.10.1 Background.....	19
4.10.2 Testing.....	19
4.10.2.1 Type 2 LLE Testing	19
4.10.2.2 Type 1 LLE Testing	19
4.11 MARKING REQUIREMENTS.....	20
4.11.1 RMLO	20

4.11.2	Type	20
5	LLE/DIMMER COMPATIBILITY	21

Annex A CIRCUITS (NORMATIVE) A-1

A.1	LINE CHARACTERISTICS AND CIRCUIT VALUES	A-1
A.2	CIRCUIT 1 (SYNTHETIC LOAD 1 FOR DIMMER FORWARD-PHASE STABILITY, INRUSH CURRENT, REPETITIVE PEAK CURRENT AND OVERLOAD TESTING)	A-5
A.3	CIRCUIT 2 (SYNTHETIC LOAD 2 FOR DIMMER FOR FORWARD-PHASE STABILITY, MAXIMUM AND MINIMUM ON-STATE CONDUCTION ANGLE AND ON-STATE OPERATION TESTING)	A-6
A.4	CIRCUIT 3 (WAVEFORM GENERATOR FOR INRUSH CURRENT)	A-7
A.5	CIRCUIT 4 (WAVEFORM GENERATOR FOR MAXIMUM RMS CURRENT, REPETITIVE PEAK CURRENT, REPETITIVE PEAK VOLTAGE, LIGHT OUTPUT, OFF-STATE OPERATION, ON-STATE OPERATION)	A-8

Section 1 GENERAL

1.1 SCOPE

This standard provides compatibility requirements when a forward phase cut dimmer is combined with one or more dimmable LED Light Engines (LLEs). A LLE, for the purposes of this document comprises one or more LED modules, LED control gear (integral or remote), and a connection to the mains circuit¹. Three configurations of LED light engines are shown below (**Figure 1-1**).

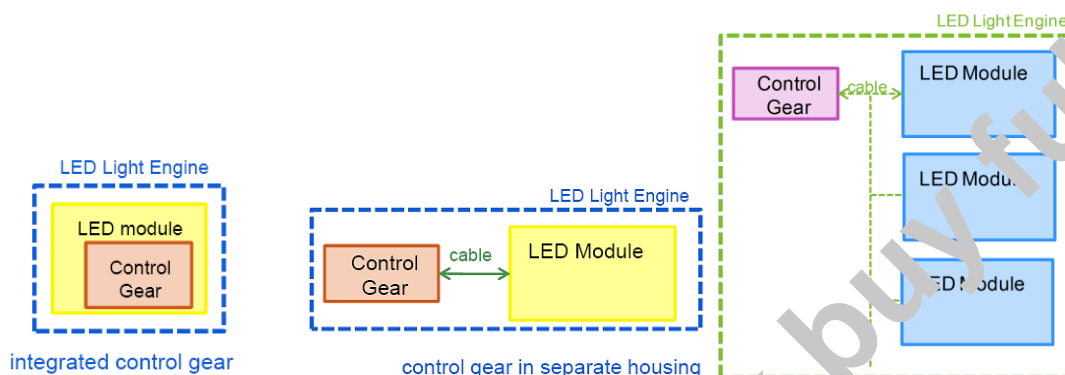

FIGURE 1-1
LED Light Engine

The requirements in this standard do not limit its use to any specific lighting product type or application and is suitable for use globally. For the purposes of this standard, *compatibility* means:

- The reliability of the dimmer and LLE are not affected by combining them.
- Dimming behavior meets or exceeds the behavior specified in sections 3 and 4.

Any interfaces between control gear and LED module(s) within the LLE are undefined in this standard. Such an interface may take a variety of forms. For example, it may be a constant voltage interface, a constant current interface, or a low-voltage AC interface produced by control gear that is simply a step-down electronic transformer. In all cases, compatibility is only defined for the LLE (which may contain one or more specific combinations of control gear and LED module(s)), and not for either component independently. To be considered compliant with this standard, the control gear and modules shall be operated together. This standard does not preclude future standards that will permit separate qualification of control gear and module components, with interfaces defined between them that ensure a proper SSL 7A LLE interface from the point of view of this standard.

This standard is forward-looking and is intended to be used to design and qualify dimmer and LLE products (including integral or remote control gear) for use with each other. It is not intended for use to determine compatibility with existing products or the installed base of LLEs and phase cut dimmers. For information on compatibility with the installed base of dimmers, see SSL 6-2010.

Note: The requirement for compliance to this standard does not supersede applicable international or local regulation.

¹ Through an ANSI/IEC base or a non ANSI/IEC interface.