



IPC-7711C/7721C

Rework, Modification and Repair of Electronic Assemblies

Developed by the Repairability Subcommittee (7-34) of the Product Assurance Committee (7-30) of IPC.

Supersedes:
IPC-7711/7721 with
Changes 1 and 2
Revision B - November 2007
Change 1 - February 2013
Change 2 - March 2014
IPC-7711A/7721A -
October 2003
IPC-R-700C -
January 1988

Users of this publication are encouraged to participate in the development of future revisions.

Contact:



IPC

Table of Contents





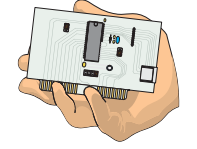

PART 1 General Information and Common Procedures

1 General	1	1.8.8 Hand Held Drilling and Grinding Tool	5
1.1 Scope	1	1.8.9 Precision Drill/Mill System	6
1.2 Purpose	1	1.8.10 Eyelets and Eyelet Press System	7
1.2.1 Definition of Requirements	1	1.8.11 Gold Plating System	8
1.3 Background	1	1.8.12 Tools and Supplies	6
1.4 Terms and Definitions	1	1.8.13 Materials	6
1.4.1 Class of Product	1	1.8.13.1 Solder	6
1.4.2 Board Types	2	1.8.13.2 Flux	6
1.4.3 Skill Level	2	1.8.13.3 Replacement Conductors and Lands	6
1.5 Applicability, Controls and Acceptability	2	1.8.13.4 Epoxy and Coloring Agents	6
1.5.1 Level of Conformance	2	1.8.13.5 Adhesives	6
1.5.1.1 Levels of Conformance	3	1.8.13.6 General	6
1.5.2 Compliance	3	1.8.14 Process Goals and Guidelines	6
1.6 Training	3	1.8.14.1 Non-destructive Component Removal	7
1.7 Basic Considerations	4	1.8.14.1.1 Surface Mount Components	7
1.8 Workstations, Tools, Materials and Processes	4	1.8.14.1.2 Through-Hole Components	7
1.8.1 Electrostatic Discharge (ESD) and Electrical Overstress (EOS) Controls	4	1.8.14.1.3 Component Removal Using Solder Fountain Method	7
1.8.2 Vision Systems	4	1.8.14.2 Component Installation	7
1.8.3 Lighting	4	1.8.14.2.1 Land Preparation	7
1.8.4 Fume Extraction	4	1.8.14.2.2 Surface Mount Components	7
1.8.5 Soldering Tools	4	1.8.14.2.3 Through-Hole Components	8
1.8.6 Primary Heating Methods	5	1.8.15 Cleaning Station/System	8
1.8.6.1 Conductive (by contact) Heating Methods	5	1.8.16 Component Removal and Installation	9
1.8.6.2 Convective (hot gas) and IR (radiant) Heating Methods	5	1.8.17 Conformal Coating Area	9
1.8.7 Preheating (Auxiliary) Heating	5	1.8.18 Selecting a Process	9
		1.8.19 Time Temperature Profile (TTP)	9
		1.9 Lead Free	9

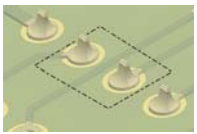

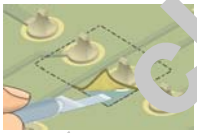
Handling/Cleaning

Procedure	Description	Illustration	Board Type	Skill Level	Level of Conformance
2.1	Handling Electronic Assemblies		N/A	N/A	N/A
2.2	Cleaning		N/A	N/A	N/A

Coating Removal

Procedure	Description	Illustration	Board Type	Skill Level	Level of Conformance
2.3.1	Coating Removal, Identification of Conformal Coating		R, F, W, C	Advanced	High
2.3.2	Coating Removal, Solvent Method		R, F, W, C	Advanced	High
2.3.3	Coating Removal, Peeling Method		R, F, W, C	Advanced	High
2.3.4	Coating Removal, Thermal Method		R, F, W, C	Advanced	High
2.3.5	Coating Removal, Grinding/Scraping Method		R, F, W, C	Advanced	High
2.3.6	Coating Removal, Micro Blasting Method		R, F, W, C	Advanced	High

Coating Replacement

Procedure	Description	Illustration	Board Type	Skill Level	Level of Conformance
2.4.1	Coating Replacement, Solder Resist		R, F, W, C	Intermediate	High
2.4.2	Coating Replacement, Conformal Coatings/Encapsulants		R, F, W, C	Intermediate	High



Conditioning

Procedure	Description	Illustration	Board Type	Skill Level	Level of Conformance
2.5	Baking and Preheating		R, F, W, C	Intermediate	High

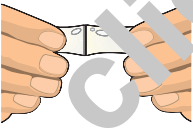
Epoxy Mixing and Handling

Procedure	Description	Illustration	Board Type	Skill Level	Level of Conformance
2.6	Epoxy Mixing and Handling		R, F, W, C	Intermediate	High

Legends/Markings

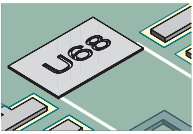
Procedure	Description	Illustration	Board Type	Skill Level	Level of Conformance
2.7.1	Legend/Marking, Stamping Method		R, F, W, C	Intermediate	High
2.7.2	Legend/Marking, Hand Lettering Method		R, F, W, C	Intermediate	High
2.7.3	Legend/Marking, Stencil Method		R, F, W, C	Intermediate	High

Tip Care and Maintenance

Procedure	Description	Illustration	Board Type	Skill Level	Level of Conformance
2.8	Tip Care and Maintenance		N/A	N/A	N/A

Table of Contents

PART 2 Rework

3 Removal

3.1 Through-Hole Desoldering

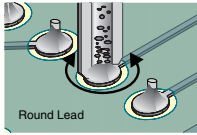
Procedure	Description		Board Type	Skill Level	Level of Conformance
3.1.1	Continuous Vacuum Method		R,F,W	Intermediate	High
3.1.2	Continuous Vacuum Method - Partial Clinch		R,F,W	Intermediate	High
3.1.3	Continuous Vacuum Method - Full Clinch		R,F,W	Intermediate	High
3.1.4	Full Clinch Straightening Method		R,F,W	Intermediate	High
3.1.5	Full Clinch Wicking Method		R,F,W	Advanced	High

3.2 PGA and Connector Removal

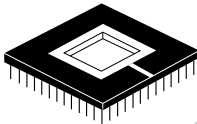
Procedure	Description		Board Type	Skill Level	Level of Conformance
3.2.1	Solder Fountain Method		R,F,W,C	Expert	High

3.3 Chip Component Removal

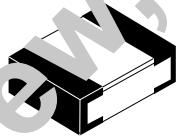
Procedure	Description		Board Type	Skill Level	Level of Conformance
3.3.1	Bifurcated tip		R,F,W,C	Intermediate	High
3.3.2	Tweezer Method		R,F,W,C	Intermediate	High
3.3.3	Including Bottom Termination Hot Air Method		R,F,W,C	Intermediate	High

3.4 Leadless Component Removal

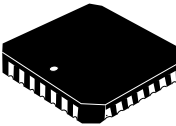
Procedure	Description		Board Type	Skill Level	Level of Conformance
3.4.1	Solder Wrap Method - Tweezer		R,F,W,C	Advanced	High
3.4.2	Flux Application Method - Tweezer		R,F,W,C	Advanced	High
3.4.3	Hot Gas (Air) Reflow Method		R,F,W,C	Advanced	High

3.5 SOT Removal

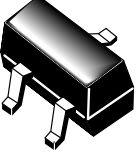
Procedure	Description		Board Type	Skill Level	Level of Conformance
3.5.1	Flux Application Method		R,F,W,C	Intermediate	High
3.5.2	Flux Application Method - Tweezer		R,F,W,C	Intermediate	High
3.5.3	Hot Air Pencil		R,F,W,C	Intermediate	High

3.6 Gull Wing Removal (two-sided)

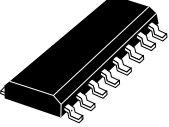
Procedure	Description		Board Type	Skill Level	Level of Conformance
3.6.1	Bridge Fill Method		R,F,W,C	Intermediate	High
3.6.2	Solder Wrap Method		R,F,W,C	Intermediate	High
3.6.3	Flux Application Method		R,F,W,C	Intermediate	High
3.6.4	Bridge Fill Method - Tweezer		R,F,W,C	Advanced	High
3.6.5	Solder Wrap Method - Tweezer		R,F,W,C	Advanced	High
3.6.6	Flux Application Method - Tweezer		R,F,W,C	Advanced	High

3.7 Gull Wing Removal (four-sided)

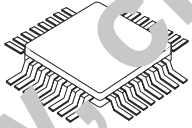
Procedure	Description		Board Type	Skill Level	Level of Conformance
3.7.1	Bridge Fill Method - Vacuum Cup		R,F,W,C	Advanced	High
3.7.1.1	Bridge Fill Method - Surface Tension		R,F,W,C	Intermediate	High
3.7.2	Solder Wrap Method - Vacuum Cup		R,F,W,C	Advanced	High
3.7.2.1	Solder Wrap Method - Surface Tension		R,F,W,C	Intermediate	High
3.7.3	Flux Application Method - Vacuum Cup		R,F,W,C	Advanced	High
3.7.3.1	Flux Application Method - Surface Tension		R,F,W,C	Intermediate	High
3.7.4	Bridge Fill Method - Tweezer		R,F,W,C	Advanced	High
3.7.5	Solder Wrap Method - Tweezer		R,F,W,C	Advanced	High
3.7.6	Flux Application Method - Tweezer		R,F,W,C	Advanced	High
3.7.7	Hot Cans (Air) Reflow Method		R,F,W,C	Advanced	High

3.8 J-Lead Removal

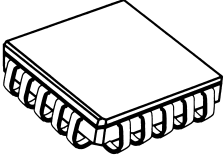
Procedure	Description		Board Type	Skill Level	Level of Conformance
3.8.1	Bridge Fill Method - Tweezer		R,F,W,C	Advanced	High
3.8.1.1	Bridge Fill Method - Surface Tension		R,F,W,C	Advanced	High
3.8.2	Solder Wrap Method - Tweezer		R,F,W,C	Advanced	High
3.8.2.1	Solder Wrap Method - Surface Tension		R,F,W,C	Advanced	High
3.8.3	Flux Application Method - Tweezer		R,F,W,C	Advanced	High
3.8.4	Flux & Tin Tip Only		R,F,W,C	Advanced	High
3.8.5	Hot Gas Reflow System		R,F,W,C	Advanced	High

3.9 BGA/CSP Removal

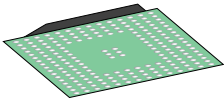
Procedure	Description		Board Type	Skill Level	Level of Conformance
3.9.1	Hot Gas Reflow System		R,F,W,C	Advanced	High
3.9.1.2	Focused IR Reflow Systems (with integral preheater)		R,F,W,C	Advanced	High
3.9.2	Vacuum Method		R,F,W,C	Advanced	Medium

3.10 PLCC Socket Removal

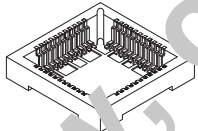
Procedure	Description		Board Type	Skill Level	Level of Conformance
3.10.1	Bridge Fill Method		R,F,W,C	Advanced	High
3.10.2	Solder Wrap Method		R,F,W,C	Advanced	High
3.10.3	Flux Application Method		R,F,W,C	Advanced	High
3.10.4	Hot Air Pencil Method		R,F,W,C	Advanced	Medium

3.11 Bottom Terminated Component Removal

Procedure	Description	Board Type	Skill Level	Level of Conformance
3.11.1	Hot Air Method	R,F,C	Expert	Medium

4 Pad/Land Preparation

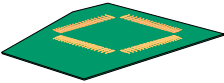
Procedure	Description		Board Type	Skill Level	Level of Conformance
4.1.1	Surface Mount Land Preparation - Individual Method		R,F,W,C	Intermediate	High
4.1.2	Surface Mount Land Preparation - Continuous Method		R,F,W,C	Intermediate	High
4.1.3	Surface Solder Removal - Braid Method		R,F,W,C	Intermediate	High
4.2.1	Pad Releveling - Using Blade Tip		R,F,W,C	Intermediate	High
4.3.1	SMT Land Tinning - Using Blade Tip		R,F,W,C	Intermediate	Medium
4.4.1	Cleaning SMT Lands - Using Blade Tip and Solder Braid		R,F,W,C	Intermediate	High

5 Installation

5.1 Through-Hole Installation

Procedure	Description	
	Install following the requirements of J-STD-001 and IPC-HDBK-001	

5.2 PGA and Connector Installation

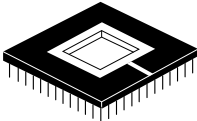
Procedure	Description		Board Type	Skill Level	Level of Conformance
5.2.1	Solder Fountain Method with PTH Prefilled		R,F,W,C	Expert	High

5.3 Chip Installation

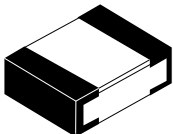
Procedure	Description		Board Type	Skill Level	Level of Conformance
5.3.1	Solder Paste Method/Hot Air Pencil		R,F,W,C	Intermediate	High
5.3.2	Point-to-Point Method		R,F,W,C	Intermediate	High

5.4 Leadless Component Installation

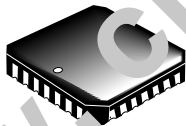
Procedure	Description		Board Type	Skill Level	Level of Conformance
5.4.1	Hot Gas (Air) Reflow Method		R,F,W,C	Advanced	High

5.5 Gull Wing Installation

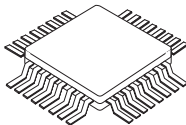
Procedure	Description		Board Type	Skill Level	Level of Conformance
5.5.1	Multi-Lead Method - Top of Lead		R,F,W,C	Advanced	High
5.5.2	Multi-Lead Method - Toe Tip		R,F,W,C	Advanced	High
5.5.3	Point-to-Point Method		R,F,W,C	Intermediate	High
5.5.4	Solder Paste Method/Hot Air Pencil		R,F,W,C	Advanced	High
5.5.5	Hook Tip w/Wire Layover		R,F,W,C	Intermediate	High
5.5.6	Blade Tip with Wire		R,F,W,C	Advanced	Medium
5.5.7	Adhesive Backed Stencil, Solder Paste Method/Hot Air		R,F,W,C	Advanced	High

5.6 J-Lead Installation

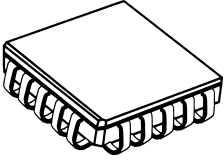
Procedure	Description		Board Type	Skill Level	Level of Conformance
5.6.1	Solder Wire Method		R,F,W,C	Advanced	High
5.6.2	Point-to-Point Method		R,F,W,C	Intermediate	High
5.6.3	Solder Paste Method/Hot Air Pencil		R,F,W,C	Advanced	High
5.6.4	Multi-Lead Method		R,F,W,C	Intermediate	High

5.7 BGA/CSP Installation

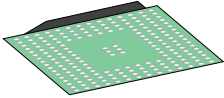
Procedure	Description		Board Type	Skill Level	Level of Conformance
5.7.1	Using Solder Wire to Prefill Lands		R,F,W,C	Advanced	High
5.7.1.2	Focused IR Reflow System (with integral preheater)		R,F,W,C	Advanced	High
5.7.2	Using Solder Paste to Prefill Lands		R,F,W,C	Advanced	High
5.7.2.1	Stay-in-Place Stencil		R,F,C	Advanced	Medium
5.7.3	BGA Reballing Procedure - Fixture Method		R,C	Advanced	High
5.7.4	BGA Reballing Procedure - Paper Carrier Method		R,C	Advanced	High
5.7.5	BGA Reballing Procedure - Polyimide Stencil Method		R,C	Advanced	High
5.7.6	Polyimide Solder Ball Stencil Carrier		R,C	Advanced	High

5.8 Bottom Terminated Device

Procedure	Description	Board Type	Skill Level	Level of Conformance
5.8.1.1	Installation Pre-bump and place	R,F,C	Expert	Medium
5.8.1.2	Installation Pre-bump and place with stencil in place stencil	R,F,C	Expert	Medium
5.8.1.3	Installation Pre-Hand soldering plus centered ground bump	R,F,C	Expert	Medium

6 Removing Shorts

Procedure	Description		Board Type	Skill Level	Level of Conformance
6.1.1	J-Leads - Draw Off Method		R,F,W,C	Intermediate	High
6.1.2	J-Leads - Respread Method		R,F,W,C	Intermediate	High
6.1.2.1	J-Leads - Braid Method		R,F,W,C	Intermediate	High
6.1.3	Gull-Wing - Draw Off Method		R,F,W,C	Intermediate	High
6.1.4	Gull-Wing - Respread Method		R,F,W,C	Intermediate	High
6.1.4.1	Gull-Wing - Braid Method		R,F,W,C	Intermediate	High

Table of Contents

PART 3 Modification and Repair

Blisters and Delamination

Procedure	Description	Illustration	Board Type	Skill Level	Level of Conformance
3.1	Delamination/Blister Repair, Injection Method		R	Advanced	High

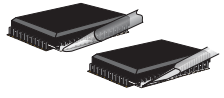
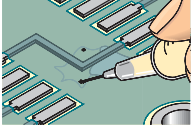
Bow & Twist

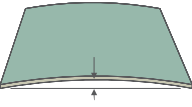
Procedure	Description	Illustration	Board Type	Skill Level	Level of Conformance
3.2	Bow and Twist Repair		R, W	Advanced	Medium

Hole Repair

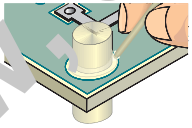
Procedure	Description	Illustration	Board Type	Skill Level	Level of Conformance
3.3.1	Hole Repair, Epoxy Method		R, W	Advanced	High
3.3.2	Hole Repair, Transplant Method		R, W	Expert	High

Key and Slot Repair

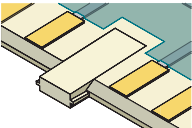
Procedure	Description	Illustration	Board Type	Skill Level	Level of Conformance
3.4.1	Key and Slot Repair, Epoxy Method		R, W	Advanced	High
3.4.2	Key and Slot Repair, Transplant Method		R, W	Expert	High



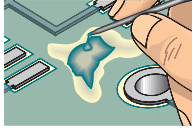
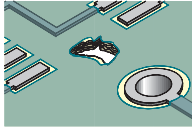
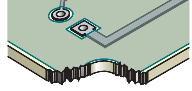

Base Material Repair

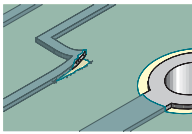
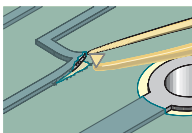
Procedure	Description	Illustration	Board Type	Skill Level	Level of Conformance
3.5.1	Base Material Repair, Epoxy Method	 A hand uses a syringe to apply a yellow epoxy resin into a hole on a green PCB. A magnifying glass is positioned over the repair area.	R, W	Advanced	High
3.5.2	Base Material Repair, Area Transplant Method	 A magnifying glass shows a hole on a green PCB. A separate piece of material is being prepared to be transplanted into the hole.	R, W	Expert	High
3.5.3	Base Material Repair, Edge Transplant Method	 A magnifying glass shows a hole on the edge of a green PCB. A separate piece of material is being prepared to be transplanted into the hole.	R, W	Expert	High

Lifted Conductors

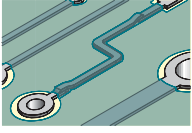
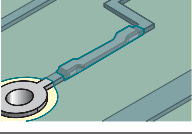
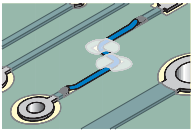
Procedure	Description	Illustration	Board Type	Skill Level	Level of Conformance
4.1.1	Lifted Conductor Repair, Epoxy Seal Method	 A magnifying glass shows a lifted conductor on a green PCB. A yellow epoxy resin is being applied to seal the gap.	R, F	Intermediate	Medium
4.1.2	Lifted Conductor Repair, Film Adhesive Method	 A magnifying glass shows a lifted conductor on a green PCB. A yellow film adhesive is being applied to the gap.	R, F	Intermediate	High

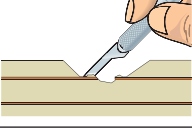
Conductor Repair

Procedure	Description	Illustration	Board Type	Skill Level	Level of Conformance
4.2.1	Conductor Repair, Foil Jumper, Epoxy Method		R, F, C	Advanced	Medium
4.2.2	Conductor Repair, Foil Jumper, Film Adhesive Method		R, F, C	Advanced	High
4.2.3	Conductor Repair, Welding Method		R, F, C	Advanced	High
4.2.4	Conductor Repair, Surface Wire Method		R, F, C	Intermediate	Medium
4.2.5	Conductor Repair, Through Board Wire Method		R	Advanced	Medium
4.2.6	Conductor Repair/Modification, Conductive Ink Method		R, F, C	Expert	Medium
4.2.7	Conductor Repair, Inner Layer Method		R, F	Expert	High

Conductor Cut

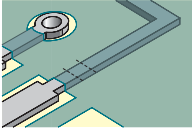
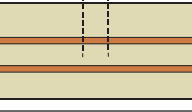
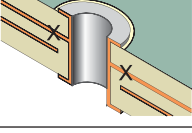
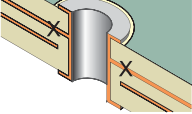
Procedure	Description	Illustration	Board Type	Skill Level	Level of Conformance
4.3.1	Conductor Cut, Surface Conductors		R, F	Advanced	High
4.3.2	Conductor Cut, Inner Layer Conductors		R, F	Advanced	High
4.3.3	Deleting Inner Layer Connection at a Plated Hole, Drill Through Method		R, F	Advanced	High
4.3.4	Deleting Inner Layer Connection at a Plated Hole, Spoke Cut Method		R, F	Advanced	High

Lifted Land Repair

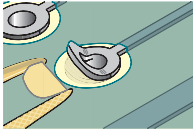
Procedure	Description	Illustration	Board Type	Skill Level	Level of Conformance
4.4.1	Lifted Land Repair, Epoxy Method	 A top-down view of a PCB pad with a lifted land. A syringe is shown applying epoxy to the pad.	R, F	Advanced	Medium
4.4.2	Lifted Land Repair, Film Adhesive Method	 A top-down view of a PCB pad with a lifted land. A syringe is shown applying adhesive to the pad, and a yellow film is being applied over it.	R, F	Advanced	Medium

Land Repair

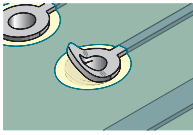
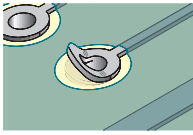
Procedure	Description	Illustration	Board Type	Skill Level	Level of Conformance
4.5.1	Land Repair, Epoxy Method	 A top-down view of a PCB pad with a land repair. A syringe is shown applying epoxy to the pad.	R, F	Advanced	Medium
4.5.2	Land Repair, Film Adhesive Method	 A top-down view of a PCB pad with a land repair. A syringe is shown applying adhesive to the pad, and a yellow film is being applied over it.	R, F	Advanced	High

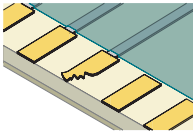
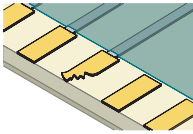
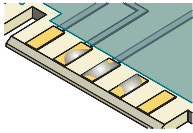

Edge Contact Repair

Procedure	Description	Illustration	Board Type	Skill Level	Level of Conformance
4.6.1	Edge Contact Repair, Epoxy Method	 A cross-sectional view of a PCB edge with a damaged contact. A syringe is shown applying epoxy to the edge.	R, F, W, C	Advanced	Medium
4.6.2	Edge Contact Repair, Film Adhesive Method	 A cross-sectional view of a PCB edge with a damaged contact. A syringe is shown applying adhesive to the edge, and a yellow film is being applied over it.	R, F, W, C	Advanced	High
4.6.3	Edge Contact Repair, Plating Method	 A cross-sectional view of a PCB edge with a damaged contact. A syringe is shown applying a plating solution to the edge.	R, F, W, C	Advanced	High

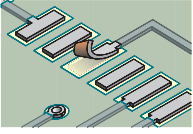
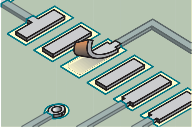
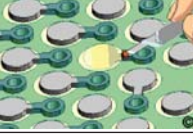

Surface Mount Pad Repair

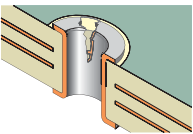
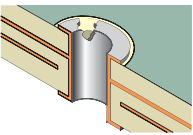
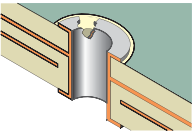
Procedure	Description	Illustration	Board Type	Skill Level	Level of Conformance
4.7.1	Surface Mount Pad Repair, Epoxy Method		R, F, C	Advanced	Medium
4.7.2	Surface Mount Pad Repair, Film Adhesive Method		R, F, C	Advanced	High
4.7.3	Surface Mount, BGA Pad Repair, Film Adhesive Method		R, F, C	Advanced	High
4.7.4	Surface Mount, BGA Land with Integral Via Repair Film Adhesive Method		R,F	Expert	Medium
4.7.4.1	Surface Mount Pad with Integral Via Repair Film Adhesive Method - No Conductor Bend		R,F	Expert	Medium
4.7.5	Surface Mount, BGA Land with Integral Via Repair Circuit Extension Film Adhesive Method		R,F,C	Expert	High

Plated Hole Repair

Procedure	Description	Illustration	Board Type	Skill Level	Level of Conformance
5.1	Plated Hole Repair, No Inner Layer Connection		R, F, W	Intermediate	High
5.2	Plated Hole Repair, Double Wall Method		R, F, W	Advanced	Medium
5.3	Plated Hole Repair, Inner Layer Connection		R	Expert	Medium
5.4	Plated Hole Repair, No Inner Layer Connection, Clinched Jumper Wire Method		R,F,W	Intermediate	Medium

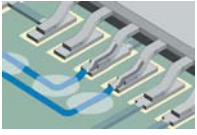
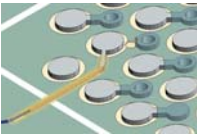
Jumpers

Procedure	Description	Illustration	Board Type	Skill Level	Level of Conformance
6.1	Jumper Wires		R, F, W, C	Intermediate	N/A
6.2.1	Jumper Wires, BGA Components, Foil Jumper Method		R, F	Expert	Medium
6.2.2	Jumper Wires, BGA Components, Through Board Method		R, F	Expert	High

Component Additions

Procedure	Description	Illustration	Board Type	Skill Level	Level of Conformance
6.3	Component Modifications and Additions		R, F, W, C	Advanced	N/A

Flexible Conductor Repair

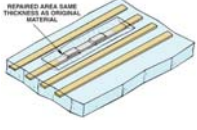
Procedure	Description	Illustration	Board Type	Skill Level	Level of Conformance
7.1.1	Flexible Conductor Repair		F	Expert	Medium

8 Wires**8.1 Splicing**

Procedure	Description		Board Type	Skill Level	Level of Conformance
8.1.1	Mesh Splice		N/A	Intermediate	Low
8.1.2	Wrap Splice		N/A	Intermediate	Low
8.1.3	Hook Splice		N/A	Intermediate	Low
8.1.4	Lap Splice		N/A	Intermediate	Low

General Information and Common Procedures

1.1 Scope This document covers procedures for repairing and reworking printed board assemblies. It is an aggregate of information collected, integrated and assembled by the Repairability Subcommittee (7-34) of the Product Assurance Committee of the IPC. This revision includes expanded coverage for lead free processes, and additional inspection guidelines for operations such as repair that may not have other published criteria.

This document does not limit the maximum number of rework, modification or repair actions to a Printed Circuit Assembly.

1.2 Purpose This document prescribes the procedural requirements, tools, materials and methods to be used in the rework, repair, modification, overhaul or restoration of electronic products. Although this document is based in large part on the Product Class definitions used in IPC documents such as J-STD-001 or IPC-A-610, this document should be considered applicable to any type of electronic equipment. When invoked by contract as the controlling document for the rework, repair, modification, overhaul or restoration of products, the requirements flow-down apply.

IPC has identified the most common equipment and process in order to perform a specific repair or rework. It is possible that alternate equipment and processes can be used to make the same repair/rework. If alternate equipment or processes are used, it is up to the user to ensure the equipment/processes do not damage the assembly and meet the intent of Section 1.5.1.1 (Levels of Conformance) for the alternate equipment/processes utilized.

1.2.1 Definition of Requirements This document is intended to be used as a guide and there are no specific requirements or criteria unless separately and specifically called out in a user's contractual or other documentation. When statements such as "must," "should" or "need to be" are used, they are stressing an important point. If these strong recommendations are not followed, the end result may not be satisfactory and additional damage could be caused.

Arrows in the rework procedures are either up or down describing the type of rework procedure being conducted. An up arrow means removal and a down arrow means installing.

1.3 Background Today's electronic assemblies are more complex and smaller than ever before. Despite this, they can be successfully reworked, repaired or modified if the

proper techniques are followed. This manual is designed to help users rework, repair and/or modify electronic assemblies with minimum impact on end use functionality or reliability. The procedures in this document have been obtained from assemblers, printed board manufacturers and users who recognize the need for documenting commonly used rework, repair and modification techniques. These techniques have, in general, been proven to be acceptable for the class of product indicated through testing and extended field functionality. Procedures contained herein were submitted for inclusion by commercial and military organizations too numerous to list individually. The Repairability Subcommittee has, where appropriate, revised procedures to reflect improvements.

1.4 Terms and Definitions The following definitions apply to the use of this document.

PCA – Printed Circuit Assembly

Rework – the act of reprocessing noncomplying articles, through the use of original or equivalent processing, in a manner that assures full compliance of the article with applicable drawings or specifications.

Modification – the revision of the functional capability of a product in order to satisfy new acceptance criteria. Modifications are usually required to incorporate design changes which can be controlled by drawings, change orders, etc. Modifications should only be performed when specifically authorized and described in detail on controlled documentation.

Repair – the act of restoring the functional capability of a defective article in a manner that does not assure compliance of the article with applicable drawings or specifications.

Tack Solder – A solder connection commonly used to temporarily align and retain a multilead component in place on a PCB during the soldering of the other leads. A tack solder connection typically requires additional reflow to form the final solder connection.

1.4.1 Class of Product The user of the product is responsible for identifying the Class of Product. The procedure selected for action to be taken (rework, repair, modification, ...) must be consistent with the Class identified by the user. The three Classes of Product are:

Class 1 – General Electronic Products

Includes products suitable for applications where the major requirement is the function of the completed assembly.

Class 2 – Dedicated Service Electronic Products

Includes products where continued performance and extended life is required, and for which uninterrupted service is desired but not critical. Typically, the end use environment would not cause failures.

Class 3 – High Performance/Harsh Environment Electronic Products

Includes products where continued high performance or performance-on-demand is critical, equipment downtime cannot be tolerated, end-use environment may be uncommonly harsh, and the equipment must function when required, such as life support and other critical systems.

1.4.2 Board Types There are a variety of printed board types that the procedures in this document apply to. When selecting the appropriate rework, repair or modification procedure, the printed board type being worked should be considered. Select a procedure that applies to the printed board type as listed on the procedure. Printed board types include the following:

- R. *Rigid Printed Boards and Assemblies* – A printed board or assembly using rigid base materials only. These may be single-sided, double-sided or multilayered, and may be constructed from base laminate material that spans all approved commercial grades of laminate and includes glass fabric reinforced epoxy and polyimide resin laminates.
- F. *Flexible Printed Boards and Assemblies* – A printed board or assembly using flexible or a combination of rigid and flexible materials, which may utilize electrically nonfunctional stiffeners and/or cover layers. These may be single-sided, double-sided or multilayered.
- W. *Discrete Wiring Boards and Assemblies* – A printed board or assembly using a discrete wiring technique to obtain electrical interconnections.
- C. *Ceramic Boards and Assemblies* – A printed board or assembly using ceramic as the base material with interconnections separated by dielectric. The board layers are usually formed by alternate printing or depositing of interconnections and dielectric. The assemblies are either surface mount or die attach. Usually multilayered, these may be single-sided or double-sided.

1.4.3 Skill Level To assist in determining the skill level needed for each procedure, a Skill Level indicator is included in each process. The Skill Level recommended should be used as a guide only. Skill levels will vary widely from technician to technician and from company to company. These recommendations come from industry experience and are not necessarily backed up with substantive testing. Skills are separated into three categories.

- I. *Intermediate* – Technician with skills in basic soldering and component rework but inexperienced in general repair/rework procedures.
- A. *Advanced* – Technician with soldering and component rework skills and exposure to most repair/rework procedures but lacking extensive experience.
- E. *Expert* – Technician with advanced soldering and component rework skills and extensive experience in most repair/rework procedures.

1.5 Applicability, Controls and Acceptability Although the terms rework, repair and modification may seem very similar, applicability of such procedures may not be the same due to conditions and objectives involved. Procedures and guidelines of this document may be used during manufacturing of products or to products that have been delivered and/or failed in use.

In general, rework, repair or modification controls during manufacturing are different from the controls applied to products that fail after being placed in service and should be considered when dispositioning hardware.

When a defect or functional problem is discovered during the assembly process, a decision has to be made whether to rework or repair the product, use it as is, or discard it. Other than rework, this decision is typically the responsibility of a Material Review Board (MRB) as discussed in various assembly standards.

When a product fails after it has been placed in service, the term “repair” is commonly applied to actions taken in the service environment that restore operational use. Unlike the manufacturing process, there is no Material Review Board to disposition the failed assembly. How that decision is made is beyond the scope of this document.

When a disposition decision has been made that involves removing and replacing a failed component, the rework procedures in Part 2 - 7711 would be applicable. If a repair or modification is needed, the procedures in Part 3 - 7721 would be applicable.

1.5.1 Level of Conformance The Level of Conformance ratings provide the means for selecting a procedure with an appropriate level of conformance to the original electrical, mechanical, physical, environmental and visual product requirements. Each procedure lists a Level of Conformance that the product should attain when successfully completed. The Level of Conformance rating for each procedure is based on the skill of the technician, and is based on long term industry experience and are not necessarily backed up with testing data.