



IPC-2223E

Sectional Design Standard for Flexible/Rigid-Flexible Printed Boards

Developed by the Flexible Circuits Design Subcommittee (D-11) of the
Flexible Circuits Committee (D-10) of IPC

Supersedes:

IPC-2223D - September 2016
IPC-2223C - November 2011
IPC-2223B - May 2008
IPC-2223A - June 2004
IPC-2223 - November 1998
IPC-D-249 - January 1987

Users of this publication are encouraged to participate in the
development of future revisions.

Contact:

IPC

Table of Contents

1	SCOPE	1	5	MECHANICAL AND PHYSICAL PROPERTIES	11
1.1	Purpose	1	5.1	Fabrication Requirements	11
1.2	Classification of Products	1	5.1.1	Bare Printed Board Fabrication	11
1.2.1	Printed Board Type	1	5.1.2	Roll to Roll Fabrication	11
1.2.2	Installation Uses	4	5.2	Product/Printed Board Configuration	12
1.3	Revision Level Changes	4	5.2.1	Circuit Profile (Outline)	12
2	APPLICABLE DOCUMENTS	4	5.2.2	Rigid Area Considerations	13
2.1	IPC	4	5.2.3	Flexible Areas	13
2.2	Joint Industry Standards	4	5.2.4	Preforming Bend	16
3	GENERAL REQUIREMENTS	5	5.2.5	Differential Lengths	17
3.1	Design Modeling	5	5.2.6	Shielding	21
3.2	Design Layout	5	5.2.7	Ground/Power Plane	21
3.2.1	Mechanical Layout Efficiency (Consider Final Panelization)	5	5.2.8	Stiffeners and Heat Sinks	21
3.2.2	Fabrication Drawing Recommendations	5	5.2.9	Strain Relief Pallet Guidelines for Flexible and Rigid Printed Boards	21
3.3	Schematic	5	5.3	Assembly Requirements	22
3.4	Test Requirement Considerations	6	5.3.1	Mechanical Considerations	22
3.4.1	Environmental	6	5.3.2	Area Sub-Pallets for Flexible and Rigid Printed Boards	22
3.4.2	Mechanical/Flexural	6	5.3.3	Single Part Sub-Pallets	22
4	MATERIALS	6	5.3.4	Non-Palletized Flexible and Rigid-Flex Printed Boards	22
4.1	Material Selection	6	5.3.5	Moisture	23
4.1.1	Material Options	7	5.3.6	Infrared Preheats and Reflow	23
4.2	Dielectric Materials (Including Prepreg and Adhesives)	7	5.3.7	Adhesive T _g	23
4.2.1	Preimpregnated Bonding Material (Prepreg)	7	5.4	Dimensioning	23
4.2.2	Adhesives (Liquid)	7	5.4.1	Datum Features	23
4.2.3	Flexible Adhesive Bonding Film (Cast Adhesive or Bondply)	7	6	ELECTRICAL PROPERTIES	23
4.2.4	Conductive Anisotropic Adhesives	7	6.1	Electrical Considerations	23
4.2.5	Cover Materials	8	6.2	Impedance and Capacitance Control	24
4.3	Conductive Materials (Surface Finishes)	9	6.2.1	Impedance Modeling Software	24
4.3.1	Electrolytic Copper Plating	9	6.2.2	Material Thickness and Stack Up	24
4.3.2	Nickel Plating	10	6.2.3	Conductor Pitch	24
4.3.3	Tin-Lead Plating	10	6.2.4	Narrow Conductors	24
4.3.4	Solder Coating	10	6.2.5	Differential Impedance	25
4.3.5	Other Metallic Coatings	11	6.2.6	Unbonded Flexible Impedance Controlled Layers (“Loose-leaf layers”)	25
4.3.6	Electronic Component Materials (Buried Resistors and Capacitors)	11	6.2.7	Modifications to Shield Layers	26
4.3.7	Conductive Coatings for Shielding	11	6.2.8	Dielectric Constant Changes Over Frequency	27
4.4	Organic Protective Coatings	11	7	THERMAL MANAGEMENT	27
4.4.1	Solder Mask	11	8	COMPONENT AND ASSEMBLY ISSUES	27
4.4.2	Conformal Coating	11	8.1	General Placement Requirements	27
4.5	Marking and Legend	11	8.2	Standard Surface Mount Requirements	27

8.3 Lands for Surface Mounting 27

8.4 Constraints on Mounting to Flexible Sections .. 27

8.5 Interfacial Connections 27

8.6 Offset Lands 27

9 HOLES/INTERCONNECTIONS 28

9.1 General Requirements for Lands with Holes 28

9.1.1 Land Requirements 28

9.1.2 Annular Ring Requirements 28

9.1.3 Eyelet or Standoff Land Area Considerations ... 28

9.1.4 Land Size for Non-Plated Component Holes ... 28

9.1.5 Land Size for Plated-Through Component Holes 28

9.1.6 Thermal Relief in Conductor Planes 28

9.1.7 Surface Mount Components 28

9.1.8 Nonfunctional Lands 28

9.1.9 Land-to-Conductor Transition 29

9.1.10 Unsupported Edge Conductors/Fingers 29

9.2 Holes 36

9.2.1 Unsupported (Non-Plated) Component Holes ... 36

9.2.2 Plated Component Holes 36

9.2.3 Copper Filled Vias 36

9.2.4 Back-drilled Holes 36

9.3 Coverlay Access Openings 36

9.3.1 Coverlay Access, Unsupported Lands 36

9.3.2 Coverlay Access, Holes 37

9.3.3 Coverlay Access Spacing 38

9.3.4 Land Access/Exposed Lands 38

9.3.5 Type 1 Land Access, Opposite Sides 38

10 CONDUCTORS 38

10.1 Conductor Characteristics 38

10.1.1 Conductor Routing 38

10.1.2 Conductor Edge Spacing 39

10.2 Land Characteristics 39

10.3 Large Conductive Areas 39

11 DOCUMENTATION 39

12 QUALITY ASSURANCE 39

APPENDIX A Design Tutorial 40

Figure 1-4 Type 2 Double-Sided Flexible Printed Board – Adhesiveless Substrate Construction 2

Figure 1-5 Type 3 Multilayer Flexible Printed Board – Adhesive Substrate Construction 2

Figure 1-6 Type 3 Multilayer Flexible Printed Board – Adhesiveless Substrate Construction 2

Figure 1-7 Type 4 Rigid-Flex Printed Board – Adhesive Substrate Construction 3

Figure 1-8 Type 4 Rigid-Flex Printed Board – Adhesiveless Substrate Construction 3

Figure 1-9 Type 5 Flexible or Rigid-Flex Printed Board without PTHs – Adhesive Substrate Construction 3

Figure 1-10 Type 5 Flexible or Rigid-Flex Printed Board without PTHs – Adhesiveless Substrate Construction 3

Figure 3-1 Dimensional Modeling 5

Figure 3-2 Final Panelization 5

Figure 4-1 Flexible Cross-Sectional Construction Examples 6

Figure 4-2 Unbonded Flex Cross-Sectional Construction of Rigid Flex 6

Figure 4-3 Plating for Adhesiveless Substrate Applications 10

Figure 4-4 Selective Plating for Adhesive Substrate Applications 10

Figure 5-1 Circuit Nested On a Panel 12

Figure 5-2 Special Flexible Printed Board Features 12

Figure 5-3 Cutout with a Drilled Hole 12

Figure 5-4 Reinforcement Patch for Flex Area 12

Figure 5-5 Slits and Slots 13

Figure 5-6 Spacing of PTH from Rigid to Flex Interface 13

Figure 5-7 Reduced Bend Radii 14

Figure 5-8 Conductors in Bend Areas 14

Figure 5-9 Bend/Crease Areas Center Lines 15

Figure 5-10 Neutral Axis Ideal Construction 15

Figure 5-11 Definition of Bend Ratio 16

Figure 5-12 Irregular Folds 17

Figure 5-13 Differential Printed Board Lengths 18

Figure 5-14 Differential Printed Board Lengths, Rigid-Flex 18

Figure 5-15 Bookbinder 20

Figure 5-16 Staggered Flexible Layer Bands 20

Figure 5-17 Staggered Flexible Layer Bands 20

Figure 5-18 Typical Example of Copper Removal for Flexible Shielding 21

Figure 5-19 Stiffener Thickness Preferred in Order to Apply Strain Relief Fillet 21

Figure 5-20 Strain Relief 22

Figure 5-21 Rigid Rails for Single Part Sub-Pallets 22

Figure 5-22 Establishing Datums 23

Figure 6-1 Adjustment to Dielectric Thickness between Rigid and Flexible Regions 24

Figures

Figure 1-1 Type 1 Single-Sided Flexible Printed Board – Adhesive Substrate Construction 1

Figure 1-2 Type 1 Single-Sided Flexible Printed Board – Adhesiveless Substrate Construction 1

Figure 1-3 Type 2 Double-Sided Flexible Printed Board – Adhesive Substrate Construction 2

Figure 6-2 Conductor Pitch for Differential Pairs 25

Figure 6-3 TDR Waveform for Type 2 Flexible Printed Board 25

Figure 6-4 Buckling of Unbonded Flexible Layers 26

Figure 6-5 Cross Hatching 26

Figure 9-1 Conductor to Land Transitions 28

Figure 9-2 Sculptured, Straight, Tapered Fingers 30

Figure 9-3 Sculptured, Formed for Surface Mount 30

Figure 9-4 Sculptured, Formed for Through-Hole 30

Figure 9-5 Straight Fingers for Lap Soldering to Printed Board 30

Figure 9-6 Adhesive Squeeze Out Where Fingers Exit Insulation 33

Figure 9-7 Laser Ablated Window 33

Figure 9-8 Broken Fingers Resulting from Poor Handling 33

Figure 9-9 Fingers Connected with a Foil Buss Bar 34

Figure 9-10 Insulator Buss Bar with Notched Fingers 34

Figure 9-11 Fingers Attached to a Support Bar 34

Figure 9-12 Staggered Base/Coverlay Edges Used to Reduce Stress Points 34

Figure 9-13 Sculptured Flex Showing the Foil Thickness Transition 35

Figure 9-14 Fingers Brazed to Circuit Lands 35

Figure 9-15 Bonding of Unsupported Fingers to Printed Board with Reinforcement 35

Figure 9-16 Coverlay Access Openings and Exposed Unsupported Lands 37

Figure 9-17 Coverlay Access Opening for Unsupported Lands 37

Figure 9-18 Coverlay Access Openings and Exposed Supported Lands 38

Figure 10-1 Conductor Routing, Rigid-Flex Transition 38

Figure A-1 Single Row ZIF Style Printed Board Contact Area 41

Figure A-2 Dual Row ZIF Style Printed Board Contact Area 41

Tables

Table 4-1 Characteristics of Typical Flexible Dielectrics 8

Table 4-2 Minimum Average Copper Thickness, mm [in] ... 9

Table 9-1 Minimum Standard Fabrication Allowance for Interconnect Land, mm [in] 28

Table 9-2 Nonfunctional Land Considerations 29

Table 9-3 Typical Foil Options for Designing for Flex Circuits with Unsupported Fingers 31

Table 9-4 Typical Foil Options for Designing for Flex Circuits with Unsupported Fingers (continued) 32

Table 9-4 Common Brazed Finger Options 35

Currently in preview, click for full version

Sectional Design Standard for Flexible/ Rigid-Flexible Printed Boards

1 SCOPE

This standard establishes the specific requirements for the design of flexible and rigid-flexible printed board applications and its forms of component mounting and interconnecting structures. The flexible materials used in the structures are comprised of insulating films, reinforced and/or non-reinforced, dielectric in combination with metallic materials. These interconnecting boards may contain single, double, multilayer, or multiple conductive layers and can be comprised wholly of flexible or a combination of both flex and rigid.

1.1 Purpose The requirements contained herein are intended to establish specific design details that shall be used in conjunction with IPC-2221 and may also be used in conjunction with IPC-2222 for the rigid sections of rigid-flex circuits.

1.2 Classification of Products Classification type and use of products shall be in accordance with IPC-2221 and as stated in 1.2.1 and 1.2.2.

1.2.1 Printed Board Type This standard provides design information for different flexible and rigid-flex printed board types. Printed board types are classified as:

Type 1 Single-sided flexible printed board containing one conductive layer, with or without stiffener, and constructed using an adhesive or adhesiveless substrate (see Figure 1-1 and Figure 1-2).

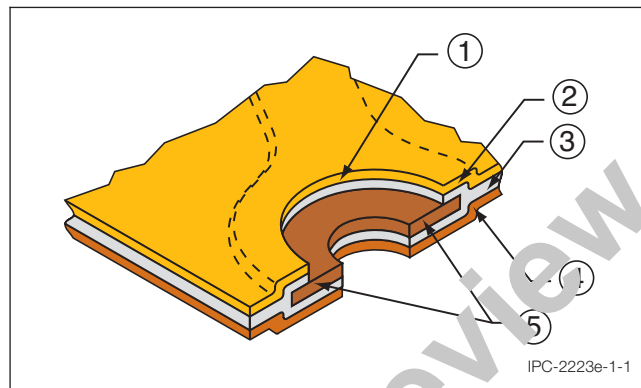

Figure 1-1 Type 1 Single-Sided Flexible Printed Board – Adhesive Substrate Construction

- Note 1:** Access Hole.
- Note 2:** Coverlay.
- Note 3:** Adhesive.
- Note 4:** Substrate.
- Note 5:** Copper Pad.

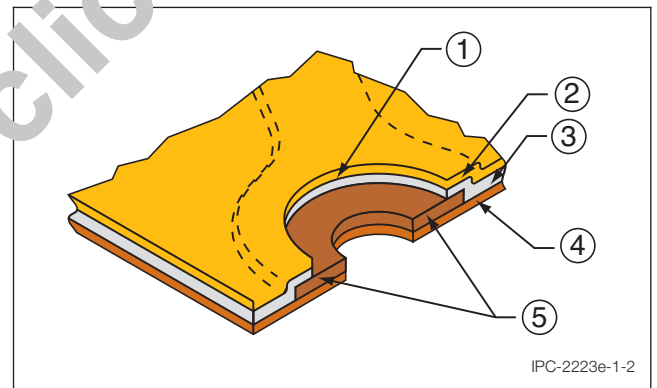

Figure 1-2 Type 1 Single-Sided Flexible Printed Board – Adhesiveless Substrate Construction

- Note 1:** Access Hole.
- Note 2:** Coverlay.
- Note 3:** Adhesive.
- Note 4:** Adhesiveless Substrate.
- Note 5:** Copper Pad.