

INTERNATIONAL STANDARD

NORME INTERNATIONALE



Secondary cells and batteries containing alkaline or other non-acid electrolytes – Safety requirements for secondary lithium cells and batteries for use in electrical energy storage systems

Accumulateurs alcalins et autres accumulateurs à électrolyte non acide – Exigences de sécurité pour les accumulateurs au lithium pour utilisation dans des systèmes de stockage d'énergie électrique



THIS PUBLICATION IS COPYRIGHT PROTECTED

Copyright © 2020 IEC, Geneva, Switzerland

All rights reserved. Unless otherwise specified, no part of this publication may be reproduced or utilized in any form or by any means, electronic or mechanical, including photocopying and microfilm, without permission in writing from either IEC or IEC's member National Committee in the country of the requester. If you have any questions about IEC copyright or have an enquiry about obtaining additional rights to this publication, please contact the address below or your local IEC member National Committee for further information.

Droits de reproduction réservés. Sauf indication contraire, aucune partie de cette publication ne peut être reproduite ni utilisée sous quelque forme que ce soit et par aucun procédé, électronique ou mécanique, y compris la photocopie et les microfilms, sans l'accord écrit de l'IEC ou du Comité national de l'IEC du pays du demandeur. Si vous avez des questions sur le copyright de l'IEC ou si vous désirez obtenir des droits supplémentaires sur cette publication, utilisez les coordonnées ci-après ou contactez le Comité national de l'IEC de votre pays de résidence.

IEC Central Office
3, rue de Varembe
CH-1211 Geneva 20
Switzerland

Tel.: +41 22 919 02 11
info@iec.ch
www.iec.ch

About the IEC

The International Electrotechnical Commission (IEC) is the leading global organization that prepares and publishes International Standards for all electrical, electronic and related technologies.

About IEC publications

The technical content of IEC publications is kept under constant review by the IEC. Please make sure that you have the latest edition, a corrigendum or an amendment might have been published.

IEC publications search - webstore.iec.ch/advsearchform

The advanced search enables to find IEC publications by a variety of criteria (reference number, text, technical committee,...). It also gives information on projects, replaced and withdrawn publications.

IEC Just Published - webstore.iec.ch/justpublished

Stay up to date on all new IEC publications. Just Published details all new publications released. Available online and once a month by email.

IEC Customer Service Centre - webstore.iec.ch/csc

If you wish to give us your feedback on this publication or for further assistance, please contact the Customer Service Centre: sales@iec.ch.

Electropedia - www.electropedia.org

The world's leading online dictionary on electrotechnology, containing more than 22 000 terminological entries in English and French, with equivalent terms in 16 additional languages. Also known as the International Electrotechnical Vocabulary (IEV) online.

IEC Glossary - std.iec.ch/glossary

67 000 electrotechnical terminology entries in English and French extracted from the Terms and Definitions clause of IEC publications issued since 2002. Some entries have been collected from earlier publications of IEC TC 37, 77, 86 and CISPR.

A propos de l'IEC

La Commission Electrotechnique Internationale (IEC) est la première organisation mondiale qui élabore et publie des Normes internationales pour tout ce qui trait à l'électricité, à l'électronique et aux technologies apparentées.

A propos des publications IEC

Le contenu technique des publications IEC est constamment revu. Veuillez vous assurer que vous possédez l'édition la plus récente, un corrigendum ou amendement peut avoir été publié.

Recherche de publications IEC -

webstore.iec.ch/advsearchform

La recherche avancée permet de trouver des publications IEC en utilisant différents critères (numéro de référence, texte, comité d'études,...). Elle donne aussi des informations sur les projets et les publications remplacées ou retirées.

IEC Just Published - webstore.iec.ch/justpublished

Restez informé sur les nouvelles publications IEC. Just Published détaille les nouvelles publications parues. Disponible en ligne et une fois par mois par email.

Service Clients - webstore.iec.ch/csc

Si vous désirez nous donner des commentaires sur cette publication ou si vous avez des questions contactez-nous: sales@iec.ch.

Electropedia - www.electropedia.org

Le premier dictionnaire d'électrotechnologie en ligne au monde, avec plus de 22 000 articles terminologiques en anglais et en français, ainsi que les termes équivalents dans 16 langues additionnelles. Egalement appelé Vocabulaire Electrotechnique International (IEV) en ligne.

Glossaire IEC - std.iec.ch/glossary

67 000 entrées terminologiques électrotechniques, en anglais et en français, extraites des articles Termes et Définitions des publications IEC parues depuis 2002. Plus certaines entrées antérieures extraites des publications des CE 37, 77, 86 et CISPR de l'IEC.

INTERNATIONAL STANDARD

NORME INTERNATIONALE



Secondary cells and batteries containing alkaline or other non-acid electrolytes – Safety requirements for secondary lithium cells and batteries for use in electrical energy storage systems

Accumulateurs alcalins et autres accumulateurs à électrolyte non acide – Exigences de sécurité pour les accumulateurs au lithium pour utilisation dans des systèmes de stockage d'énergie électrique

INTERNATIONAL
ELECTROTECHNICAL
COMMISSION

COMMISSION
ELECTROTECHNIQUE
INTERNATIONALE

ICS 29.220.30

ISBN 978-2-8322-7862-8

**Warning! Make sure that you obtained this publication from an authorized distributor.
Attention! Veuillez vous assurer que vous avez obtenu cette publication via un distributeur agréé.**

CONTENTS

FOREWORD.....	3
INTRODUCTION.....	5
1 Scope.....	6
2 Normative references	7
3 Terms and definitions	7
4 Parameter measurement tolerances	9
5 General safety considerations	10
5.1 General.....	10
5.2 Insulation and wiring.....	10
5.3 The peak voltage of charging.....	11
6 Type test conditions	11
6.1 General.....	11
6.2 Test items.....	11
7 Specific requirements and tests.....	12
7.1 Basic requirement.....	12
7.2 Resistance to abnormal heat.....	12
7.3 Casing material of a battery system that can be transported for installation or maintenance.....	12
7.4 Electric insulation check during transport and installation.....	12
7.5 Charging procedures for test purposes	13
7.6 Protection against short circuit during transport and installation.....	13
7.7 Protection for reverse connection.....	13
7.8 Overdischarge control of voltage (battery system).....	14
7.9 Drop test.....	14
7.9.1 General	14
7.9.2 Whole drop test.....	15
7.9.3 Edge and corner drop test	15
8 Information for Safety.....	16
9 Marking and designation.....	16
Annex A (informative) Wiring, connections and supply	17
Bibliography.....	18
Figure 1 – IEC 62019 as umbrella standard to various industrial applications.....	5
Figure 2 – Scope of IEC 63056	6
Figure 3 – Impact location.....	15
Figure 4 – Configuration for the shortest edge drop test.....	16
Figure 5 – Configuration for the corner drop test.....	16
Table 1 – Type test.....	12
Table 2 – Drop test method and condition	14
Table A.1 – IEC 60950-1:2005 subclauses addressing wiring, connections and supply	17
Table A.2 – Wiring, connections and supply, as addressed in IEC 62368-1	17

INTERNATIONAL ELECTROTECHNICAL COMMISSION

SECONDARY CELLS AND BATTERIES CONTAINING ALKALINE OR OTHER NON-ACID ELECTROLYTES – SAFETY REQUIREMENTS FOR SECONDARY LITHIUM CELLS AND BATTERIES FOR USE IN ELECTRICAL ENERGY STORAGE SYSTEMS

FOREWORD

- 1) The International Electrotechnical Commission (IEC) is a worldwide organization for standardization comprising all national electrotechnical committees (IEC National Committees). The object of IEC is to promote international co-operation on all questions concerning standardization in the electrical and electronic fields. To this end and in addition to other activities, IEC publishes International Standards, Technical Specifications, Technical Reports, Publicly Available Specifications (PAS) and Guides (hereafter referred to as "IEC Publication(s)"). Their preparation is entrusted to technical committees; any IEC National Committee interested in the subject dealt with may participate in this preparatory work. International, governmental and non-governmental organizations liaising with the IEC also participate in this preparation. IEC collaborates closely with the International Organization for Standardization (ISO) in accordance with conditions determined by agreement between the two organizations.
- 2) The formal decisions or agreements of IEC on technical matters express, as nearly as possible, an international consensus of opinion on the relevant subjects since each technical committee has representation from all interested IEC National Committees.
- 3) IEC Publications have the form of recommendations for international use, and are accepted by IEC National Committees in that sense. While all reasonable efforts are made to ensure that the technical content of IEC Publications is accurate, IEC cannot be held responsible for the way in which they are used or for any misinterpretation by any end user.
- 4) In order to promote international uniformity, IEC National Committees undertake to apply IEC Publications transparently to the maximum extent possible in their national and regional publications. Any divergence between any IEC Publication and the corresponding national or regional publication shall be clearly indicated in the latter.
- 5) IEC itself does not provide any attestation of conformity. Independent certification bodies provide conformity assessment services and, in some areas, accept to IEC marks of conformity. IEC is not responsible for any services carried out by independent certification bodies.
- 6) All users should ensure that they have the latest edition of this publication.
- 7) No liability shall attach to IEC or its directors, employees, servants or agents including individual experts and members of its technical committees and IEC National Committees for any personal injury, property damage or other damage of any nature whatsoever, whether direct or indirect, or for costs (including legal fees) and expenses arising out of the publication, use of, or reliance upon, this IEC Publication or any other IEC Publications.
- 8) Attention is drawn to the normative references cited in this publication. Use of the referenced publications is indispensable for the correct application of this publication.
- 9) Attention is drawn to the possibility that some of the elements of this IEC Publication may be the subject of patent rights. IEC shall not be held responsible for identifying any or all such patent rights.

International Standard IEC 63056 has been prepared by subcommittee 21A: Secondary cells and batteries containing alkaline or other non-acid electrolytes, of IEC technical committee 21: Secondary cells and batteries.

The text of this International Standard is based on the following documents:

FDIS	Report on voting
21A/718/FDIS	21A/723/RVD

Full information on the voting for the approval of this International Standard can be found in the report on voting indicated in the above table.

This document has been drafted in accordance with the ISO/IEC Directives, Part 2.

The committee has decided that the contents of this document will remain unchanged until the stability date indicated on the IEC website under "<http://webstore.iec.ch>" in the data related to the specific document. At this date, the document will be

- reconfirmed,
- withdrawn,
- replaced by a revised edition, or
- amended.

IMPORTANT – The 'colour inside' logo on the cover page of this publication indicates that it contains colours which are considered to be useful for the correct understanding of its contents. Users should therefore print this document using a colour printer.

INTRODUCTION

This document covers safety requirements for secondary lithium cells and batteries for use in Electrical Energy Storage Systems and is under the umbrella standard IEC 62619 as shown in Figure 1. As an umbrella standard, IEC 62619 had been developed which covered various industrial applications in 2017.

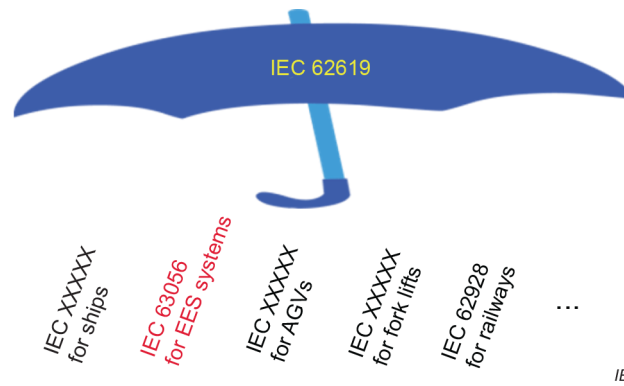

Figure 1 – IEC 62619 as umbrella standard to various industrial applications

SECONDARY CELLS AND BATTERIES CONTAINING ALKALINE OR OTHER NON-ACID ELECTROLYTES – SAFETY REQUIREMENTS FOR SECONDARY LITHIUM CELLS AND BATTERIES FOR USE IN ELECTRICAL ENERGY STORAGE SYSTEMS

1 Scope

This document specifies requirements and tests for the product safety of secondary lithium cells and batteries used in electrical energy storage systems (Figure 2) with a maximum DC voltage of 1 500 V (nominal).

Basic safety requirements for the secondary lithium cells and batteries used in industrial applications are included in IEC 62619. This document provides additional or specific requirements for electrical energy storage systems.

Since this document covers batteries for various electrical energy storage systems, it includes those requirements which are common and minimum to the electrical energy storage systems.

Examples of appliances that are within the scope of this document are:

- telecommunications,
- central emergency lighting and alarm systems,
- stationary engine starting,
- photovoltaic systems,
- home (residential) energy storage systems (HESS), and
- large energy storage: on-grid/off-grid

This document applies to cells and batteries for uninterruptible power supplies (UPS).

This document does not apply to portable systems 500 Wh or below, which are covered by IEC 61960-3.

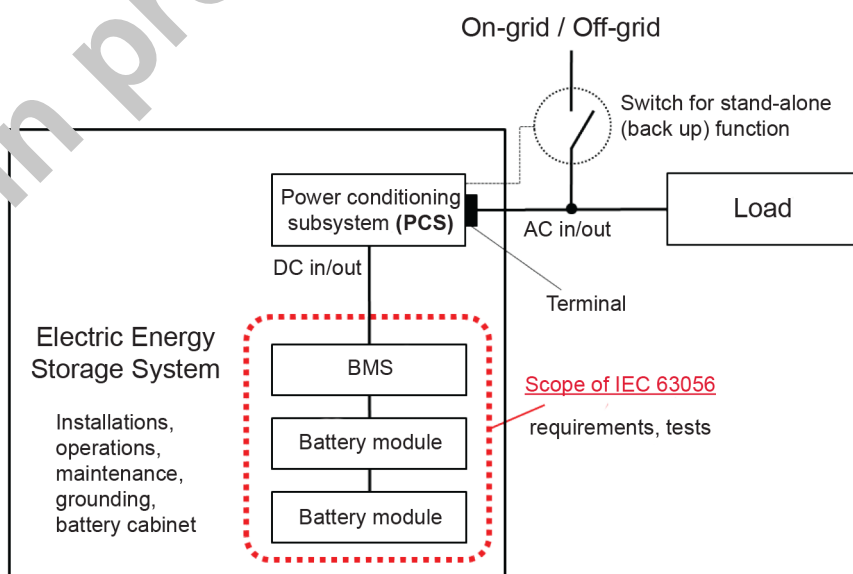

IEC

Figure 2 – Scope of IEC 63056