

CONSOLIDATED VERSION



Nuclear power plants – Instrumentation and control systems important to safety – Design and qualification of isolation devices



THIS PUBLICATION IS COPYRIGHT PROTECTED
Copyright © 2018 IEC, Geneva, Switzerland

All rights reserved. Unless otherwise specified, no part of this publication may be reproduced or utilized in any form or by any means, electronic or mechanical, including photocopying and microfilm, without permission in writing from either IEC or IEC's member National Committee in the country of the requester. If you have any questions about IEC copyright or have an enquiry about obtaining additional rights to this publication, please contact the address below or your local IEC member National Committee for further information.

IEC Central Office
3, rue de Varembe
CH-1211 Geneva 20
Switzerland

Tel.: +41 22 919 02 11
info@iec.ch
www.iec.ch

About the IEC

The International Electrotechnical Commission (IEC) is the leading global organization that prepares and publishes International Standards for all electrical, electronic and related technologies.

About IEC publications

The technical content of IEC publications is kept under constant review by the IEC. Please make sure that you have the latest edition, a corrigenda or an amendment might have been published.

IEC Catalogue - webstore.iec.ch/catalogue

The stand-alone application for consulting the entire bibliographical information on IEC International Standards, Technical Specifications, Technical Reports and other documents. Available for PC, Mac OS, Android Tablets and iPad.

IEC publications search - webstore.iec.ch/advsearchform

The advanced search enables to find IEC publications by a variety of criteria (reference number, text, technical committee,...). It also gives information on projects, replaced and withdrawn publications.

IEC Just Published - webstore.iec.ch/justpublished

Stay up to date on all new IEC publications. Just Published details all new publications released. Available online and also once a month by email.

Electropedia - www.electropedia.org

The world's leading online dictionary of electronic and electrical terms containing 21 000 terms and definitions in English and French, with equivalent terms in 16 additional languages. Also known as the International Electrotechnical Vocabulary (IEV) online.

IEC Glossary - webstore.iec.ch/glossary

67 000 electrotechnical terminology entries in English and French extracted from the Terms and Definitions clause of IEC publications issued since 2002. Some entries have been collected from earlier publications of IEC TC 37, 77, 86 and CISPR.

IEC Customer Service Centre - webstore.iec.ch/csc

If you wish to give us your feedback on this publication or need further assistance, please contact the Customer Service Centre: sales@iec.ch.

CONSOLIDATED VERSION



**Nuclear power plants – Instrumentation and control systems important
to safety – Design and qualification of isolation devices**

INTERNATIONAL
ELECTROTECHNICAL
COMMISSION

ICS 27.120.20

ISBN 978-2-8322-5738-8

Warning! Make sure that you obtained this publication from an authorized distributor.

Currently in preview, click buy full version

REDLINE VERSION



Nuclear power plants – Instrumentation and control systems important to safety – Design and qualification of isolation devices

CONTENTS

FOREWORD.....	3
INTRODUCTION.....	5
1 Scope.....	7
2 Normative references	7
3 Terms and definitions	7
4 Symbols and abbreviations.....	8
5 General principles for isolation devices.....	8
5.1 General.....	8
5.2 Isolation characteristics	9
5.3 Actuation priority.....	10
6 Isolation device design requirements	10
6.1 Requirements on isolation device application.....	10
6.1.1 Isolation device power	10
6.1.2 Maximum credible fault.....	10
6.1.3 Energy limiting devices.....	11
6.2 Requirements on isolation device design	11
6.2.1 Basic design requirements.....	11
6.2.2 Postulated faults.....	12
6.2.3 Physical component arrangement.....	12
6.3 Power isolation devices	13
6.3.1 General	13
6.3.2 Circuit breaker tripped by fault currents.....	13
6.3.3 Circuit breaker tripped by fault signals.....	13
6.3.4 Input current limiters.....	13
6.3.5 Fuses	13
7 Qualification test requirements.....	14
7.1 General.....	14
7.2 Requirements on the test method.....	14
7.2.1 Test specification.....	14
7.2.2 Testing energy limiting devices.....	14
7.2.3 Qualification test environment.....	14
7.3 Application specific testing.....	15
7.3.1 General	15
7.3.2 Isolation of safety circuits from lower class circuits.....	15
7.3.3 Isolation between redundant safety circuits.....	15
7.3.4 Documentation of test requirements and results.....	16
Bibliography.....	17
Figure 1 – Application of maximum credible fault	11
Figure 2 – Application of postulated fault	12

INTERNATIONAL ELECTROTECHNICAL COMMISSION

NUCLEAR POWER PLANTS – INSTRUMENTATION AND CONTROL SYSTEMS IMPORTANT TO SAFETY – DESIGN AND QUALIFICATION OF ISOLATION DEVICES

FOREWORD

- 1) The International Electrotechnical Commission (IEC) is a worldwide organization for standardization comprising all national electrotechnical committees (IEC National Committees). The object of IEC is to promote international co-operation on all questions concerning standardization in the electrical and electronic fields. To this end and in addition to other activities, IEC publishes International Standards, Technical Specifications, Technical Reports, Publicly Available Specifications (PAS) and Guides (hereafter referred to as “IEC Publication(s)”). Their preparation is entrusted to technical committees; any IEC National Committee interested in the subject dealt with may participate in this preparatory work. International, governmental and non-governmental organizations liaising with the IEC also participate in this preparation. IEC collaborates closely with the International Organization for Standardization (ISO) in accordance with conditions determined by agreement between the two organizations.
- 2) The formal decisions or agreements of IEC on technical matters express, as nearly as possible, an international consensus of opinion on the relevant subjects since each technical committee has representation from all interested IEC National Committees.
- 3) IEC Publications have the form of recommendations for international use and are accepted by IEC National Committees in that sense. While all reasonable efforts are made to ensure that the technical content of IEC Publications is accurate, IEC cannot be held responsible for the way in which they are used or for any misinterpretation by any end user.
- 4) In order to promote international uniformity, IEC National Committees undertake to apply IEC Publications transparently to the maximum extent possible in their national and regional publications. Any divergence between any IEC Publication and the corresponding national or regional publication shall be clearly indicated in the latter.
- 5) IEC itself does not provide any attestation of conformity. Independent certification bodies provide conformity assessment services and, in some areas, access to IEC marks of conformity. IEC is not responsible for any services carried out by independent certification bodies.
- 6) All users should ensure that they have the latest edition of this publication.
- 7) No liability shall attach to IEC or its directors, employees, servants or agents including individual experts and members of its technical committees and IEC National Committees for any personal injury, property damage or other damage of any nature whatsoever, whether direct or indirect, or for costs (including legal fees) and expenses arising out of the publication, use of, or reliance upon, this IEC Publication or any other IEC Publications.
- 8) Attention is drawn to the normative references cited in this publication. Use of the referenced publications is indispensable for the correct application of this publication.
- 9) Attention is drawn to the possibility that some of the elements of this IEC Publication may be the subject of patent rights. IEC shall not be held responsible for identifying any or all such patent rights.

DISCLAIMER

This Consolidated version is not an official IEC Standard and has been prepared for user convenience. Only the current versions of the standard and its amendment(s) are to be considered the official documents.

This Consolidated version of IEC 62808 bears the edition number 1.1. It consists of the first edition (2015-05) [documents 45A/1004/FDIS and 45A/1019/RVD] and its amendment 1 (2018-05) [documents 45A/1192/FDIS and 45A/1204/RVD]. The technical content is identical to the base edition and its amendment.

In this Redline version, a vertical line in the margin shows where the technical content is modified by amendment 1. Additions are in green text, deletions are in strikethrough red text. A separate Final version with all changes accepted is available in this publication.

International Standard IEC 62808 has been prepared by subcommittee 45A: Instrumentation, control and electrical systems of nuclear facilities, of IEC technical committee 45: Nuclear instrumentation.

This publication has been drafted in accordance with the ISO/IEC Directives, Part 2.

The committee has decided that the contents of the base publication and its amendment will remain unchanged until the stability date indicated on the IEC web site under "<http://webstore.iec.ch>" in the data related to the specific publication. At this date, the publication will be

- reconfirmed,
- withdrawn,
- replaced by a revised edition, or
- amended.

A bilingual version of this publication may be issued at a later date.

IMPORTANT – The 'colour inside' logo on the cover page of the publication indicates that it contains colours which are considered to be useful for the correct understanding of its contents. Users should therefore print this document using a colour printer.

INTRODUCTION

a) Technical background, main issues and organisation of the standard

I&C (instrumentation and control) systems important to safety in nuclear power plants need to tolerate the effects of plant / equipment faults as well as internal and external hazards. IEC 60709 provides requirements to establish independence between redundant portions of safety systems, and between safety systems and systems of a lower class. Among the techniques available to increase the level of tolerability of I&C systems to such effects is the provision of isolation devices where connections are made between redundant divisions of safety equipment, or between safety equipment and systems of a lower class. This standard provides technical requirements and recommendations for the design and qualification of isolation devices that are required by IEC 60709. This standard deals with the criteria and methods used to confirm that the design of isolation devices ensures that credible failure in the connected lower class system or redundant channels will not prevent the safety systems from meeting their required functions. Isolation devices may be required on power or signal interfaces within the system.

Guidance for other aspects of isolation device qualification (e.g. electromagnetic compatibility, environmental and seismic qualification) may be found in IEC 60780.

The object of this standard is:

- in Clause 5: to establish the basic criteria for acceptability of the design and application of isolation devices;
- in Clause 6: to establish design requirements on the selection and application of suitable isolation devices;
- in Clause 7: to establish requirements on qualification testing done to validate the adequacy of the isolation device design.

It is intended that the standard be used by operators of NPPs (utilities), designers of nuclear I&C system and equipment, systems evaluators and regulators.

b) Situation of the current standard in the structure of the IEC SC 45A standard series

IEC 62808 is the third level IEC SC 45A document tackling the issue of isolation devices.

IEC 60709 is directly referenced by IEC 61513 in regard to physical and electrical separation being required between subsystems of different safety trains of I&C systems important to safety, and between I&C systems important to safety and those that are not important to safety.

IEC 61226 establishes the principles of categorization of I&C functions, systems and equipment according to their level of importance to safety. It then requires that adequate separation be provided between functions of different categories. IEC 61226 refers to IEC 60709 as a normative standard regarding requirements of separation.

IEC 62808 is intended to provide requirements and recommendations relating to the design and qualification of isolation devices which are identified in IEC 60709 as a means of achieving independence between systems when signals are extracted from a system for use in lower class systems, or between independent subsystems of the same classes.

For more details on the structure of the IEC SC 45A standard series, see item d) of this introduction.

c) Recommendations and limitations regarding the application of this standard

IEC 60709 applies to I&C systems and equipment important to safety. It establishes requirements for physical and electrical separation as one means to provide independence between the functions performed in those systems and equipment. IEC 60709 requires the use of isolation devices where connections between independent systems must be made. IEC 62808 provides criteria for the analysis and qualification of the the isolation device.

A fundamental criterion for isolation devices is that they be included in, and designed to, the standards of the higher class system for which they provide protection against hazards. Additional requirements relating to design and qualification of an isolation device as an element of a safety system are not given in this standard.

d) Description of the structure of the IEC SC 45A standard series and relationships with other IEC documents and other bodies documents (IAEA, ISO)

The top-level document of the IEC SC 45A standard series is IEC 61513. It provides general requirements for I&C systems and equipment that are used to perform functions important to safety in NPPs. IEC 61513 structures the IEC SC 45A standard series.

IEC 61513 refers directly to other IEC SC 45A standards for general topics related to categorization of functions and classification of systems, qualification, separation of systems, defence against common cause failure, software aspects of computer-based systems, hardware aspects of computer-based systems, and control room design. The standards referenced directly at this second level should be considered together with IEC 61513 as a consistent document set.

At a third level, IEC SC 45A standards not directly referenced by IEC 61513 are standards related to specific equipment, technical methods or specific activities. Usually these documents, which make reference to second-level documents for general topics, can be used on their own.

A fourth level extending the IEC SC 45A standard series, corresponds to the Technical Reports which are not normative.

IEC 61513 has adopted a presentation format similar to the basic safety publication IEC 61508 with an overall safety life-cycle framework and a system life-cycle framework. Regarding nuclear safety, it provides the interpretation of the general requirements of IEC 61508-1, IEC 61508-2 and IEC 61508-4, for the nuclear application sector, regarding nuclear safety. In this framework IEC 60880 and IEC 62138 correspond to IEC 61508-3 for the nuclear application sector. IEC 61513 refers to ISO as well as to IAEA GS-R-3 and IAEA GS-G-3.1 and IAEA GS-G-3.5 for topics related to quality assurance (QA).

The IEC SC 45A standards series consistently implements and details the principles and basic safety aspects provided in the IAEA code on the safety of NPPs and in the IAEA safety series, in particular the Requirements SSR-2/1, establishing safety requirements related to the design of Nuclear Power Plants, and the Safety Guide NS-G-1.3 dealing with instrumentation and control systems important to safety in Nuclear Power Plants. The terminology and definitions used by SC 45A standards are consistent with those used by the IAEA.

NOTE It is assumed that for the design of I&C systems in NPPs that implement conventional safety functions (e.g. to address worker safety, asset protection, chemical hazards, process energy hazards), international or national standards would be applied, that are based on the requirements of a standard such as IEC 61508.

NUCLEAR POWER PLANTS – INSTRUMENTATION AND CONTROL SYSTEMS IMPORTANT TO SAFETY – DESIGN AND QUALIFICATION OF ISOLATION DEVICES

1 Scope

This International Standard establishes requirements for the design, analysis and qualification of isolation devices used to ensure electrical independence of redundant safety system circuits, or between safety and lower class circuits, as specified in IEC 60709. This standard includes guidance on the determination of the maximum credible fault that is applied to the isolation devices. The maximum credible fault can be used as a basis for the test levels used in testing based on other standards (e.g. IEC TS 61000-6-5 or IEC 62003).

This standard does not address safety or CCF issues due to functional inter-dependencies and possible interferences or CCFs that may result from signal exchange or sharing between systems or sub-systems. It also does not address design or qualification issues related to digital or programmable logic in isolation devices. For isolation devices containing digital or programmable logic, additional design and qualification requirements must be considered; these requirements are outside the scope of this standard.

2 Normative references

The following documents, in whole or in part, are normatively referenced in this document and are indispensable for its application. For dated references, only the edition cited applies. For undated references, the latest edition of the referenced document (including any amendments) applies.

IEC 60709, *Nuclear power plants – Instrumentation and control systems important to safety – Separation*

IEC TS 61000-6-5, *Electromagnetic compatibility (EMC) – Part 6-5: Generic standards – Immunity for power station and substation environments*

IEC 61513, *Nuclear power plants – Instrumentation and control important to safety – General requirements for systems*

IEC 62003, *Nuclear power plants – Instrumentation and control important to safety – Requirements for electromagnetic compatibility testing*

3 Terms and definitions

For the purposes of this document, the following terms and definitions apply.

3.1

barrier

device or structure interposed between redundant equipment or circuits important to safety, or between equipment or circuits important to safety and a potential source of damage to limit damage to the I&C system important to safety to an acceptable level

Note 1 to entry: The following definition is given in the IAEA Safety Glossary, edition 2007: “A physical obstruction that prevents or inhibits the movement of people, radionuclides or some other phenomenon (e.g. fire), or provides shielding against radiation”. The IAEA definition is more general and consistent with the definition given in this standard.

3.2

common mode electrical faults

voltage or current faults between both signal terminals and a common reference plane (ground)

Note 1 to entry: These faults should not be confused with common cause failures.

Note 2 to entry: This causes the potential of both signal terminals to be changed simultaneously and by the same amount relative to the common reference plane (ground).

3.3

differential mode electrical faults

voltage or current faults between signals

3.4

isolation device

device in a circuit that prevents malfunctions in one section of a circuit from causing unacceptable influences in other sections of the circuit or other circuits

Note 1 to entry: As described in IEC 60709, malfunctions can be caused by faults and normal actions.

3.5

maximum credible fault

MCF

voltage or current transient that may exist in circuits, as determined by test or analysis, taking into consideration the circuit location, routing, and interconnections combined with failures that the circuit and adjacent circuits may credibly experience

Note 1 to entry: The evaluation shall consider the impact of seismic and flooding conditions.

4 Symbols and abbreviations

AC	alternating current
CCF	common cause failure
DC	direct current
EMI	electromagnetic interference
I&C	instrumentation and control
MCF	maximum credible fault
NPP	nuclear power plant

5 General principles for isolation devices

5.1 General

The requirements for the application of isolation devices are in IEC 60709. Clause 5 is included as a summary and provides additional requirements for the isolation devices. The word "shall" identifies the additional requirements.

Isolation devices used in interfaces between I&C systems important to safety or between channels within a system important to safety may have an impact on the integrity of the overall design and in particular, on defence in depth. When used, they may be relied upon to provide electrical isolation between redundant safety functions or safety functions in different layers of defence in the overall architecture. In general, the introduction of such interfaces between systems should be considered carefully based on the principles and approaches outlined in IEC 61513. A systematic analysis of failures at system and overall I&C architecture level is required. Functional inter-dependencies are introduced between systems due to signal interfaces and their associated failure modes shall be considered carefully.

Where signals are transmitted between a Class 1 system or equipment (performing Category A functions) and systems of a lower class, the transmission of these signals are through isolation devices that are included within the higher class system. When failures or conditions are present at the output terminals of the isolation devices (which are connected to the lower class system) the safety action of the Class 1 system or sub-system to which the isolation device is connected cannot be affected. As an example, a circuit performing a Category A function may be monitored by a lower class circuit utilizing a relay coil in the Class 1 system and the relay contact in a lower class system.

Isolation devices are to be used where signals are transmitted between independent Class 1 systems and between redundant equipment channels of Class 1 systems.

Where signals are transmitted from Class 2 or 3 systems for use in lower class systems, or between independent subsystems in these classes, isolation devices may not be required; however, good engineering practices are followed to prevent the propagation of faults. In cases where Class 2 systems need to take on the aspects of Class 1 systems due to the functions performed, isolation is applied. An example of this is a Class 2 system performing a Category B function in support of a Class 1 system performing a Category A function to protect against the same fault.

Temporary connections for maintenance to systems performing Category A functions without isolation devices are only permitted provided that they are connected to only a single redundancy at any given time, that they are disconnected after use, and that the system is capable of withstanding a fault introduced through failure or use of the connection.

NOTE This standard discusses isolation devices as stand-alone devices which are separate from the equipment performing safety functions. The isolation device may be part of a module or equipment that performs a safety function. In other designs, the isolation device may be contained in several modules (e.g. one part handling rapid transient overvoltages and the other static voltages). This standard is also applicable to these design variations.

5.2 Isolation characteristics

The isolation device shall be capable of providing isolation against the following failure conditions:

- a) short-circuits between terminals or to ground;
- b) open circuits;
- c) application of the maximum AC or DC potential that could reasonably occur, considering potentials and sources available in both the Class 1 and non-Class 1 systems; and
- d) electromagnetic and electrostatic interference.

If the equipment can generate other signal types in fault conditions, such as a square wave or other form of oscillating signal in fault conditions, the isolation device shall be capable of providing isolation against such signals.

The properties of an isolation device shall include:

- tolerance of and isolation for the electrical transients defined in IEC TS 61000-6-5;
- tolerance and isolation for EMI to IEC TS 61000-6-5;
- simple physical barriers between close or adjacent terminals or contact groups on relay equipment used for electrical isolation; and
- prevention of transmission of excessively high or damaging voltages and/or currents.

In this context, an assessment shall be done of the maximum credible fault that could be envisaged under normal and faulted conditions and its potential effects on the equipment important to safety when applied to the isolation device terminals of the circuit of lesser safety class.

Precautions are also taken to minimise the possibility that failure in a non-Class 1 system causes spurious or premature actuation of a Category A function.

5.3 Actuation priority

Where plant equipment that is controlled by a Class 1 system is also controlled by a lower class system, devices are provided which ensure priority of the Class 1 system actions over those of the lower class systems. Failures of, or normal actions by, the lower class system cannot interfere with the Category A functions under plant conditions requiring success of those Category A functions. The equipment performing the priority function is classified as Class 1. The circuit that provides the required isolation could be within the same system, or may be in other systems.

Failures and mal-operations in the non-Class 1 systems cannot cause a change in response, drift, accuracy, sensitivity to noise, or other characteristics of the Class 1 system which might impair the ability of the system to perform its safety functions.

Where plant equipment that is controlled by a Class 2 or 3 system is also controlled by signals from a lower class system, failures, or normal actions by the lower class system cannot prevent the higher class system from performing its function.

Where signals are extracted from Class 2 or 3 systems for use in lower class systems, isolation may not be required; however, good engineering practices are followed to prevent the propagation of faults. In cases where Class 2 systems need to take on the aspects of Class 1 systems due to the functions performed (i.e. Category A functions), isolation is used.

6 Isolation device design requirements

6.1 Requirements on isolation device application

6.1.1 Isolation device power

Isolation devices are classified as part of the safety system and are powered in accordance with the criteria of IEC 61513 if a power supply is necessary for the function. The power supply of the isolation device shall not be required for the device to perform its isolation function.

6.1.2 Maximum credible fault

Maximum credible fault (MCF) requirements shall be established by analysis of neighbouring circuits that are credible sources of the fault, either through inadvertent application from human error or through a fault or failure postulated to occur that involves proximate circuits, cabling, or terminations (e.g., a "hot short" from an adjacent conductor). The circuits that shall be analyzed depend on how the isolation device is used. The circuits could be within the same system, or may be in other systems.

The highest voltage to which the faulted side of the isolation device maybe exposed to shall determine the minimum voltage level that the device shall withstand. This voltage shall be applied across the faulted side terminals, and between the faulted side terminals and ground (see Figure 1). Transient voltages that may appear in the faulted side shall also be considered. Surge waveforms and characteristics shall be defined for the worst-case conditions expected at the installation.

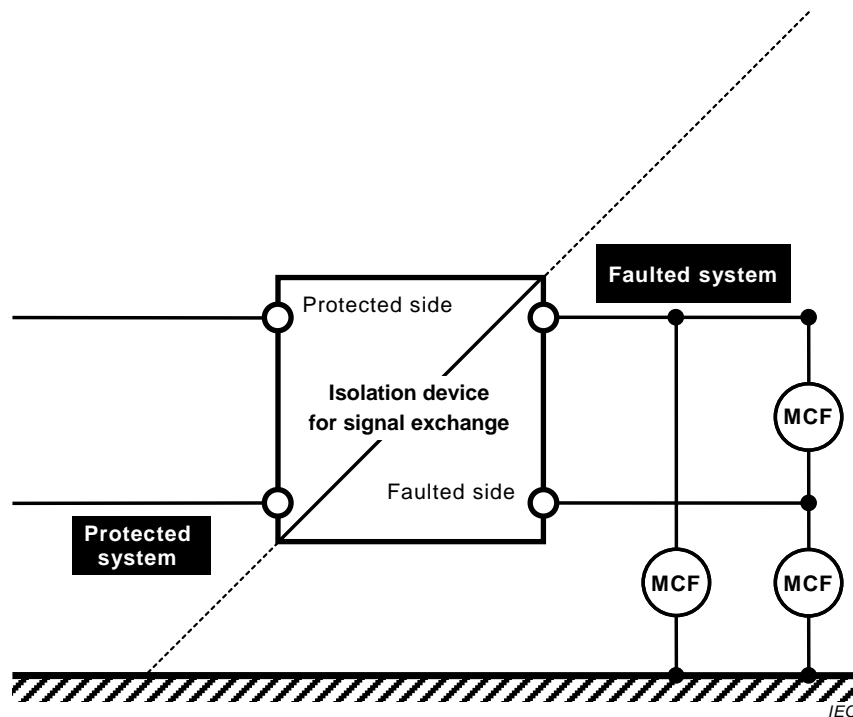

Figure 1 – Application of maximum credible fault

The MCF voltage shall be the highest AC or DC voltage present in an enclosure containing the conductors of the faulted side circuit of the isolation device, or in any proximate cable raceway which may collapse on to the raceway containing the lower class circuit of the isolation device. Where grounded metallic barriers separate the isolated circuit from higher voltages, those voltages may be excluded from consideration of the MCF provided that the barriers and grounding measures are designed to withstand the design basis hazards (induced vibrations due to design basis earthquakes or air plane crash, fire, etc.) for the plant.

In establishing the MCF voltage and current, the analysis shall include the consequences of flooding or fire causing a fault voltage to be introduced on a signal line from a proximate circuit or cable.

The available fault current for a direct short to ground shall be determined for each MCF source.

6.1.3 Energy limiting devices

Energy limiting devices (e.g. fuses for current or suppressors for voltage) may be used to limit the fault energy that must be dissipated in the isolation device or which may be available to be transferred to the protected circuits. In such cases, the energy limiting devices shall be considered to be part of the isolation device, even if they are separately packaged. Effective surveillance procedures shall be implemented to verify during plant operation that the energy limiting devices are properly in place and capable of performing their claimed role.

6.2 Requirements on isolation device design

6.2.1 Basic design requirements

The design of isolation devices conforms to IEC 61513 for:

- independence of redundant safety divisions, and
- independence between protection and control systems.

The isolation device shall include design features for which credit is taken (e.g., surge protectors or barriers) and shall identify the application limits of the device.

6.2.2 Postulated faults

The device shall be designed for postulated electrical faults or failures. The impact on the protected side for each fault shall be determined. As a minimum, the following faults shall be defined on the faulted side of the isolation device (see Figure 2):

- (a) short circuit to supply voltage if the isolation device is powered from the faulted side;
- (b1) short circuit between the faulted side terminals;
- (b2) short circuit between each faulted side terminal and ground;
- (c) open circuit of faulted side;
- (MCF) MCF between each faulted side terminal and ground;
- (MCF) MCF between faulted side terminals.

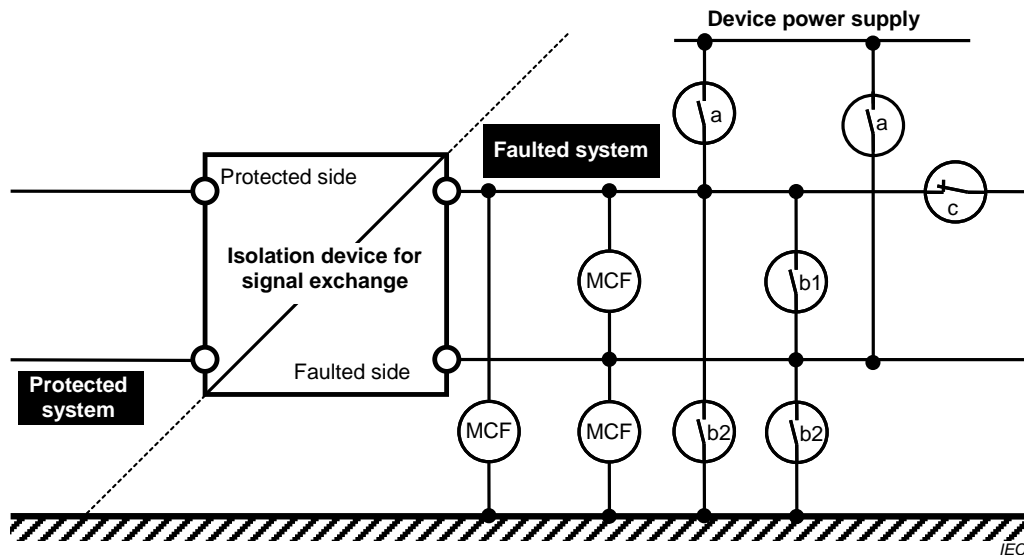

Figure 2 – Application of postulated fault

The specified MCF shall equal or exceed the application requirements. The device design shall accommodate the fault voltage and current waveforms and characteristics defined for the application. Appropriate industry standards shall be used as a basis for establishing the fault-transient exposure level (e.g. IEC TS 61000-6-5 or IEC 62003). The testing shall use the MCF as a basis for the test levels.

6.2.3 Physical component arrangement

The physical arrangement of components in the isolation device shall be configured to prevent, in the event of failure, the effects of shattered parts or material (e.g., solder spatter), fire, and smoke from breaching the isolation barrier.

Circuit terminals shall be arranged to permit the IEC 60709 specified separation distance between conductors associated with functions of different categories to be established as soon as practical. Minimum separation requirements do not apply for wiring and components within the isolation device; however, separation should be provided wherever practicable.

6.3 Power isolation devices

6.3.1 General

When the maximum credible voltage or current transient are applied to the faulted side of the power isolation device, the operation of the circuit on the protected side of that device will not be affected.

6.3.2 Circuit breaker tripped by fault currents

A circuit breaker automatically tripped by fault current is considered an isolation device, provided the following criteria are met:

- a) The breaker time-overcurrent trip characteristic for all circuit faults shall cause the breaker to interrupt the fault current prior to initiation of a trip of any upstream breaker. Periodic testing shall demonstrate that the overall coordination scheme remains within the limits specified in the design criteria. This testing may be performed as a series of overlapping tests.
- b) The power source shall supply the necessary fault current for sufficient time to ensure the proper coordination without loss of function of safety class loads. (For example, diesel generator excitation systems should be capable of providing the required transient current during faults.)

~~c) The voltage on the protected side shall not degrade below an acceptable level.~~

6.3.3 Circuit breaker tripped by fault signals

A circuit breaker can be considered an isolation device provided it shall be automatically tripped by a signal generated within the same division as that to which the isolation device is applied. The time delay involved in generating the fault signal and tripping the breaker shall not cause unacceptable degradation of the safety power system.

6.3.4 Input current limiters

Devices that will limit the input current to an acceptable value under faulted conditions of the output are considered isolation devices. ~~Periodic testing shall verify that the current-limiting characteristic has not been compromised or lost.~~ Devices in this category may include inverters, regulating transformers, ~~and~~ battery chargers ~~uninterruptible power supply, etc.,~~ with current limiting characteristics. ~~It shall be verified periodically that the current-limiting characteristics have not been compromised or lost. This periodic verification should be done with a test, or an alternative means to demonstrate operability.~~

~~The alternative means of demonstration may include tests performed within the uninterruptible power supply which check internal protection clearing time, or preventive replacement of protection devices within a specified maintenance interval.~~

6.3.5 Fuses

A fuse may be used as a power isolation device if the following criteria are met:

- a) Fuses shall provide the design overcurrent protection capability for the life of the fuse.
- b) The fuse time-overcurrent trip characteristic for all circuit faults shall cause the fuse to open prior to the initiation of an opening of any upstream interrupting device.
- c) The power source shall supply the necessary fault current to ensure the proper coordination without loss of function of safety loads.

The effects of single-phasing shall be considered for three-phase AC circuits.

7 Qualification test requirements

7.1 General

Qualification of isolation devices shall be based on a combination of design analysis and qualification testing. Clause 7 addresses the testing portion of the qualification. The objective of the testing is to validate the results of the analysis at the extremes of fault conditions.

7.2 Requirements on the test method

7.2.1 Test specification

A specification shall be prepared for the specific testing that is to be performed for each type of isolation device. The test specification should include elementary or schematic diagrams as necessary to describe the test configuration and how the MCF and surges shall be applied to the devices during the test. The basis for the set of postulated electrical faults and failures shall be documented or referenced in the test program.

A specific definition of pass/fail acceptance criteria for each type of device shall be provided. This shall include justification that the pass/fail acceptance criterion is sufficient to evaluate the safety system performance, and to demonstrate that the tested device meets the requirements of IEC 61513 and IEC 60709 when used in the system. In particular, the following points shall be included:

- The maximum credible voltage or current transient applied to the faulted side of the device shall not degrade below an acceptable level (i.e. to prevent the safety function) the operation of the circuit connected to the protected side of the device.
- Shorts, grounds, or open circuits occurring in the faulted side shall not degrade below an acceptable level the circuit connected to the protected side of the device.
- Transient voltages that may appear in the faulted side circuit (e.g., surges) should also be considered.
- The qualification shall consider the levels and duration of the fault current on the faulted side of the device.

For isolation between systems of different classes, during and following the application of the MCF or surge test, there shall be no degradation or distortion of the isolation device input that would have a detrimental effect on the performance of the safety system. For isolation of redundant safety circuits, there shall be no degradation or distortion of the redundant channel that would have a detrimental effect on the performance of the safety system.

Applicable industry standards shall be used as the basis for performing the qualification testing (e.g. IEC TS 61000-6-5 or IEC 62003). The testing shall use the MCF as a basis for the test levels.

7.2.2 Testing energy limiting devices

When the isolation device contains devices that limit the energy (e.g. fuses or suppressors), the qualification testing shall include cases where the applied voltage and current is less than that necessary to activate the limiting devices in addition to testing at worst case conditions where the limiting devices will become active.

7.2.3 Qualification test environment

Qualification of isolation devices shall be carried out on samples prior to installation. Testing entails applying the postulated faults to the faulted side terminals and recording the electrical signals and observing the physical integrity at the protected side terminals. Any disturbance that is seen shall be evaluated to determine if there would be an effect on the safety system. If an evaluation cannot demonstrate that the safety system would not be affected, testing shall be repeated with the device connected to the safety system equipment for all the

configurations where the device is intended to be used. The performance of the system shall be monitored to demonstrate operability throughout the test. Requirements for testing the device in the system are provided in 7.3.

7.3 Application specific testing

7.3.1 General

Devices might be used either for isolation of safety circuits from lower class circuits or for isolation of redundant safety divisions. For qualification testing, the detailed device configuration depends on the objective of the isolation and the specific type and configuration of the isolation.

The MCF represents the application of the maximum credible AC and DC voltages and currents that are applied to the device in common and differential modes that exist based on the installation of the device. Common mode refers to faults between both signal terminals and a common reference plane (ground) and causes the potential of both sides of the transmission path to be changed simultaneously and by the same amount relative to the common reference plane (ground). Differential mode refers to faults between the signal terminals that cause the potential of one side of the signal transmission path to be changed relative to the other side. The mode of application shall satisfy the following guidelines for test configurations.

7.3.2 Isolation of safety circuits from lower class circuits

MCFs and surges shall be applied between the faulted side terminals of the (lower class) circuits (differential mode) and between any faulted side terminal and ground (common mode).

MCFs and surges shall be applied to any power terminals that provide power to the faulted side of the isolation device.

The protected side terminals shall be monitored to ensure that no unacceptable interactions (degradations or distortions) between lower class and safety circuits would occur.

7.3.3 Isolation between redundant safety circuits

MCFs shall be applied between the faulted side terminals (differential mode) and between any faulted side terminal and ground (common mode); the other side shall be monitored to ensure that no unacceptable interactions (degradations or distortions) between redundant safety circuits will occur.

If the isolation device performs its protective function in two directions, the MCF shall be applied separately on both sides.

MCFs shall be applied to the isolation device for a sufficient duration to allow any measurable effects to occur on the isolation device and to allow monitored values or effects to reach steady-state.

7.4 Documentation of test requirements and results

The test specification and acceptance criteria shall be documented in advance of the test.

Test data and results shall be documented to verify that the design basis faults, including short circuits, open circuits, grounds, MCF, and surge were applied to the device in all of the applicable connection modes (i.e. applicable input, output, power, and ground connection modes).

Test data and results shall verify that the test acceptance criteria are met.

Bibliography

IEC 60780, *Nuclear power plants – Electrical equipment of the safety system – Qualification*

IEC 60880, *Nuclear power plants – Instrumentation and control systems important to safety – Software aspects for computer-based systems performing category A functions*

IEC 61226:2009, *Nuclear power plants – Instrumentation and control important to safety – Classification of instrumentation and control functions*

IEC 61508-1, *Functional safety of electrical/electronic/programmable electronic safety-related systems – Part 1: General requirements*

IEC 61508-2, *Functional safety of electrical/electronic/programmable electronic safety-related systems – Part 2: Requirements for electrical/electronic/programmable electronic safety-related systems*

IEC 61508-3, *Functional safety of electrical/electronic/programmable electronic safety-related systems – Part 3: Software requirements*

IEC 61508-4, *Functional safety of electrical/electronic/programmable electronic safety-related systems – Part 4: Definitions and abbreviations*

IEC 62138, *Nuclear power plants – Instrumentation and control systems important to safety – Software aspects for computer-based systems performing category B or C functions*

IAEA GS-R-3:2006, *The management system for facilities and activities*

IAEA Safety Guide No, GS-G-3.1:2006, *Application of the management System for facilities and activities*

IAEA Safety Guide No, GS-G-3.5:2009, *Management system for nuclear installations*

IAEA Safety Standard Series No. SSR-2/1:2012, *Safety of Nuclear Power Plant: Design*

IAEA Safety Guide NS-G-1.3:2002, *Instrumentation and Control Systems Important to Safety in Nuclear Power Plants*

IAEA Safety Glossary:2007, *Terminology used in nuclear safety and radiation protection*

FINAL VERSION

Nuclear power plants – Instrumentation and control systems important to safety – Design and qualification of isolation devices



CONTENTS

FOREWORD.....	3
INTRODUCTION.....	5
1 Scope.....	7
2 Normative references	7
3 Terms and definitions	7
4 Symbols and abbreviations.....	8
5 General principles for isolation devices.....	8
5.1 General.....	8
5.2 Isolation characteristics	9
5.3 Actuation priority.....	10
6 Isolation device design requirements	10
6.1 Requirements on isolation device application.....	10
6.1.1 Isolation device power	10
6.1.2 Maximum credible fault.....	10
6.1.3 Energy limiting devices	11
6.2 Requirements on isolation device design	11
6.2.1 Basic design requirements.....	11
6.2.2 Postulated faults.....	12
6.2.3 Physical component arrangement	12
6.3 Power isolation devices	13
6.3.1 General	13
6.3.2 Circuit breaker tripped by fault currents	13
6.3.3 Circuit breaker tripped by fault signals.....	13
6.3.4 Input current limiters.....	13
6.3.5 Fuses	13
7 Qualification test requirements	14
7.1 General.....	14
7.2 Requirements on the test method.....	14
7.2.1 Test specification.....	14
7.2.2 Testing energy limiting devices	14
7.2.3 Qualification test environment.....	14
7.3 Application specific testing.....	15
7.3.1 General	15
7.3.2 Isolation of safety circuits from lower class circuits	15
7.3.3 Isolation between redundant safety circuits.....	15
7.4 Documentation of test requirements and results.....	16
Bibliography.....	17
Figure 1 – Application of maximum credible fault	11
Figure 2 – Application of postulated fault	12

INTERNATIONAL ELECTROTECHNICAL COMMISSION

NUCLEAR POWER PLANTS – INSTRUMENTATION AND CONTROL SYSTEMS IMPORTANT TO SAFETY – DESIGN AND QUALIFICATION OF ISOLATION DEVICES

FOREWORD

- 1) The International Electrotechnical Commission (IEC) is a worldwide organization for standardization comprising all national electrotechnical committees (IEC National Committees). The object of IEC is to promote international co-operation on all questions concerning standardization in the electrical and electronic fields. To this end and in addition to other activities, IEC publishes International Standards, Technical Specifications, Technical Reports, Publicly Available Specifications (PAS) and Guides (hereafter referred to as "IEC Publication(s)"). Their preparation is entrusted to technical committees; any IEC National Committee interested in the subject dealt with may participate in this preparatory work. International, governmental and non-governmental organizations liaising with the IEC also participate in this preparation. IEC collaborates closely with the International Organization for Standardization (ISO) in accordance with conditions determined by agreement between the two organizations.
- 2) The formal decisions or agreements of IEC on technical matters express, as nearly as possible, an international consensus of opinion on the relevant subjects since each technical committee has representation from all interested IEC National Committees.
- 3) IEC Publications have the form of recommendations for international use and are accepted by IEC National Committees in that sense. While all reasonable efforts are made to ensure that the technical content of IEC Publications is accurate, IEC cannot be held responsible for the way in which they are used or for any misinterpretation by any end user.
- 4) In order to promote international uniformity, IEC National Committees undertake to apply IEC Publications transparently to the maximum extent possible in their national and regional publications. Any divergence between any IEC Publication and the corresponding national or regional publication shall be clearly indicated in the latter.
- 5) IEC itself does not provide any attestation of conformity. Independent certification bodies provide conformity assessment services and, in some areas, access to IEC marks of conformity. IEC is not responsible for any services carried out by independent certification bodies.
- 6) All users should ensure that they have the latest edition of this publication.
- 7) No liability shall attach to IEC or its directors, employees, servants or agents including individual experts and members of its technical committees and IEC National Committees for any personal injury, property damage or other damage of any nature whatsoever, whether direct or indirect, or for costs (including legal fees) and expenses arising out of the publication, use of, or reliance upon, this IEC Publication or any other IEC Publications.
- 8) Attention is drawn to the Normative references cited in this publication. Use of the referenced publications is indispensable for the correct application of this publication.
- 9) Attention is drawn to the possibility that some of the elements of this IEC Publication may be the subject of patent rights. IEC shall not be held responsible for identifying any or all such patent rights.

DISCLAIMER

This Consolidated version is not an official IEC Standard and has been prepared for user convenience. Only the current versions of the standard and its amendment(s) are to be considered the official documents.

This Consolidated version of IEC 62808 bears the edition number 1.1. It consists of the first edition (2015-05) [documents 45A/1004/FDIS and 45A/1019/RVD] and its amendment 1 (2018-05) [documents 45A/1192/FDIS and 45A/1204/RVD]. The technical content is identical to the base edition and its amendment.

This Final version does not show where the technical content is modified by amendment 1. A separate Redline version with all changes highlighted is available in this publication.

International Standard IEC 62808 has been prepared by subcommittee 45A: Instrumentation, control and electrical systems of nuclear facilities, of IEC technical committee 45: Nuclear instrumentation.

This publication has been drafted in accordance with the ISO/IEC Directives, Part 2.

The committee has decided that the contents of the base publication and its amendment will remain unchanged until the stability date indicated on the IEC web site under "<http://webstore.iec.ch>" in the data related to the specific publication. At this date, the publication will be

- reconfirmed,
- withdrawn,
- replaced by a revised edition, or
- amended.

A bilingual version of this publication may be issued at a later date.

INTRODUCTION

a) Technical background, main issues and organisation of the standard

I&C (instrumentation and control) systems important to safety in nuclear power plants need to tolerate the effects of plant / equipment faults as well as internal and external hazards. IEC 60709 provides requirements to establish independence between redundant portions of safety systems, and between safety systems and systems of a lower class. Among the techniques available to increase the level of tolerability of I&C systems to such effects is the provision of isolation devices where connections are made between redundant divisions of safety equipment, or between safety equipment and systems of a lower class. This standard provides technical requirements and recommendations for the design and qualification of isolation devices that are required by IEC 60709. This standard deals with the criteria and methods used to confirm that the design of isolation devices ensures that credible failures in the connected lower class system or redundant channels will not prevent the safety systems from meeting their required functions. Isolation devices may be required on power or signal interfaces within the system.

Guidance for other aspects of isolation device qualification (e.g. electromagnetic compatibility, environmental and seismic qualification) may be found in IEC 60780.

The object of this standard is:

- in Clause 5: to establish the basic criteria for acceptability of the design and application of isolation devices;
- in Clause 6: to establish design requirements on the selection and application of suitable isolation devices;
- in Clause 7: to establish requirements on qualification testing done to validate the adequacy of the isolation device design.

It is intended that the standard be used by operators of NPPs (utilities), designers of nuclear I&C system and equipment, systems evaluators and regulators.

b) Situation of the current standard in the structure of the IEC SC 45A standard series

IEC 62808 is the third level IEC SC 45A document tackling the issue of isolation devices.

IEC 60709 is directly referenced by IEC 61513 in regard to physical and electrical separation being required between subsystems of different safety trains of I&C systems important to safety, and between I&C systems important to safety and those that are not important to safety.

IEC 61226 establishes the principles of categorization of I&C functions, systems and equipment according to their level of importance to safety. It then requires that adequate separation be provided between functions of different categories. IEC 61226 refers to IEC 60709 as a normative standard regarding requirements of separation.

IEC 62808 is intended to provide requirements and recommendations relating to the design and qualification of isolation devices which are identified in IEC 60709 as a means of achieving independence between systems when signals are extracted from a system for use in lower class systems, or between independent subsystems of the same classes.

For more details on the structure of the IEC SC 45A standard series, see item d) of this introduction.

c) Recommendations and limitations regarding the application of this standard

IEC 60709 applies to I&C systems and equipment important to safety. It establishes requirements for physical and electrical separation as one means to provide independence between the functions performed in those systems and equipment. IEC 60709 requires the use of isolation devices where connections between independent systems must be made. IEC 62808 provides criteria for the analysis and qualification of the the isolation device.

A fundamental criterion for isolation devices is that they be included in, and designed to, the standards of the higher class system for which they provide protection against hazards. Additional requirements relating to design and qualification of an isolation device as an element of a safety system are not given in this standard.

d) Description of the structure of the IEC SC 45A standard series and relationships with other IEC documents and other bodies documents (IAEA, ISO)

The top-level document of the IEC SC 45A standard series is IEC 61513. It provides general requirements for I&C systems and equipment that are used to perform functions important to safety in NPPs. IEC 61513 structures the IEC SC 45A standard series.

IEC 61513 refers directly to other IEC SC 45A standards for general topics related to categorization of functions and classification of systems, qualification, separation of systems, defence against common cause failure, software aspects of computer-based systems, hardware aspects of computer-based systems, and control room design. The standards referenced directly at this second level should be considered together with IEC 61513 as a consistent document set.

At a third level, IEC SC 45A standards not directly referenced by IEC 61513 are standards related to specific equipment, technical methods, or specific activities. Usually these documents, which make reference to second-level documents for general topics, can be used on their own.

A fourth level extending the IEC SC 45A standard series, corresponds to the Technical Reports which are not normative.

IEC 61513 has adopted a presentation format similar to the basic safety publication IEC 61508 with an overall safety life-cycle framework and a system life-cycle framework. Regarding nuclear safety, it provides the interpretation of the general requirements of IEC 61508-1, IEC 61508-2 and IEC 61508-4, for the nuclear application sector, regarding nuclear safety. In this framework IEC 60880 and IEC 62138 correspond to IEC 61508-3 for the nuclear application sector. IEC 61513 refers to ISO as well as to IAEA GS-R-3 and IAEA GS-G-3.1 and IAEA GS-G-3.5 for topics related to quality assurance (QA).

The IEC SC 45A standards series consistently implements and details the principles and basic safety aspects provided in the IAEA code on the safety of NPPs and in the IAEA safety series, in particular the Requirements SSR-2/1, establishing safety requirements related to the design of Nuclear Power Plants, and the Safety Guide NS-G-1.3 dealing with instrumentation and control systems important to safety in Nuclear Power Plants. The terminology and definitions used by SC 45A standards are consistent with those used by the IAEA.

NOTE It is assumed that for the design of I&C systems in NPPs that implement conventional safety functions (e.g. to address worker safety, asset protection, chemical hazards, process energy hazards), international or national standards would be applied, that are based on the requirements of a standard such as IEC 61508.

NUCLEAR POWER PLANTS – INSTRUMENTATION AND CONTROL SYSTEMS IMPORTANT TO SAFETY – DESIGN AND QUALIFICATION OF ISOLATION DEVICES

1 Scope

This International Standard establishes requirements for the design, analysis and qualification of isolation devices used to ensure electrical independence of redundant safety system circuits, or between safety and lower class circuits, as specified in IEC 60709. This standard includes guidance on the determination of the maximum credible fault that is applied to the isolation devices. The maximum credible fault can be used as a basis for the test levels used in testing based on other standards (e.g. IEC TS 61000-6-5 or IEC 62003).

This standard does not address safety or CCF issues due to functional inter-dependencies and possible interferences or CCFs that may result from signal exchange or sharing between systems or sub-systems. It also does not address design or qualification issues related to digital or programmable logic in isolation devices. For isolation devices containing digital or programmable logic, additional design and qualification requirements must be considered; these requirements are outside the scope of this standard.

2 Normative references

The following documents, in whole or in part, are normatively referenced in this document and are indispensable for its application. For dated references, only the edition cited applies. For undated references, the latest edition of the referenced document (including any amendments) applies.

IEC 60709, *Nuclear power plants – Instrumentation and control systems important to safety – Separation*

IEC TS 61000-6-5, *Electromagnetic compatibility (EMC) – Part 6-5: Generic standards – Immunity for power station and substation environments*

IEC 61513, *Nuclear power plants – Instrumentation and control important to safety – General requirements for systems*

IEC 62003, *Nuclear power plants – Instrumentation and control important to safety – Requirements for electromagnetic compatibility testing*

3 Terms and definitions

For the purposes of this document, the following terms and definitions apply.

3.1

barrier

device or structure interposed between redundant equipment or circuits important to safety, or between equipment or circuits important to safety and a potential source of damage to limit damage to the I&C system important to safety to an acceptable level

Note 1 to entry: The following definition is given in the IAEA Safety Glossary, edition 2007: “A physical obstruction that prevents or inhibits the movement of people, radionuclides or some other phenomenon (e.g. fire), or provides shielding against radiation”. The IAEA definition is more general and consistent with the definition given in this standard.