

# INTERNATIONAL STANDARD



**Power line communication systems for power utility applications –  
Part 2: Analogue power line carrier terminals for PLC**



## THIS PUBLICATION IS COPYRIGHT PROTECTED

Copyright © 2017 IEC, Geneva, Switzerland

All rights reserved. Unless otherwise specified, no part of this publication may be reproduced or utilized in any form or by any means, electronic or mechanical, including photocopying and microfilm, without permission in writing from either IEC or IEC's member National Committee in the country of the requester. If you have any questions about IEC copyright or have an enquiry about obtaining additional rights to this publication, please contact the address below or your local IEC member National Committee for further information.

IEC Central Office  
3, rue de Varembe  
CH-1211 Geneva 20  
Switzerland

Tel.: +41 22 919 02 11  
Fax: +41 22 919 03 00  
[info@iec.ch](mailto:info@iec.ch)  
[www.iec.ch](http://www.iec.ch)

### About the IEC

The International Electrotechnical Commission (IEC) is the leading global organization that prepares and publishes International Standards for all electrical, electronic and related technologies.

### About IEC publications

The technical content of IEC publications is kept under constant review by the IEC. Please make sure that you have the latest edition, a corrigenda or an amendment might have been published.

#### IEC Catalogue - [webstore.iec.ch/catalogue](http://webstore.iec.ch/catalogue)

The stand-alone application for consulting the entire bibliographical information on IEC International Standards, Technical Specifications, Technical Reports and other documents. Available for PC, Mac OS, Android Tablets and iPad.

#### IEC publications search - [www.iec.ch/searchpub](http://www.iec.ch/searchpub)

The advanced search enables to find IEC publications by a variety of criteria (reference number, text, technical committee,...). It also gives information on projects, replaced and withdrawn publications.

#### IEC Just Published - [webstore.iec.ch/justpublished](http://webstore.iec.ch/justpublished)

Stay up to date on all new IEC publications. Just Published details all new publications released. Available online and also once a month by email.

#### Electropedia - [www.electropedia.org](http://www.electropedia.org)

The world's leading online dictionary of electronic and electrical terms containing 20 000 terms and definitions in English and French, with equivalent terms in 16 additional languages. Also known as the International Electrotechnical Vocabulary (IEV) online.

#### IEC Glossary - [www.iec.ch/glossary](http://www.iec.ch/glossary)

65 000 electrotechnical terminology entries in English and French extracted from the Terms and Definitions clause of IEC publications issued since 2002. Some entries have been collected from earlier publications of IEC TC 37, 77, 86 and CISPR.

#### IEC Customer Service Centre - [webstore.iec.ch/csc](http://webstore.iec.ch/csc)

If you wish to give us your feedback on this publication or need further assistance, please contact the Customer Service Centre: [csc@iec.ch](mailto:csc@iec.ch).

# INTERNATIONAL STANDARD



---

**Power line communication systems for power utility applications –  
Part 2: Analogue power line carrier terminals for PLC**

INTERNATIONAL  
ELECTROTECHNICAL  
COMMISSION

---

ICS 33.200

ISBN 978-2-8322-4507-1

**Warning! Make sure that you obtained this publication from an authorized distributor.**

## CONTENTS

FOREWORD.....	7
INTRODUCTION.....	9
1 Scope.....	10
2 Normative references .....	11
3 Terms, definitions and abbreviations .....	13
3.1 Terms and definitions.....	13
3.2 Abbreviations .....	15
4 Low frequency side interfaces .....	16
4.1 General.....	16
4.2 Analogue interfaces .....	17
4.2.1 General .....	17
4.2.2 Voice frequency band .....	17
4.2.3 Nominal impedance .....	17
4.2.4 Return loss .....	17
4.2.5 Degree of unbalance to Earth .....	17
4.2.6 ITU-T voice channel interface .....	17
4.2.7 Subscriber interface.....	17
4.2.8 PBX interconnection interface.....	18
4.2.9 Narrowband telegraphic channel interface .....	18
4.3 Analogue teleprotection system interface .....	19
4.3.1 Description .....	19
4.3.2 Integrated teleprotection.....	20
4.3.3 Teleprotection interface frequency band .....	20
4.3.4 Teleprotection interface impedance .....	20
4.3.5 Teleprotection interface reflection.....	20
4.3.6 Teleprotection interface signal levels .....	20
4.3.7 Teleprotection interface control circuits.....	20
4.4 Digital interfaces.....	21
4.4.1 Telephony signaling interface .....	21
4.4.2 Internal data modem.....	21
5 Transmission line side high frequency interface.....	24
5.1 APLC high frequency band and channelling .....	24
5.2 Frequency accuracy.....	25
5.3 Signal levels .....	25
5.4 Nominal impedance .....	25
5.5 Return loss .....	25
5.6 Degree of unbalance to earth.....	25
5.7 Tapping loss .....	25
5.8 Spurious emissions.....	26
6 Quality and Performance .....	27
6.1 General.....	27
6.2 APLC internally generated noise .....	28
6.3 Automatic gain control .....	28
6.4 Limiter action .....	28
6.5 Transmit/Receive frequency difference .....	28
6.6 Attenuation distortion .....	28

6.7	Group-delay distortion.....	30
6.8	Harmonic distortion.....	31
6.9	Selectivity.....	31
6.10	Crosstalk attenuation.....	31
6.10.1	Co-channel crosstalk attenuation.....	31
6.10.2	Inter-channel crosstalk attenuation.....	31
7	Testing.....	32
7.1	General.....	32
7.2	Test setup for APLC link tests.....	32
7.3	Return loss.....	32
7.4	Degree of unbalance to earth.....	33
7.4.1	General.....	33
7.4.2	LCL.....	34
7.4.3	OSB.....	34
7.5	Tapping loss.....	35
7.6	Spurious emissions.....	36
7.6.1	Single channel terminals.....	36
7.6.2	Multi-channel terminals.....	36
7.7	Selectivity.....	36
7.8	Co-channel and inter-channel crosstalk attenuation.....	37
8	Configuration and management.....	37
8.1	General.....	37
8.2	Configuration.....	37
8.3	Network management system.....	38
8.4	Local terminal alarms.....	38
9	Cyber security.....	38
9.1	General.....	38
9.2	Authentication.....	39
10	APLC safety.....	39
10.1	General.....	39
10.2	Safety reference standard.....	39
10.3	Classification of APLC Terminals.....	39
10.4	Ingress protection.....	41
10.5	Type and routine tests.....	41
11	Storage and transportation, operating conditions, power supply.....	43
11.1	Storage and transportation.....	43
11.1.1	Climatic conditions.....	43
11.1.2	Mechanical.....	44
11.2	Operating conditions.....	45
11.2.1	Climatic conditions.....	45
11.2.2	Mechanical.....	46
11.2.3	Operating conditions set of tests.....	47
11.3	Power supply.....	48
11.3.1	AC supply.....	48
11.3.2	DC supply.....	48
12	EMC.....	49
12.1	Emission and Immunity reference standards.....	49
12.2	Emission.....	50

12.2.1	Radiated and conducted emission .....	50
12.2.2	Low frequency disturbance emission .....	54
12.3	Immunity .....	54
12.3.1	EMC Environment.....	54
12.3.2	Functional requirements .....	56
12.3.3	Immunity test list .....	56
Annex A (normative) Characteristics of compandors for telephony (based on the withdrawn ITU-T Recommendation G.162) .....		59
A.1	General.....	59
A.2	Characteristics of compandors .....	59
A.3	Definition and value of the unaffected level .....	59
A.4	Ratio of compression and expansion.....	59
A.5	Range of level.....	60
A.6	Signal to noise ratio .....	60
Annex B (informative) APLC communication model.....		61
B.1	General.....	61
B.2	AM-SSB modulation technique.....	64
B.3	Functional blocks of an APLC terminal.....	65
Annex C (informative) HF modulated power signal .....		67
C.1	General.....	67
C.2	Discrete tone signals .....	67
C.3	Voice channels .....	69
C.4	Composite channels.....	70
C.5	Calculation examples .....	72
C.5.1	General .....	72
C.5.2	Calculation example 1: Load capacity and PEP .....	72
C.5.3	Calculation example 2: Power distribution adjustment.....	72
Bibliography.....		74
Figure 1 – Schematic representation of the scope of IEC 62488-2 .....		10
Figure 2 – Generic architecture of an APLC terminal.....		16
Figure 3 – Subscriber PBX interfaces local and remote.....		18
Figure 4 – Interfaces for PBX trunk interconnection through APLC link .....		18
Figure 5 – Low symbol rate ITU-T telegraphic channelling .....		19
Figure 6 – Commonly used EIA RS-232 connector.....		22
Figure 7 – Commonly used V.11 connector.....		22
Figure 8 – ETH IEEE 802.3 RJ45 type connector .....		24
Figure 9 – ETH IEEE 802.3 SC type connector .....		24
Figure 10 – Tapping loss limits for APLC terminals .....		26
Figure 11 – Maximum level of spurious emissions outside the high frequency band .....		27
Figure 12 – Reference points for measuring APLC parameters .....		28
Figure 13 – Attenuation distortion limits for the voice frequency band of 300 Hz to 3400 Hz (ITU-T G.232) .....		29
Figure 14 – Attenuation distortion limits for the voice frequency band of 300 Hz to 2400 Hz .....		29
Figure 15 – Attenuation distortion limits for the voice frequency band of 300 Hz to 2000 Hz .....		29

Figure 16 – Group delay distortion limits for the voice frequency band of 300 Hz to 3400 Hz .....	30
Figure 17 – Group delay distortion limits for the voice frequency band of 300 Hz to 2400 Hz .....	30
Figure 18 – Group delay distortion limits for the voice frequency band of 300 Hz to 2000 Hz .....	31
Figure 19 – Test circuit for return loss measurement.....	33
Figure 20 – Test circuit for LCL measurement (Tx port) .....	34
Figure 21 – Test circuit for OSB measurement (Rx port) .....	35
Figure 22 – Test circuit for Tapping Loss measurement .....	35
Figure 23 – Test circuit for selectivity measurement.....	37
Figure 24 – LF disturbances measurement setup .....	54
Figure B.1 – Basic components of the APLC Terminal .....	61
Figure B.2 – Baseband and pass band signals correspondence in SSB modulation .....	61
Figure B.3 – APLC Terminal LF, baseband and HF interfaces identification .....	62
Figure B.4 – Examples for low frequency signals with bandwidth 4 kHz (IEC 62488-1).....	62
Figure B.5 – Composition of the modulating baseband for eight telephony channels with signalling APLC terminal (source Japan NC).....	62
Figure B.6 – Line-up limits of circuits for a 4 kHz channel terminal (ITU-T G.120) .....	63
Figure B.7 – Example of HF channelling plan (4 kHz baseband – IEC 62488-1).....	64
Figure B.8 – Principle of phasing SSB modulator .....	64
Figure B.9 – Principle of phasing SSB demodulator .....	65
Figure B.10 – Generic APLC terminal main functional blocks .....	66
Figure C.1 – Sine wave and its probability distribution .....	68
Figure C.2 – Probability of combined sine waves .....	69
Figure C.3 – Nominal high frequency band output power of multichannel PLC terminals.....	70
Table 1 – FSK symbol rate and related narrowband standards.....	23
Table 2 – Basic insulation [Table C.6 of IEC 60255-27:2013] .....	40
Table 3 – Double or reinforced insulation [Table C.10 of IEC 60255-27:2013] .....	40
Table 4 – List of Type and Routine Tests [Table 12 of IEC 60255-27:2013] .....	42
Table 5 – Classification of climatic conditions [Table 1 of IEC 60721-3-1:1997] .....	43
Table 6 – Climatic tests for storage and transportation.....	44
Table 7 – Classification of climatic conditions from Table 1 of IEC 60721-3-3:2002 .....	46
Table 8 – Classification of mechanical conditions from Table 6 of IEC 60721-3-3:2002.....	47
Table 9 – Climatic tests .....	47
Table 10 – Sinusoidal vibration test .....	48
Table 11 – Non-repetitive shock test .....	48
Table 12 – Emission – Enclosure port [Table 1 of IEC 61000-6-4:2011 (ed.2.1)] .....	50
Table 13 – Emission – Low voltage AC mains port [Table 2 of IEC 61000-6-4:2011 (ed.2.1)].....	52
Table 14 – Emission – Telecommunications/network port [Table 3 of IEC 61000-6-4:2011 (ed.2.1)] .....	53
Table 15 – Characterization of the electromagnetic phenomena [Table 1 of IEC 61000-6-5:2015] .....	55

Table 16 – Port classification .....	56
Table 17 – Performance criteria .....	56
Table 18 – Immunity test list .....	57
Table C.1 – Load capacity of voice channels .....	71

Currently in preview, click buy full version

## INTERNATIONAL ELECTROTECHNICAL COMMISSION

**POWER LINE COMMUNICATION SYSTEMS  
FOR POWER UTILITY APPLICATIONS –**

**Part 2: Analogue power line carrier terminals or APLC**

**FOREWORD**

- 1) The International Electrotechnical Commission (IEC) is a worldwide organization for standardization comprising all national electrotechnical committees (IEC National Committees). The object of IEC is to promote international co-operation on all questions concerning standardization in the electrical and electronic fields. To this end and in addition to other activities, IEC publishes International Standards, Technical Specifications, Technical Reports, Publicly Available Specifications (PAS) and Guides (hereafter referred to as "IEC Publication(s)"). Their preparation is entrusted to technical committees; any IEC National Committee interested in the subject dealt with may participate in this preparatory work. International, governmental and non-governmental organizations liaising with the IEC also participate in this preparation. IEC collaborates closely with the International Organization for Standardization (ISO) in accordance with conditions determined by agreement between the two organizations.
- 2) The formal decisions or agreements of IEC on technical matters express, as nearly as possible, an international consensus of opinion on the relevant subjects since each technical committee has representation from all interested IEC National Committees.
- 3) IEC Publications have the form of recommendations for international use and are accepted by IEC National Committees in that sense. While all reasonable efforts are made to ensure that the technical content of IEC Publications is accurate, IEC cannot be held responsible for the way in which they are used or for any misinterpretation by any end user.
- 4) In order to promote international uniformity, IEC National Committees undertake to apply IEC Publications transparently to the maximum extent possible in their national and regional publications. Any divergence between any IEC Publication and the corresponding national or regional publication shall be clearly indicated in the latter.
- 5) IEC itself does not provide any attestation of conformity. Independent certification bodies provide conformity assessment services and, in some areas, accept IEC marks of conformity. IEC is not responsible for any services carried out by independent certification bodies.
- 6) All users should ensure that they have the latest edition of this publication.
- 7) No liability shall attach to IEC or its directors, employees, servants or agents including individual experts and members of its technical committees and IEC National Committees for any personal injury, property damage or other damage of any nature whatsoever, whether direct or indirect, or for costs (including legal fees) and expenses arising out of the publication, use of, or reliance upon, this IEC Publication or any other IEC Publications.
- 8) Attention is drawn to the normative references cited in this publication. Use of the referenced publications is indispensable for the correct application of this publication.
- 9) Attention is drawn to the possibility that some of the elements of this IEC Publication may be the subject of patent rights. IEC shall not be held responsible for identifying any or all such patent rights.

International Standard IEC 62488-2 has been prepared by IEC technical committee 57: Power systems management and associated information exchange.

This third edition of IEC 62488-2 cancels and replaces the relevant parts of IEC 60663 and IEC 60495, which will be withdrawn at a later date.

This standard is to be used in conjunction with IEC 62488-1.

The text of this International Standard is based on the following documents:

FDIS	Report on voting
57/1867/FDIS	57/1891/RVD

Full information on the voting for the approval of this International Standard can be found in the report on voting indicated in the above table.

This document has been drafted in accordance with the ISO/IEC Directives, Part 2.

A list of all the parts in the IEC 62488 series, published under the general title *Power line communication systems for power utility applications*, can be found on the IEC website.

The committee has decided that the contents of this document will remain unchanged until the stability date indicated on the IEC website under "<http://webstore.iec.ch>" in the data related to the specific document. At this date, the document will be

- reconfirmed,
- withdrawn,
- replaced by a revised edition, or
- amended.

A bilingual version of this publication may be issued at a later date.

**IMPORTANT – The 'colour inside' logo on the cover page of this publication indicates that it contains colours which are considered to be useful for the correct understanding of its contents. Users should therefore print this document using a colour printer.**

## INTRODUCTION

IEC 62488 series is a family of standards dealing with all aspects of power line communication systems operating over electricity power lines.

These international standards apply to power line carrier terminals and systems (PLC) used to transmit information over power networks including extra high, high and medium voltage (EHV/HV/MV) power lines. Both analogue and digital modulation as well as narrow and broadband systems will be included.

The complexity and extensive size of present-day electricity generation, transmission and distribution systems are such that it is possible to control them only by means of an associated and often equally large and complex telecommunication system having a high order of reliability.

The control of electrical networks and transmission and reception of data are through a combination of analogue and digital communication systems controlling devices and systems distributed throughout the electrical network.

The emergence of digital communication systems for controlling the devices of the electrical distribution network enables faster data transmission. The traditional analogue communication systems mainly due to legacy applications are still extensively used.

The ability to represent the various electrical parameters as an analogue signal and/or a digital signal ensures the quality and quantitative aspects of seamless communication to be maintained throughout the electrical power network.

Therefore, by using either analogue power line communication, digital power line communication or a combination of both types of systems, seamless efficient communication may be maintained throughout the power network.

In many countries, Power Line Carrier (PLC) channels represent a main part of the utility-owned telecommunication system. A circuit which would normally be routed via a PLC channel can also be routed via a channel using a different transmission medium, such as a point to point radio or open-wire circuit. Since, in many cases, automatic switching is used, the actual rerouting, although predetermined, is unpredictable.

It is important, therefore, that the input and output signals and criteria exchanged among all terminal used in the communications system are compatible. This compatibility is also beneficial in creating the ability to interchange and interconnect terminals from different sources.

This document has been prepared to enable compatibility between APLC links from different sources or between APLC links and other transmission medium to be achieved and to define the terminal performance required in APLC networks.

# POWER LINE COMMUNICATION SYSTEMS FOR POWER UTILITY APPLICATIONS –

## Part 2: Analogue power line carrier terminals or APLC

### 1 Scope

This part of IEC 62488 applies to Amplitude Modulation Single Sideband (AM-SSB) Analogue Power Line Carrier (APLC) Terminals and Systems used to transmit information over power lines (EHV/HV/MV).

In particular this document covers basically baseband signals with bandwidths of 4 kHz and 2,5 kHz, or multiples thereof, corresponding to the same high frequency bandwidth/s for single or multi-channel APLC terminals.

Figure 1 shows a schematic representation of the scope of the IEC 62488-2 standard within a complete power line communication system installation.

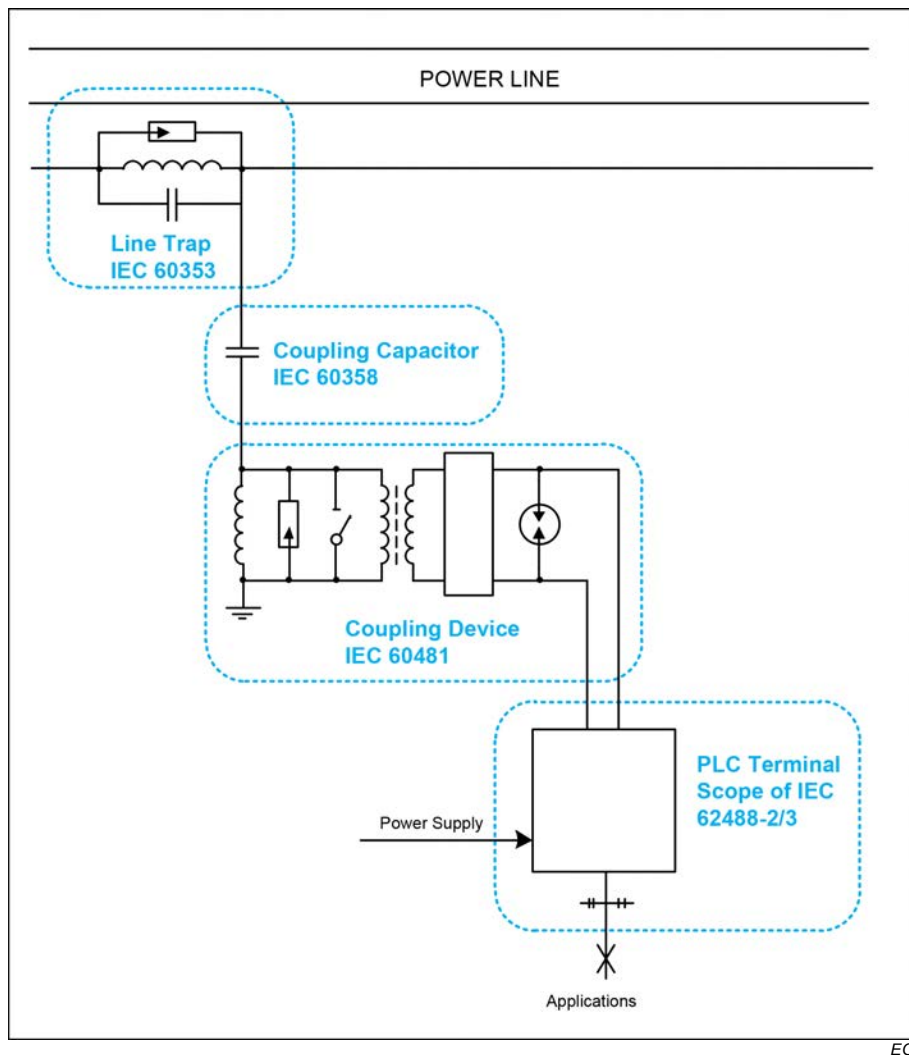

Figure 1 – Schematic representation of the scope of IEC 62488-2