

INTERNATIONAL STANDARD



Railway applications – Compatibility between rolling stock and train detection systems



THIS PUBLICATION IS COPYRIGHT PROTECTED
Copyright © 2024 IEC, Geneva, Switzerland

All rights reserved. Unless otherwise specified, no part of this publication may be reproduced or utilized in any form or by any means, electronic or mechanical, including photocopying and microfilm, without permission in writing from either IEC or IEC's member National Committee in the country of the requester. If you have any questions about IEC copyright or have an enquiry about obtaining additional rights to this publication, please contact the address below or your local IEC member National Committee for further information.

IEC Secretariat
3, rue de Varembe
CH-1211 Geneva 20
Switzerland

Tel.: +41 22 919 02 11
info@iec.ch
www.iec.ch

About the IEC

The International Electrotechnical Commission (IEC) is the leading global organization that prepares and publishes International Standards for all electrical, electronic and related technologies.

About IEC publications

The technical content of IEC publications is kept under constant review by the IEC. Please make sure that you have the latest edition, a corrigendum or an amendment might have been published.

IEC publications search - webstore.iec.ch/advsearchform

The advanced search enables to find IEC publications by a variety of criteria (reference number, text, technical committee, ...). It also gives information on projects, replaced and withdrawn publications.

IEC Just Published - webstore.iec.ch/justpublished

Stay up to date on all new IEC publications. Just Published details all new publications released. Available online and once a month by email.

IEC Customer Service Centre - webstore.iec.ch/csc

If you wish to give us your feedback on this publication or need further assistance, please contact the Customer Service Centre: sales@iec.ch.

IEC Products & Services Portal - products.iec.ch

Discover our powerful search engine and read freely all the publications previews, graphical symbols and the glossary. With a subscription you will always have access to up to date content tailored to your needs.

Electropedia - www.electropedia.org

The world's leading online dictionary on electrotechnology, containing more than 22 500 terminological entries in English and French, with equivalent terms in 25 additional languages. Also known as the International Electrotechnical Vocabulary (IEV) online.



IEC 62427

Edition 2.0 2024-12

INTERNATIONAL STANDARD



Railway applications – Compatibility between rolling stock and train detection systems

INTERNATIONAL
ELECTROTECHNICAL
COMMISSION

ICS 45.060.01

ISBN 978-2-8327-0024-2

Warning! Make sure that you obtained this publication from an authorized distributor.

CONTENTS

| | |
|---|----|
| FOREWORD..... | 5 |
| INTRODUCTION..... | 7 |
| 1 Scope..... | 9 |
| 2 Normative references | 9 |
| 3 Terms, definitions and abbreviated terms | 9 |
| 3.1 Terms and definitions..... | 9 |
| 3.2 Abbreviated terms..... | 10 |
| 4 Compatibility process | 10 |
| 4.1 Overview..... | 11 |
| 4.2 Detailed compatibility process..... | 10 |
| 4.3 Building the compatibility argument..... | 11 |
| 4.4 Quality management | 12 |
| 4.5 Route identification for introduction of RST (new or changed)..... | 12 |
| 4.6 Introduction of infrastructure elements (new or changed)..... | 12 |
| 4.7 Characterization..... | 13 |
| 4.8 Compatibility analyses | 13 |
| 4.8.1 General terms..... | 13 |
| 4.8.2 Transfer function | 14 |
| 5 Characterization of train detection systems | 15 |
| 5.1 Objective of procedure..... | 15 |
| 5.2 Track circuit systems – Standards, regulations and technical specifications | 16 |
| 5.3 Axle counter systems – Standards, regulations and technical specifications | 16 |
| 5.4 Wheel detectors (treadle applications) | 16 |
| 5.4.1 General | 16 |
| 5.4.2 Wheel detectors based on inductive technology..... | 16 |
| 5.5 Loops..... | 17 |
| 5.5.1 General aspects | 17 |
| 5.5.2 Interfering mechanisms..... | 17 |
| 5.5.3 Characterization | 18 |
| 6 Characterization of rolling stock..... | 18 |
| 6.1 Objective | 18 |
| 6.2 General procedure | 18 |
| 7 Characterization of traction power supply systems..... | 19 |
| 7.1 Objective | 19 |
| 7.2 DC traction power supplies | 19 |
| 7.3 AC traction power supplies | 19 |
| 7.4 Test procedures | 20 |
| 8 Test report..... | 20 |
| 8.1 General..... | 20 |
| 8.2 Introduction to the report..... | 20 |
| 8.3 Test organization | 20 |
| 8.4 Configuration | 20 |
| 8.5 Reference documents | 20 |
| 8.6 Application of the test plan..... | 21 |
| 8.7 Test results | 21 |
| 8.8 Comments | 21 |

| | | |
|---|--|----|
| 8.9 | Archive of test results | 21 |
| Annex A (informative) Guidelines for the determination of susceptibility of train detection systems | | |
| | | 22 |
| A.1 | Examples of system configurations | 22 |
| A.2 | "Normal" configuration | 22 |
| A.3 | Interference mechanism with broken signal rail | 22 |
| A.4 | Interference mechanism with broken return rail | 23 |
| A.5 | Double rail track circuits | 24 |
| A.6 | Voltage between axles of rolling stock | 25 |
| A.7 | Effect of resistance between coupled vehicles | 26 |
| A.8 | Radiated interference | 28 |
| A.9 | Sensitive zone of wheel detector | 28 |
| A.10 | Factor of safety | 29 |
| A.11 | Multiple interference sources | 29 |
| Annex B (informative) General characterization of rolling stock | | |
| | | 30 |
| B.1 | Objective of procedure | 30 |
| B.2 | Description of rolling stock and factors affecting its characteristics | 30 |
| B.3 | Configuration (design status) | 30 |
| B.4 | Test plan | 30 |
| B.4.1 | General | 30 |
| B.4.2 | Test site | 31 |
| B.4.3 | Instrumentation | 31 |
| B.4.4 | Test procedure | 31 |
| Annex C (informative) Factors affecting rolling stock characteristics and compatibility | | |
| | | 33 |
| Annex D (informative) DC traction power supplies | | |
| | | 36 |
| D.1 | General | 36 |
| D.2 | Interference currents generated by the rolling stock | 36 |
| D.3 | Interference currents generated by the traction power supply system | 36 |
| Annex E (informative) Compatibility parameters for loops (European example) | | |
| | | 39 |
| E.1 | General | 39 |
| E.2 | Principles of operation – Electrical background | 39 |
| E.3 | Vehicle metal construction | 39 |
| Bibliography | | |
| | | 42 |
| Figure 1 – Sources of electromagnetic interference | | |
| | | 7 |
| Figure 2 – The compatibility process | | |
| | | 11 |
| Figure 3 – Relationship between compatibility limits and permissible interference | | |
| | | 15 |
| Figure A.1 – Interference mechanism with rails intact | | |
| | | 22 |
| Figure A.2 – Interference mechanism with self-revealing broken rail | | |
| | | 23 |
| Figure A.3 – Interference mechanism with unrevealed broken rail | | |
| | | 23 |
| Figure A.4 – Double rail track circuit | | |
| | | 24 |
| Figure A.5 – Double rail track circuit with broken rail | | |
| | | 24 |
| Figure A.6 – Interference mechanism due to voltage between axles – Case 1 | | |
| | | 25 |
| Figure A.7 – Interference mechanism due to voltage between axles – Case 2 | | |
| | | 25 |
| Figure A.8 – Effect of inter-vehicle current | | |
| | | 26 |
| Figure A.9 – Equivalent circuit for Figure A.8 | | |
| | | 26 |
| Figure A.10 – Example of radiated interference | | |
| | | 28 |

| | |
|---|----|
| Figure C.1 – Electrical bonding | 34 |
| Figure D.1 – Rolling stock with DC supply..... | 37 |
| Figure D.2 – Circulation of interference current generated by rolling stock..... | 37 |
| Figure D.3 – Circulation of interference current generated by the substation..... | 38 |
| Figure E.1 – Example of loop installation | 39 |
| Figure E.2 – Vehicle layouts | 40 |
| Figure E.3 – Example longitudinal beams with cross connection in section (a)..... | 40 |
| Figure E.4 – Example short circuit rings in section (a)..... | 40 |

Currently in preview, click buy full version

INTERNATIONAL ELECTROTECHNICAL COMMISSION

**RAILWAY APPLICATIONS –
COMPATIBILITY BETWEEN ROLLING STOCK
AND TRAIN DETECTION SYSTEMS**

FOREWORD

- 1) The International Electrotechnical Commission (IEC) is a worldwide organization for standardization comprising all national electrotechnical committees (IEC National Committees). The object of IEC is to promote international co-operation on all questions concerning standardization in the electrical and electronic fields. To this end and in addition to other activities, IEC publishes International Standards, Technical Specifications, Technical Reports, Publicly Available Specifications (PAS) and Guides (hereafter referred to as "IEC Publication(s)"). Their preparation is entrusted to technical committees; any IEC National Committee interested in the subject dealt with may participate in this preparatory work. International, governmental and non-governmental organizations liaising with the IEC also participate in this preparation. IEC collaborates closely with the International Organization for Standardization (ISO) in accordance with conditions determined by agreement between the two organizations.
- 2) The formal decisions or agreements of IEC on technical matters express, as nearly as possible, an international consensus of opinion on the relevant subjects since each technical committee has representation from all interested IEC National Committees.
- 3) IEC Publications have the form of recommendations for international use and are accepted by IEC National Committees in that sense. While all reasonable efforts are made to ensure that the technical content of IEC Publications is accurate, IEC cannot be held responsible for the way in which they are used or for any misinterpretation by any end user.
- 4) In order to promote international uniformity, IEC National Committees undertake to apply IEC Publications transparently to the maximum extent possible in their national and regional publications. Any divergence between any IEC Publication and the corresponding national or regional publication shall be clearly indicated in the latter.
- 5) IEC itself does not provide any attestation of conformity. Independent certification bodies provide conformity assessment services and, in some areas, access to IEC marks of conformity. IEC is not responsible for any services carried out by independent certification bodies.
- 6) All users should ensure that they have the latest edition of this publication.
- 7) No liability shall attach to IEC or its directors, employees, servants or agents including individual experts and members of its technical committees and IEC National Committees for any personal injury, property damage or other damage of any nature whatsoever whether direct or indirect, or for costs (including legal fees) and expenses arising out of the publication, use of, or reliance upon, this IEC Publication or any other IEC Publications.
- 8) Attention is drawn to the Normative references cited in this publication. Use of the referenced publications is indispensable for the correct application of this publication.
- 9) IEC draws attention to the possibility that the implementation of this document may involve the use of (a) patent(s). IEC takes no position concerning the evidence, validity or applicability of any claimed patent rights in respect thereof. As of the date of publication of this document, IEC had not received notice of (a) patent(s), which may be required to implement this document. However, implementers are cautioned that this may not represent the latest information, which may be obtained from the patent database available at <https://patents.iec.ch>. IEC shall not be held responsible for identifying any or all such patent rights.

IEC 62427 has been prepared by IEC technical committee 9: Electrical equipment and systems for railways. It is an International Standard.

This document is based on EN 50238-1:2019.

This second edition cancels and replaces the first edition published in 2007. This edition constitutes a technical revision.

This edition includes the following significant technical changes with respect to the previous edition:

- a) generic compatibility process, which is broken into a two-stage process depending on whether there are established compatibility limits or not;
- b) rules for characterization of train detection systems;

- c) rules for characterization of rolling stock;
- d) rules for characterization of the power system;
- e) informative references are provided in notes to established CENELEC standards for compatibility;
- f) terminology is updated.

The text of this International Standard is based on the following documents:

| Draft | Report on voting |
|-------------|------------------|
| 9/3115/FDIS | 9/3142A/RVD |

Full information on the voting for its approval can be found in the report on voting indicated in the above table.

The language used for the development of this International Standard is English.

This document was drafted in accordance with ISO/IEC Directives, Part 2 and developed in accordance with ISO/IEC Directives, Part 1 and ISO/IEC Directives, IEC Supplement, available at www.iec.ch/members_experts/refdocs. The main document types developed by IEC are described in greater detail at www.iec.ch/publications.

The committee has decided that the contents of this document will remain unchanged until the stability date indicated on the IEC website under webstore.iec.ch in the data related to the specific document. At this date, the document will be

- reconfirmed,
- withdrawn, or
- revised.

IMPORTANT – The "colour inside" logo on the cover page of this document indicates that it contains colours which are considered to be useful for the correct understanding of its contents. Users should therefore print this document using a colour printer.

INTRODUCTION

This document defines a process to demonstrate compatibility between rolling stock operating on an area of use or network and train detection systems installed in this area of use or network.

Currently, general rules for the maximum levels of interference allowed, and maximum susceptibility levels (or minimum required immunity levels) are not established in every country. This is due to the great diversity of rolling stock, power supply and return current systems, and train detection systems installed in each country. This diversity leads to consideration of compatibility of rolling stock and train detection systems on a "route by route" or "network by network" basis, to avoid unnecessarily restrictive specifications.

The compatibility process described in this document is generic. The process refers to all types of train detection systems (TDS), which may be influenced by electromagnetic emissions of rolling stock or traction power supply systems, (e.g. axle counters, track circuits, wheel detectors, loops).

Compatibility is determined by both physical and electromagnetic considerations. With regard to the electromagnetic compatibility, the need is not for general values for maximum levels of interference permitted, and maximum susceptibility levels (or minimum required immunity levels) but for convenient methods by which to specify the level of interference allowed for operation on routes or a network.

Main interference sources are considered to be:

- rail currents and voltage sources;
- electromagnetic fields;
- differential voltage between adjacent axles of the train;

as shown in Figure 1.

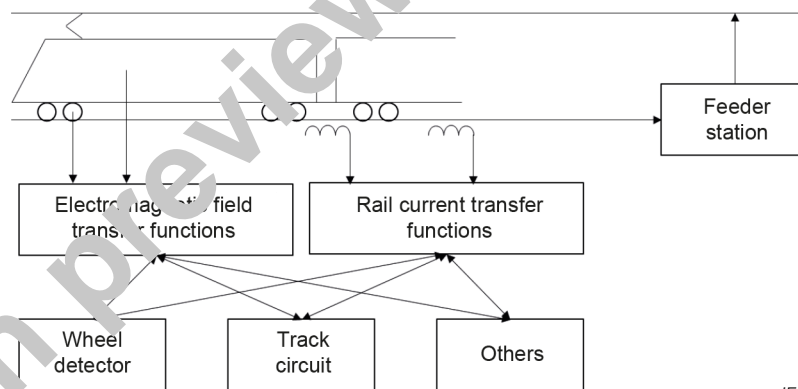

Figure 1 – Sources of electromagnetic interference

In practice, the susceptibility of the system is determined by:

- the sensitivity of individual components of the system and the type of interference it is susceptible to;
- the application of the components, i.e. the configuration of the system.

Therefore the problems concerning TDS are considered separately for each type.

- National rules or standards, including agreements among stakeholders, define compatibility limits for track circuits;
- National rules or standards, including agreements among stakeholders, define compatibility limits for axle counters and wheel detectors;
- National rules or standards, including agreements among stakeholders, define the testing method of rolling stock for electromagnetic compatibility with axle counters;
- Compatibility with other types of wheel detectors (mechanical or magnetic) is described in 5.4;
- Compatibility with loops can be established following the guidance in 5.5;
- Compatibility with any other type of TDS not explicitly covered by this document can also be established following the generic process in this document.

NOTE 1 In Europe, CLC/TS 50238-2, CLC/TS 50238-3 and EN 50592 provide compatibility limits for track circuits, compatibility limits for axle counters and wheel detectors, and the testing method of rolling stock for electromagnetic compatibility with axle counters, respectively.

For determining the susceptibility of signalling systems, laboratory/simulation testing methods and in situ tests on the "real railway" are proposed. Modelling enables worst case conditions to be simulated. In addition, particular test sites are selected because from experience, they are expected to provide the test evidence required.

Then, taking account of the experience of the railways, it is possible to establish a general method for determining the susceptibility of train detection systems, described in this document.

NOTE 2 In Europe, general requirements on how to establish immunity have been defined in EN 50617-1 and EN 50617-2.

Before assessing the electromagnetic emissions of rolling stock, sufficient knowledge of the electric circuit diagram of the power equipment is important, including switching frequencies of on-board power converters, type of regulation used for power converters, resonant frequency of each filter, operating limits under high and low supply voltages, degraded modes of operation.

RAILWAY APPLICATIONS – COMPATIBILITY BETWEEN ROLLING STOCK AND TRAIN DETECTION SYSTEMS

1 Scope

This document describes a process to demonstrate compatibility between rolling stock (RST) and train detection systems (TDS). It describes the characterization of train detection systems, rolling stock and traction power supply systems.

It is worth noting that the demonstration of technical compatibility between the rolling stock and infrastructure with respect to physical dimensions is not detailed in this document.

This document is not generally applicable to those combinations of rolling stock, traction power supply and train detection system which were accepted as compatible prior to the publication of this document. However, as far as is reasonably practicable, this document can be applied to modifications of rolling stock, traction power supply or train detection systems which can affect compatibility. The detailed process can be used where no rules and processes for compatibility are established.

2 Normative references

There are no normative references in this document.

3 Terms, definitions and abbreviated terms

3.1 Terms and definitions

For the purposes of this document, the following terms and definitions apply.

ISO and IEC maintain terminology databases for use in standardization at the following addresses:

- IEC Electropedia: available at <https://www.electropedia.org/>
- ISO Online browsing platform: available at <https://www.iso.org/obp>

3.1.1

competent body

body responsible for the independent evaluation of the compatibility case

Note 1 to entry: This can be an accredited conformity body or an independent safety assessor. This role is not limited to external parties, unless mandated under the applicable legislation.

3.1.2

compatibility case

set of documents which records the evidence demonstrating the degree of compatibility between rolling stock, traction power supplies and train detection systems for a specific route or specific railway network

[SOURCE: IEC 60050-821:2017, 821-03-47]