



IEC 61968-13

Edition 1.0 2008-06

INTERNATIONAL STANDARD

**Application integration at electric utilities – System interfaces for distribution management –
Part 13: CIM RDF Model exchange format for distribution**

INTERNATIONAL
ELECTROTECHNICAL
COMMISSION

PRICE CODE **XA**

ICS 33.200

ISBN 2-8318-9873-0

CONTENTS

FOREWORD.....	4
INTRODUCTION.....	6
1 Scope.....	7
2 Normative references.....	8
3 Future standards documents related to this part.....	9
4 CIM RDF describing distribution networks.....	9
5 Issues related to partial-phase devices modeling.....	10
5.1 General.....	10
5.2 Impedances of unbalanced and partial phase devices.....	10
5.3 Switches.....	10
5.4 Partial phase continuity in radial networks.....	10
6 CIM classes used and corresponding RDF.....	11
6.1 General.....	11
6.2 BaseVoltage and VoltageLevel.....	11
6.3 Containment hierarchy roots.....	12
6.4 HV/MV substation.....	12
6.5 MV/MV substation.....	12
6.6 MV/LV substation.....	13
6.7 Junction.....	13
6.8 Switch.....	14
6.9 Bay.....	14
6.10 BusbarSection.....	15
6.11 PowerTransformer.....	16
6.12 MV/MV transformer.....	17
6.13 Line.....	17
6.14 ACLineSegment.....	19
6.15 WireArrangement.....	19
6.16 Compensator.....	21
6.17 StaticVarCompensator.....	21
6.18 EquivalentLoad.....	22
6.19 Using CustomLoad, GeneratingUnit and SynchronousMachine to model Distributed Energy Resource.....	23
6.20 GeneratingUnit.....	24
6.21 SynchronousMachine.....	24
6.22 HostControlArea.....	25
6.23 SubControlArea.....	25
6.24 Adequation between IEC 61968-3 (CDPSM) and IEC 61968-4.....	25
6.25 Adequation between CDPSM and CPSM.....	26
Annex A (informative) CIM XML Document from Langdale.....	27
Annex B (informative) Comparison between CIM RDF and CIM XSD (ISO ITC Working Group Architecture).....	30
Annex C (informative) Key discussion points on CIM RDF and CIM XSD (ISO ITC Working Group Architecture).....	32
Annex D (informative) Conclusions and recommendations (ISO ITC Working Group Architecture).....	33

Annex E (informative) Example of a European distribution network described through CIM RDF.....	34
Annex F (informative) Example of a North American distribution network.....	42
Annex G (informative) Comparison between CDPSM and CPSM.....	44
Bibliography.....	58
Figure 1 – XML-based DMS network data configuration.....	8
Figure 2 – Connectivity of BusbarSection.....	15
Figure E.1 – European distribution network example.....	35
Figure F.1 – North American distribution network example.....	43
Table 1 – Header of NetworkDataSet message type.....	25
Table 2 – Message Payload of NetworkDataSet message type.....	26

INTERNATIONAL ELECTROTECHNICAL COMMISSION

**APPLICATION INTEGRATION AT ELECTRIC UTILITIES –
SYSTEM INTERFACES FOR DISTRIBUTION MANAGEMENT –**

Part 13: CIM RDF Model exchange format for distribution

FOREWORD

- 1) The International Electrotechnical Commission (IEC) is a worldwide organization for standardization comprising all national electrotechnical committees (IEC National Committees). The object of IEC is to promote international co-operation on all questions concerning standardization in the electrical and electronic fields. To this end and in addition to other activities, IEC publishes International Standards, Technical Specifications, Technical Reports, Publicly Available Specifications (PAS) and Guides (hereafter referred to as "IEC Publication(s)"). Their preparation is entrusted to technical committees; any IEC National Committee interested in the subject dealt with may participate in this preparatory work. International, governmental and non-governmental organizations liaising with the IEC also participate in this preparation. IEC collaborates closely with the International Organization for Standardization (ISO) in accordance with conditions determined by agreement between the two organizations.
- 2) The formal decisions or agreements of IEC on technical matters express, as far as possible, an international consensus of opinion on the relevant subjects since each technical committee has representation from all interested IEC National Committees.
- 3) IEC Publications have the form of recommendations for international use and are accepted by IEC National Committees in that sense. While all reasonable efforts are made to ensure that the technical content of IEC Publications is accurate, IEC cannot be held responsible for the way in which they are used or for any misinterpretation by any end user.
- 4) In order to promote international uniformity, IEC National Committees undertake to apply IEC Publications transparently to the maximum extent possible in their national and regional publications. Any divergence between any IEC Publication and the corresponding national or regional publication shall be clearly indicated in the latter.
- 5) IEC provides no marking procedure to indicate its approval and cannot be rendered responsible for any equipment declared to be in conformity with an IEC Publication.
- 6) All users should ensure that they have the latest edition of this publication.
- 7) No liability shall attach to IEC or its directors, employees, servants or agents including individual experts and members of its technical committees and IEC National Committees for any personal injury, property damage or other damage of any nature whatsoever, whether direct or indirect, or for costs (including legal fees) and expenses arising out of the publication, use of, or reliance upon, this IEC Publication or any other IEC Publications.
- 8) Attention is drawn to the Normative references cited in this publication. Use of the referenced publications is indispensable for the correct application of this publication.
- 9) Attention is drawn to the possibility that some of the elements of this IEC Publication may be the subject of patent rights. IEC shall not be held responsible for identifying any or all such patent rights.

International Standard IEC 61968-13 has been prepared by IEC technical committee 57: Power system management and associated information exchange.

The text of this standard is based on the following documents:

FDIS	Report on Voting
57/930/FDIS	57/955/RVD

Full information on the voting for the approval of this standard can be found in the report on voting indicated in the above table.

A list of all parts of the IEC 61968 series, under the general title *Application integration at electric utilities – System interfaces for distribution management*, can be found on the IEC website.

The committee has decided that the contents of this publication will remain unchanged until the maintenance result date indicated on the IEC web site under "<http://webstore.iec.ch>" in the data related to the specific publication. At this date, the publication will be

- reconfirmed;
- withdrawn;
- replaced by a revised edition, or
- amended.

A bilingual version of this publication may be issued at a later date.

Currently in preview, click buy full vers.

INTRODUCTION

The IEC 61968 series of standards is intended to facilitate inter-application integration as opposed to intra-application integration. Intra-application integration is aimed at programs in the same application system, usually communicating with each other using middleware that is embedded in their underlying runtime environment, and tends to be optimized for close, real-time, synchronous connections and interactive request/reply or conversation communication models. IEC 61968, by contrast, is intended to support the inter-application integration of a utility enterprise that needs to connect disparate applications that are already built or new (legacy or purchased applications), each supported by dissimilar runtime environments. Therefore, these interface standards are relevant to loosely coupled applications with more heterogeneity in languages, operating systems, protocols and management tools. This series of standards is intended to support applications that need to exchange data every few seconds, minutes, or hours rather than waiting for a nightly batch run. This series of standards, which are intended to be implemented with middleware services that exchange messages among applications, will complement, not replace utility data warehouses, database gateways, and operational stores.

As used in IEC 61968, a DMS consists of various distributed application components for the utility to manage electrical distribution networks. These capabilities include monitoring and control of equipment for power delivery, management processes to ensure system reliability, voltage management, demand-side management, outage management, work management, automated mapping and facilities management. Standards interfaces are defined for each class of applications identified in the Interface Reference Model (IRM), which is described in IEC 61968-1.

APPLICATION INTEGRATION AT ELECTRIC UTILITIES – SYSTEM INTERFACES FOR DISTRIBUTION MANAGEMENT –

Part 13: CIM RDF Model exchange format for distribution

1 Scope

This part of IEC 61968 specifies the format and rules for exchanging modeling information based upon the CIM (Common Information Model) and related to distribution network data.

The intention of this part of IEC 61968 is to allow the exchange of instance data in bulk. Thus, the imported network model data should be sufficient to allow performing network connectivity analysis, including network tracing, outage analysis, load flow calculations, etc. This part could be used for synchronizing geographical information system databases with remote control system databases.

This part is closely linked to IEC 61970-452 Energy Management System Application Program Interface (EMS-API) CIM Network applications model exchange specification. Thus, this document has been written in order to reduce its maintenance. It describes only differences with IEC 61970-452. Nevertheless, as IEC 61970-452 is a full international standard, this part still has duplicate information with IEC 61970-452, in order to be more understandable.

It uses the CIM RDF¹⁾ Schema presented in IEC 61970-501 as the meta-model framework for constructing XML²⁾ documents containing power system modeling information. The syntax of these documents is called CIM XML format. Model exchange by file transfer serves many useful purposes, specially when some applications need to have the complete network model defined. Though the format can be used for general CIM-based information exchange, in this part of IEC 61968, specific profiles (or subsets) of the CIM are identified in order to address particular exchange requirements.

Given the CIM RDF Schema described in IEC 61970-501, a DMS power system model can be converted for export as an XML document, see Figure 1. This document is referred to as a CIM XML document. All of the tags (resource descriptions) used in the CIM XML document are supplied by the CIM RDF Schema. The resulting CIM XML model exchange document can be parsed and the information imported into a foreign system. This part of IEC 61968 is aligned to CIM Model version 11, CPSM 3.0 profile.

1) RDF: Resource Description Framework.

2) XML: eXtensible Markup Language.

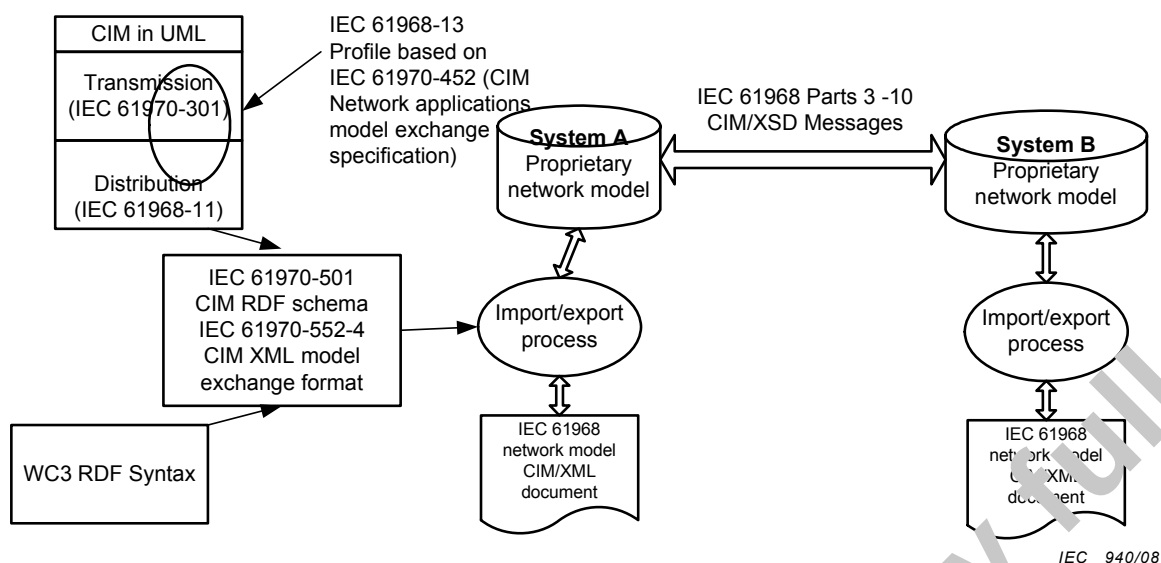

Figure 1 – XML-based DMS network data configuration.

Similar to using any programming language, implementers have many choices when creating a CIM XML document. The RDF syntax itself can be used in several ways to achieve the same basic result. The way one approaches the CIM RDF Schema can yield various forms when producing a CIM XML document. The following clauses discuss the style guidelines for producing a CIM XML document. Such guideline rules are important to communicate and follow when producing these documents because they simplify and facilitate the software written to unambiguously interpret the model information.

Some comparisons have been made between CIM RDF and CIM XSD. Annexes A, B, C and D are extracted from articles and documents discussing CIM RDF and CIM XSD. A distribution management system can use only a CIM XSD message types architecture, but CIM RDF has three advantages:

- A UML model is a graph model and RDF helps to describe the graph model. XSD describes a hierarchical model which suits the message type approach.
- RDF is more readable and understandable by people working in the electrotechnical field.
- It is a basic requirement to build ontologies.

If required, tools would ensure the compatibility between CIM-RDF and, for instance, IEC 61968-4 and IEC 61968-3 message types concerning distribution network model representation.

2 Normative references

The following referenced documents are indispensable for the application of this document. For dated references, only the edition cited applies. For undated references, the latest edition of the referenced document (including any amendments) applies.

IEC 61968-1, *Application integration at electric utilities – System interfaces for distribution management – Part 1: Interface architecture and general requirements*

IEC 61968-3, *Application integration at electric utilities – System interfaces for distribution management – Part 3: Interface for network operations*

IEC 61968-4, *Application integration at electric utilities – System interfaces for distribution management – Part 4: Interfaces for records and asset management*

IEC 61970-301, *Energy management system application program interface (EMS-API) – Part 301: Common Information Model (CIM) base*

IEC 61970-501, *Energy management system application program interface (EMS-API) – Part 501: Common Information Model Resource Description Framework (CIM RDF) schema*