



THIS PUBLICATION IS COPYRIGHT PROTECTED

Copyright © 2017 IEC, Geneva, Switzerland

All rights reserved. Unless otherwise specified, no part of this publication may be reproduced or utilized in any form or by any means, electronic or mechanical, including photocopying and microfilm, without permission in writing from either IEC or IEC's member National Committee in the country of the requester. If you have any questions about IEC copyright or have an enquiry about obtaining additional rights to this publication, please contact the address below or your local IEC member National Committee for further information.

Droits de reproduction réservés. Sauf indication contraire, aucune partie de cette publication ne peut être reproduite ni utilisée sous quelque forme que ce soit et par aucun procédé, électronique ou mécanique, y compris la photocopie et les microfilms, sans l'accord écrit de l'IEC ou du Comité national de l'IEC du pays du demandeur. Si vous avez des questions sur le copyright de l'IEC ou si vous désirez obtenir des droits supplémentaires sur cette publication, utilisez les coordonnées ci-après ou contactez le Comité national de l'IEC de votre pays de résidence.

IEC Central Office
3, rue de Varembe
CH-1211 Geneva 20
Switzerland

Tel.: +41 22 919 02 11
info@iec.ch
www.iec.ch

About the IEC

The International Electrotechnical Commission (IEC) is the leading global organization that prepares and publishes International Standards for all electrical, electronic and related technologies.

About IEC publications

The technical content of IEC publications is kept under constant review by the IEC. Please make sure that you have the latest edition, a corrigendum or an amendment might have been published.

IEC publications search - webstore.iec.ch/advsearchform

The advanced search enables to find IEC publications by a variety of criteria (reference number, text, technical committee,...). It also gives information on projects, replaced and withdrawn publications.

IEC Just Published - webstore.iec.ch/justpublished

Stay up to date on all new IEC publications. Just Published details all new publications released. Available online and once a month by email.

IEC Customer Service Centre - webstore.iec.ch/csc

If you wish to give us your feedback on this publication or need further assistance, please contact the Customer Service Centre: sales@iec.ch.

Electropedia - www.electropedia.org

The world's leading online dictionary on electrotechnology, containing more than 22 000 terminological entries in English and French, with equivalent terms in 16 additional languages. Also known as the International Electrotechnical Vocabulary (IEV) online.

IEC Glossary - std.iec.ch/glossary

67 000 electrotechnical terminology entries in English and French extracted from the Terms and Definitions clause of IEC publications issued since 2002. Some entries have been collected from earlier publications of IEC TC 37, 77, 86 and CISPR.

A propos de l'IEC

La Commission Electrotechnique Internationale (IEC) est la première organisation mondiale qui élabore et publie des Normes internationales pour tout ce qui a trait à l'électricité, à l'électronique et aux technologies apparentées.

A propos des publications IEC

Le contenu technique des publications IEC est constamment revu. Veuillez vous assurer que vous possédez l'édition la plus récente, un corrigendum ou amendement peut avoir été publié.

Recherche de publications IEC - webstore.iec.ch/advsearchform

La recherche avancée permet de trouver des publications IEC en utilisant différents critères (numéro de référence, texte, comité d'études,...). Elle donne aussi des informations sur les projets et les publications remplacées ou retirées.

IEC Just Published - webstore.iec.ch/justpublished

Restez informé sur les nouvelles publications IEC. Just Published détaille les nouvelles publications parues. Disponible en ligne et une fois par mois par email.

Service Clients - webstore.iec.ch/csc

Si vous désirez nous donner des commentaires sur cette publication ou si vous avez des questions contactez-nous: sales@iec.ch.

Electropedia - www.electropedia.org

Le premier dictionnaire d'électrotechnologie en ligne au monde, avec plus de 22 000 articles terminologiques en anglais et en français, ainsi que les termes équivalents dans 16 langues additionnelles. Egalement appelé Vocabulaire Electrotechnique International (IEV) en ligne.

Glossaire IEC - std.iec.ch/glossary

67 000 entrées terminologiques électrotechniques, en anglais et en français, extraites des articles Termes et Définitions des publications IEC parues depuis 2002. Plus certaines entrées antérieures extraites des publications des CE 37, 77, 86 et CISPR de l'IEC.

INTERNATIONAL STANDARD

NORME INTERNATIONALE



**Connectors for electrical and electronic equipment – Product requirements –
Part 3-122: Detail specification for 8-way, shielded, free and fixed connectors for
I/O and Gigabit Ethernet applications in harsh environments**

**Connecteurs pour équipements électriques et électroniques – Exigences de
produit –
Partie 3-122: Spécification particulière pour les fiches et les embases écrantées
à 8 voies pour applications E/S et Ethernet Gigabit en environnements sévères**

INTERNATIONAL
ELECTROTECHNICAL
COMMISSION

COMMISSION
ELECTROTECHNIQUE
INTERNATIONALE

ICS 31.220.10

ISBN 978-2-8322-8448-3

**Warning! Make sure that you obtained this publication from an authorized distributor.
Attention! Veuillez vous assurer que vous avez obtenu cette publication via un distributeur agréé.**

CONTENTS

| | |
|---|----|
| FOREWORD..... | 4 |
| 1 Scope..... | 7 |
| 2 Normative references | 7 |
| 3 Terms and definitions | 8 |
| 4 Mating information..... | 9 |
| 4.1 General..... | 9 |
| 4.2 Contacts – mating conditions | 9 |
| 4.3 Fixed connector Type I | 10 |
| 4.4 Free connector Type I..... | 13 |
| 4.5 Fixed connector Type II | 14 |
| 4.6 Free connector Type II..... | 16 |
| 5 Characteristics | 17 |
| 5.1 General..... | 17 |
| 5.2 Pin and pair grouping assignment | 17 |
| 5.3 Classification into climatic category | 18 |
| 5.4 Electrical characteristics | 19 |
| 5.4.1 Voltage proof..... | 19 |
| 5.4.2 Voltage rating | 19 |
| 5.4.3 Current-temperature derating..... | 19 |
| 5.4.4 Initial insulation resistance | 20 |
| 5.5 Mechanical characteristics | 20 |
| 5.5.1 Mechanical operation..... | 20 |
| 5.5.2 Insertion and withdrawal forces | 20 |
| 5.6 Transmission performance | 21 |
| 5.6.1 General | 21 |
| 5.6.2 Insertion loss | 21 |
| 5.6.3 Return loss | 21 |
| 5.6.4 Near end cross talk | 21 |
| 5.6.5 Far end cross talk..... | 21 |
| 5.6.6 Transverse crosstalk conversion loss | 21 |
| 5.6.7 Transverse crosstalk conversion transfer loss..... | 21 |
| 5.6.8 Transfer impedance..... | 22 |
| 6 Tests and test schedule..... | 22 |
| 6.1 General..... | 22 |
| 6.2 Arrangement for contact resistance test (Figure 8)..... | 22 |
| 6.3 Arrangement for vibration test (test phase DP3) (Figure 9)..... | 23 |
| 6.4 Test procedures and measuring methods..... | 23 |
| 6.5 Preconditioning..... | 24 |
| 6.6 Test schedules..... | 24 |
| 6.6.1 General | 24 |
| 6.6.2 Basic (minimum) test schedule | 24 |
| 6.6.3 Full test schedule | 24 |
| 7 Mounting of specimens | 31 |

| | |
|---|----|
| Figure 1 – Contact interface dimensions with a free (male) connector (right side) mated with a fixed (female) connector (left side) | 9 |
| Figure 2 – Fixed female connector Type I | 10 |
| Figure 3 – Free male connector Type I..... | 12 |
| Figure 4 – Fixed (female) connector Type II..... | 14 |
| Figure 5 – Free (male) connector Type II | 16 |
| Figure 6 – Fixed connector pin and pair grouping assignment for Type I (left, with coding edges on one short side) and Type II (right, with coding edges on one long side), front view of connector | 18 |
| Figure 7 – Connector de-rating curve | 20 |
| Figure 8 – Arrangement for contact resistance test | 22 |
| Figure 9 – Arrangement for vibration test | 23 |
| | |
| Table 1 – Dimensions for Figure 1 | 9 |
| Table 2 – Dimensions for Figure 2 | 11 |
| Table 3 – Dimensions for Figure 3 | 13 |
| Table 4 – Dimensions for Figure 4 | 15 |
| Table 5 – Dimensions for Figure 5 | 17 |
| Table 6 – Pin assignment for 10/100 Mb Ethernet | 18 |
| Table 7 – Pin assignment for 1 Gb Ethernet..... | 18 |
| Table 8 – Climatic category..... | 19 |
| Table 9 – Test group P | 25 |
| Table 10 – Test group AP | 25 |
| Table 11 – Test group BP | 27 |
| Table 12 – Test group CP..... | 28 |
| Table 13 – Test group DP | 29 |
| Table 14 – Test group EP | 30 |
| Table 15 – Test group FP | 31 |

INTERNATIONAL ELECTROTECHNICAL COMMISSION

**CONNECTORS FOR ELECTRICAL AND ELECTRONIC EQUIPMENT –
PRODUCT REQUIREMENTS –****Part 3-122: Detail specification for 8-way, shielded, free and fixed
connectors for I/O and Gigabit Ethernet applications
in harsh environments**

FOREWORD

- 1) The International Electrotechnical Commission (IEC) is a worldwide organization for standardization comprising all national electrotechnical committees (IEC National Committees). The object of IEC is to promote international co-operation on all questions concerning standardization in the electrical and electronic fields. To this end and in addition to other activities, IEC publishes International Standards, Technical Specifications, Technical Reports, Publicly Available Specifications (PAS) and Guides (hereafter referred to as “IEC Publication(s)”). Their preparation is entrusted to technical committees; any IEC National Committee interested in the subject dealt with may participate in this preparatory work. International governmental and non-governmental organizations liaising with the IEC also participate in this preparation. IEC collaborates closely with the International Organization for Standardization (ISO) in accordance with conditions determined by agreement between the two organizations.
- 2) The formal decisions or agreements of IEC on technical matters expressed, as nearly as possible, an international consensus of opinion on the relevant subjects since each technical committee has representation from all interested IEC National Committees.
- 3) IEC Publications have the form of recommendations for international use and are accepted by IEC National Committees in that sense. While all reasonable efforts are made to ensure that the technical content of IEC Publications is accurate, IEC cannot be held responsible for the way in which they are used or for any misinterpretation by any end user.
- 4) In order to promote international uniformity, IEC National Committees undertake to apply IEC Publications transparently to the maximum extent possible in their national and regional publications. Any divergence between any IEC Publication and the corresponding national or regional publication shall be clearly indicated in the latter.
- 5) IEC itself does not provide any attestation of conformity. Independent certification bodies provide conformity assessment services and, in some areas, access to IEC marks of conformity. IEC is not responsible for any services carried out by independent certification bodies.
- 6) All users should ensure that they have the latest edition of this publication.
- 7) No liability shall attach to IEC or its directors, employees, servants or agents including individual experts and members of its technical committees and IEC National Committees for any personal injury, property damage or other damage of any nature whatsoever, whether direct or indirect, or for costs (including legal fees) and expenses arising out of the publication, use of, or reliance upon, this IEC Publication or any other IEC Publications.
- 8) Attention is drawn to the Normative references cited in this publication. Use of the referenced publications is indispensable for the correct application of this publication.
- 9) Attention is drawn to the possibility that some of the elements of this IEC Publication may be the subject of patent rights. IEC shall not be held responsible for identifying any or all such patent rights.

International Standard IEC 61076-3-122 has been prepared by subcommittee 48B: Electrical connectors, of IEC technical committee 48: Electrical connectors and mechanical structures for electrical and electronic equipment.

The text of this International Standard is based on the following documents:

| FDIS | Report on voting |
|---------------|------------------|
| 48B/2554/FDIS | 48B/2563/RVD |

Full information on the voting for the approval of this International Standard can be found in the report on voting indicated in the above table.

This document has been drafted in accordance with the ISO/IEC Directives, Part 2.

A list of all parts in the IEC 61076 series, published under the general title *Connectors for electronic equipment – Product requirements*, can be found on the IEC website.

The committee has decided that the contents of this document will remain unchanged until the stability date indicated on the IEC website under "<http://webstore.iec.ch>" in the data related to the specific document. At this date, the document will be

- reconfirmed,
- withdrawn,
- replaced by a revised edition, or
- amended.

IMPORTANT – The 'colour inside' logo on the cover page of this publication indicates that it contains colours which are considered to be useful for the correct understanding of its contents. Users should therefore print this document using a colour printer.

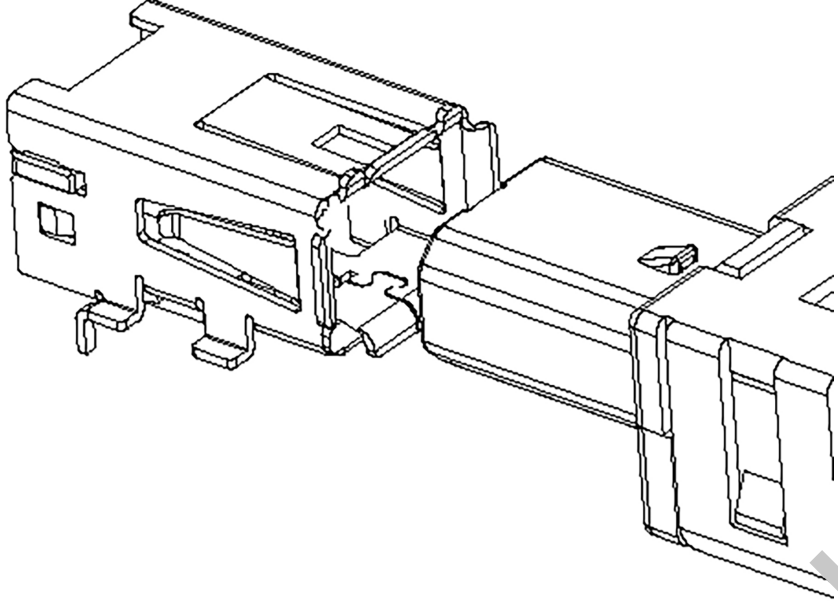
| | |
|--|---|
| | IEC 61076-3-122:2017 |
| Subcommittee 48B: Electrical connectors | |
|  <p style="text-align: right; margin-right: 20px;">IEC</p> | <p>Detail specification for 8-way, shielded, free and fixed connectors for I/O and Gigabit Ethernet applications in harsh environments</p> |
| <p>NOTE The above view shows a Type I connector pair, with coding edges on a short side; for Type II connectors the coding edges are located on a long side.</p> | <p>Fixed connectors are mounted on printed circuit board by means of soldering or press-in, the free connector is attached to wires by means of soldering, crimping, IDC or other termination technology.</p> |

currently in preview, click buy full version

CONNECTORS FOR ELECTRICAL AND ELECTRONIC EQUIPMENT – PRODUCT REQUIREMENTS –

Part 3-122: Detail specification for 8-way, shielded, free and fixed connectors for I/O and Gigabit Ethernet applications in harsh environments

1 Scope

This part of IEC 61076 covers 8-way, shielded, free and fixed rectangular connectors for I/O and Gigabit Ethernet applications, suitable for use in harsh environments, and is intended to specify the common dimensions, mechanical, electrical and environmental characteristics and tests for this family of connectors.

2 Normative references

The following documents are referred to in the text in such a way that some or all of their content constitutes requirements of this document. For dated references, only the edition cited applies. For undated references, the latest edition of the referenced document (including any amendments) applies.

IEC 60050-581, *International Electrotechnical Vocabulary (IEV) – Chapter 581: Electromechanical components for electronic equipment*

IEC 60068-1, *Environmental testing – Part 1: General and guidance*

IEC 60068-2-38, *Environmental testing – Part 2-38: Tests – Test Z/AD: Composite temperature/humidity cyclic test*

IEC 60512-1, *Connectors for electronic equipment – Tests and measurements – Part 1: General*

IEC 60512-1-1, *Connectors for electronic equipment – Tests and measurements – Part 1-1: General examination – Test 1a: Visual examination*

IEC 60512-1-2, *Connectors for electronic equipment – Tests and measurements – Part 1-2: General examination – Test 1b: Examination of dimension and mass*

IEC 60512-2-1, *Connectors for electronic equipment – Tests and measurements – Part 2-1: Electrical continuity and contact resistance tests – Test 2a: Contact resistance – Millivolt level method*

IEC 60512-3-1, *Connectors for electronic equipment – Tests and measurements – Part 3-1: Insulation tests – Test 3a: Insulation resistance*

IEC 60512-4-1, *Connectors for electronic equipment – Tests and measurements – Part 4-1: Voltage stress tests – Test 4a: Voltage proof*

IEC 60512-5-2, *Connectors for electronic equipment – Tests and measurements – Part 5-2: Current-carrying capacity tests – Test 5b: Current-temperature derating*