

INTERNATIONAL STANDARD

**Electrical installations in ships –
Part 302-2: Low voltage switchgear and controlgear assemblies – Marine power**





THIS PUBLICATION IS COPYRIGHT PROTECTED

Copyright © 2019 IEC, Geneva, Switzerland

All rights reserved. Unless otherwise specified, no part of this publication may be reproduced or utilized in any form or by any means, electronic or mechanical, including photocopying and microfilm, without permission in writing from either IEC or IEC's member National Committee in the country of the requester. If you have any questions about IEC copyright or have an enquiry about obtaining additional rights to this publication, please contact the address below or your local IEC member National Committee for further information.

IEC Central Office
3, rue de Varembe
CH-1211 Geneva 20
Switzerland

Tel.: +41 22 919 02 11
info@iec.ch
www.iec.ch

About the IEC

The International Electrotechnical Commission (IEC) is the leading global organization that prepares and publishes International Standards for all electrical, electronic and related technologies.

About IEC publications

The technical content of IEC publications is kept under constant review by the IEC. Please make sure that you have the latest edition, a corrigendum or an amendment might have been published.

IEC publications search - webstore.iec.ch/advsearchform

The advanced search enables to find IEC publications by a variety of criteria (reference number, text, technical committee,...). It also gives information on projects, replaced and withdrawn publications.

IEC Just Published - webstore.iec.ch/justpublished

Stay up to date on all new IEC publications. Just Published details all new publications released. Available online and once a month by email.

IEC Customer Service Centre - webstore.iec.ch/csc

If you wish to give us your feedback on this publication or need further assistance, please contact the Customer Service Centre: sales@iec.ch.

Electropedia - www.electropedia.org

The world's leading online dictionary on electrotechnology, containing more than 22 000 terminological entries in English and French, with equivalent terms in 16 additional languages. Also known as the International Electrotechnical Vocabulary (IEV) online.

IEC Glossary - webstore.iec.ch/glossary

67 000 electrotechnical terminology entries in English and French extracted from the Terms and Definitions clause of IEC publications issued since 2002. Some entries have been collected from earlier publications of IEC TC 37, 77, 86 and CISPR.

INTERNATIONAL STANDARD

**Electrical installations in ships –
Part 302-2: Low voltage switchgear and controlgear assemblies – Marine power**

INTERNATIONAL
ELECTROTECHNICAL
COMMISSION

ICS 47.020.60

ISBN 978-2-8322-6662-5

Warning! Make sure that you obtained this publication from an authorized distributor.

CONTENTS

FOREWORD.....	3
INTRODUCTION.....	5
1 Scope.....	6
2 Normative references	6
3 Terms and definitions	6
4 Symbols and abbreviations.....	7
5 Interface characteristics.....	7
6 Information	8
7 Service conditions	9
8 Constructional requirements.....	9
9 Performance requirements.....	12
10 Design verification	13
11 Routine verification.....	15
Annex AAA (informative) Items subject to agreement between the assembly manufacturer and the user.....	19
Bibliography.....	24
Figure 201 – Relationship of standards	5
Table 1 – Minimum clearances in air (8.3.2).....	15
Table 2 – Minimum creepage distances (8.3.3).....	16
Table 6 – Temperature rise limits (9.2).....	17
Table AAA.1 – Items subject to agreement between the assembly manufacturer and the user	19

INTERNATIONAL ELECTROTECHNICAL COMMISSION

ELECTRICAL INSTALLATIONS IN SHIPS –**Part 302-2: Low voltage switchgear and
controlgear assemblies – Marine power**

FOREWORD

- 1) The International Electrotechnical Commission (IEC) is a worldwide organization for standardization comprising all national electrotechnical committees (IEC National Committees). The object of IEC is to promote international co-operation on all questions concerning standardization in the electrical and electronic fields. To this end and in addition to other activities, IEC publishes International Standards, Technical Specifications, Technical Reports, Publicly Available Specifications (PAS) and Guides (hereafter referred to as “IEC Publication(s)”). Their preparation is entrusted to technical committees; any IEC National Committee interested in the subject dealt with may participate in this preparatory work. International, governmental and non-governmental organizations liaising with the IEC also participate in this preparation. IEC collaborates closely with the International Organization for Standardization (ISO) in accordance with conditions determined by agreement between the two organizations.
- 2) The formal decisions or agreements of IEC on technical matters express, as nearly as possible, an international consensus of opinion on the relevant subjects since each technical committee has representation from all interested IEC National Committees.
- 3) IEC Publications have the form of recommendations for international use and are accepted by IEC National Committees in that sense. While all reasonable efforts are made to ensure that the technical content of IEC Publications is accurate, IEC cannot be held responsible for the way in which they are used or for any misinterpretation by any end user.
- 4) In order to promote international uniformity, IEC National Committees undertake to apply IEC Publications transparently to the maximum extent possible in their national and regional publications. Any divergence between any IEC Publication and the corresponding national or regional publication shall be clearly indicated in the latter.
- 5) IEC itself does not provide any attestation of conformity. Independent certification bodies provide conformity assessment services and, in some areas, accept IEC marks of conformity. IEC is not responsible for any services carried out by independent certification bodies.
- 6) All users should ensure that they have the latest edition of this publication.
- 7) No liability shall attach to IEC or its directors, employees, servants or agents including individual experts and members of its technical committees and IEC National Committees for any personal injury, property damage or other damage of any nature whatsoever, whether direct or indirect, or for costs (including legal fees) and expenses arising out of the publication, use of, or reliance upon, this IEC Publication or any other IEC Publications.
- 8) Attention is drawn to the normative references cited in this publication. Use of the referenced publications is indispensable for the correct application of this publication.
- 9) Attention is drawn to the possibility that some of the elements of this IEC Publication may be the subject of patent rights. IEC shall not be held responsible for identifying any or all such patent rights.

International Standard IEC 60092-302-2 has been prepared by IEC technical committee 18: Electrical installations of ships and of mobile and fixed offshore units.

This first edition cancels and replaces the fourth edition of IEC 60092-302 published in 1997. This edition constitutes a technical revision.

This edition includes the following significant technical changes with respect to the previous edition:

- a) this document has been renumbered to fall in line with IEC 61439 (all parts);
- b) this document has been restructured to fall in line with IEC 61439 (all parts);
- c) the creepage distances have been modified;
- d) the references to non type tested assemblies (NTTA) have been removed;
- e) non-applicable tables have been removed;

- f) the applicability of IEC 61439 (all parts) annexes have been identified.
- g) specific requirements that were detailed in IEC 60092-302:1997, covered under 7.6.101 have partly been moved to 60092-201.

The text of this document is based on the following documents:

FDIS	Report on voting
18/1656/FDIS	18/1668/RVD

Full information on the voting for the approval of this International Standard can be found in the report on voting indicated in the above table.

This document has been drafted in accordance with the ISO/IEC Directives, Part 2.

This International Standard is to be used in conjunction with IEC 61439-1:2011 and IEC 61439-2:2011.

This document supplements or modifies the corresponding clauses in IEC 61439-1:2011 and IEC 61439-2:2011. Where this document states "addition", "deletion" or "replacement", the relevant text of IEC 61439-1:2011 and IEC 61439-2:2011 is adapted accordingly.

Clauses and subclauses which are additional to those of IEC 61439-1:2011 and IEC 61439-2:2011 are numbered starting from 201. Additional annexes are numbered starting from AAA.

In this document, terms written in small capitals are defined in Clause 3.

Where the abbreviated term PSC-assembly is used in applicable clauses of IEC 61439-2:2011, this refer to MPSC-assembly.

A list of all parts in the IEC 60092 series, published under the general title *Electrical installations in ships*, can be found on the IEC website.

The committee has decided that the contents of this document will remain unchanged until the stability date indicated on the IEC website under "<http://webstore.iec.ch>" in the data related to the specific document. At this date, the document will be

- reconfirmed,
- withdrawn,
- replaced by a revised edition, or
- amended.

A bilingual version of this publication may be issued at a later date.

INTRODUCTION

This part of IEC 60092 forms a series of International Standards for electrical installations in sea-going ships, incorporating good practice and coordinating, as far as possible, existing rules.

These standards form a code of practical interpretation and amplification of the requirements of the International Convention for the Safety of Life at Sea, a guide for future regulations which may be prepared and a statement of practice for use by ship owners, shipbuilders and appropriate organizations.

IEC 61439 (all parts) identifies the requirements for land based low voltage switchgear and controlgear assemblies. IEC 60092-302 (all parts) has been developed in-line with Figure 201 which shows the future intention to develop appropriate marine standards for final distribution boards to be operated by ordinary persons; and busbar trunking systems.

IEC 60092 (all parts) remains the lead standard series for electrical installations in ships, and the applicable standards are applied accordingly. Wherever there are differences between IEC 61439 (all parts) and IEC 60092 (all parts), IEC 60092 (all parts) takes precedence.

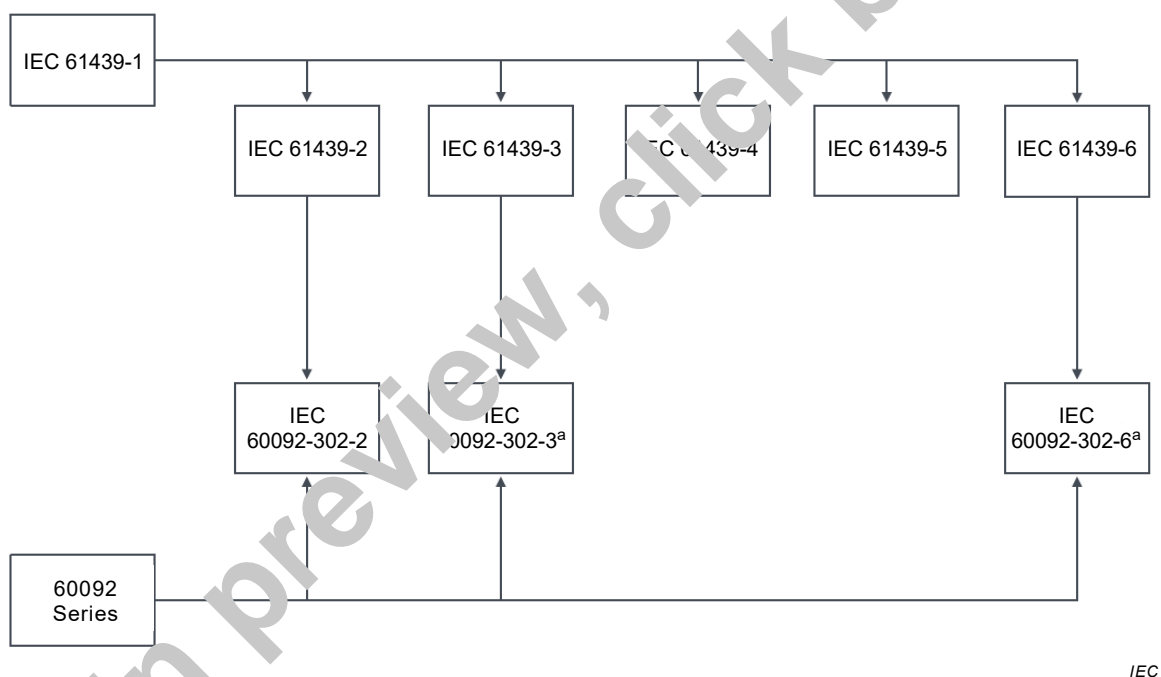

Key

^a Under consideration.

NOTE – At the time of publication, IEC 60092-302-3 and IEC 60092-302-6 are not developed. The figure shows that these standards are potential future projects to align with the IEC 61439 series.

Figure 201 – Relationship of standards

ELECTRICAL INSTALLATIONS IN SHIPS –

Part 302-2: Low voltage switchgear and controlgear assemblies – Marine power

1 Scope

This part of IEC 60092 defines the specific requirements of low voltage marine power switchgear and controlgear assemblies (MPSC-assemblies) as follows:

- stationary assemblies with enclosure for which the rated voltage does not exceed 1 000 V AC or 1500 V DC;
- assemblies intended for use in conjunction with the power generation, distribution and conversion of electric energy, and for the control of electric energy consuming equipment.

This document applies to all assemblies whether they are designed, manufactured and verified on a one-off basis or fully standardised and manufactured in quantity.

The manufacture and/or assembly can be carried out other than by the original manufacturer.

This document does not apply to individual devices and self-contained components, such as motor starters, fuse switches, electronic equipment, which comply with the relevant product standards.

NOTE Individual devices and components include those that are covered by the IEC 60947 series.

2 Normative references

The following documents are referred to in the text in such a way that some or all of their content constitutes requirements of this document. For dated references, only the edition cited applies. For undated references, the latest edition of the referenced document (including any amendments) applies.

IEC 60092-101:2018, *Electrical installations in ships – Part 101: Definitions and general requirements*

IEC 60092-201:2019, *Electrical installations in ships – Part 201: System design – General*

IEC 60533, *Electrical and electronic installations in ships – Electromagnetic compatibility (EMC) – Ships with a metallic hull*

IEC 61439-1:2011, *Low-voltage switchgear and controlgear assemblies – Part 1: General rules*

IEC 61439-2:2011, *Low-voltage switchgear and controlgear assemblies – Part 2: Power switchgear and controlgear assemblies*

3 Terms and definitions

For the purposes of this document, the following terms and definitions apply.