

**CSA B45.5-11/  
IAPMO Z124-2011**

## Plastic plumbing fixtures



# Legal Notice for Harmonized Standard Jointly Developed by CSA and IAPMO

## Intellectual property rights and ownership

As between Canadian Standards Association ("CSA") and International Association of Plumbing and Mechanical Officials ("IAPMO") (collectively "CSA and IAPMO") and the users of this document (whether it be in printed or electronic form), CSA and IAPMO are the joint owners of all works contained herein that are protected by copyright, all trade-marks (except as otherwise noted to the contrary), and all inventions and trade secrets that may be contained in this document, whether or not such inventions and trade secrets are protected by patents and applications for patents. The unauthorized use, modification, copying, or disclosure of this document may violate laws that protect the intellectual property of CSA and IAPMO and may give rise to a right in CSA and IAPMO to seek legal redress for such use, modification, copying, or disclosure. CSA and IAPMO reserve all intellectual property rights in this document.

## Disclaimer and exclusion of liability

This document is provided without any representations, warranties, or conditions of any kind, express or implied, including, without limitation, implied warranties or conditions concerning this document's fitness for a particular purpose or use, its merchantability, or its non-infringement of any third party's intellectual property rights. CSA and IAPMO do not warrant the accuracy, completeness, or currency of any of the information published in this document. CSA and IAPMO make no representations or warranties regarding this document's compliance with any applicable statute, rule, or regulation.

IN NO EVENT SHALL CSA AND IAPMO, THEIR RESPECTIVE VOLUNTEERS, MEMBERS, SUBSIDIARIES, OR AFFILIATED COMPANIES, OR THEIR EMPLOYEES, DIRECTORS, OR OFFICERS, BE LIABLE FOR ANY DIRECT, INDIRECT, OR INCIDENTAL DAMAGES, INJURY, LOSS, COSTS, OR EXPENSES, HOWSOEVER CAUSED, INCLUDING BUT NOT LIMITED TO SPECIAL OR CONSEQUENTIAL DAMAGES, LOST REVENUE, BUSINESS INTERRUPTION, LOST OR DAMAGED DATA, OR ANY OTHER COMMERCIAL OR ECONOMIC LOSS, WHETHER BASED IN CONTRACT, TORT (INCLUDING NEGLIGENCE), OR ANY OTHER THEORY OF LIABILITY, ARISING OUT OF OR RESULTING FROM ACCESS TO OR POSSESSION OR USE OF THIS DOCUMENT, EVEN IF CSA OR IAPMO HAVE BEEN ADVISED OF THE POSSIBILITY OF SUCH DAMAGES, INJURY, LOSS, COSTS, OR EXPENSES.

In publishing and making this document available, CSA and IAPMO are not undertaking to render professional or other services for or on behalf of any person or entity or to perform any duty owed by any person or entity to another person or entity. The information in this document is directed to those who have the appropriate degree of competence to use and apply its contents, and CSA and IAPMO accept no responsibility whatsoever arising in any way from any and all use of or reliance on the information contained in this document.

CSA and IAPMO have no power, nor do they undertake, to enforce compliance with the contents of the standards or other documents they jointly publish.

## Authorized use of this document

This document is being provided by CSA and IAPMO for informational and non-commercial use only. The user of this document is authorized to do only the following:

If this document is in electronic form:

- load this document onto a computer for the sole purpose of reviewing it;
- search and browse this document; and
- print this document if it is in PDF format.

Limited copies of this document in print or paper form may be distributed only to persons who are authorized by CSA and IAPMO to have such copies, and only if this Legal Notice appears on each such copy.

In addition, users may not and may not permit others to

- alter this document in any way or remove this Legal Notice from the attached standard;
- sell this document without authorization from CSA and IAPMO; or
- make an electronic copy of this document.

If you do not agree with any of the terms and conditions contained in this Legal Notice, you may not load or use this document or make any copies of the contents hereof, and if you do make such copies, you are required to destroy them immediately. Use of this document constitutes your acceptance of the terms and conditions of this Legal Notice.

# **Update No. 1**

## **CSA B45.5-11/IAPMO Z124-2011**

### **May 2012**

**Note:** General Instructions for CSA Standards are now called Updates. Please contact CSA Information Products Sales or visit [shop.csa.ca](http://shop.csa.ca) for information about the **CSA Standards Update Service**.

**Title:** *Plastic plumbing fixtures* — originally published October 2011

The following revisions have been formally approved and are marked by the symbol delta ( $\Delta$ ) in the margin on the attached replacement pages:

<b>Revised</b>	Clauses 2, 4.2.2, 5.6.1(c), 5.22, and Figure 7
<b>New</b>	None
<b>Deleted</b>	None

- Update your copy by inserting these revised pages.
- Keep the pages you remove for reference.

Currently in preview, click buy full version

# CSA B45.5-11/IAPMO Z124-2011

## *Plastic plumbing fixtures*

### **0 Introduction**

#### **0.1**

This harmonized Standard was developed in response to an industry request for a Standard for evaluation of plastic plumbing fixtures that would be acceptable for use in both Canada and the United States. Standards for plumbing fixtures made of other materials are also available or under development.

#### **0.2**

Harmonization activities for plastic plumbing fixtures Standards were undertaken in 2005 by Joint Harmonization Task Group (JHTG) on Plumbing Fixtures, in which the CSA and IAPMO plumbing fixtures committees were equally represented. The responsibility for procedural matters and final approval of technical content was assumed by technical committees at higher levels within each SDC.

### **1 Scope**

#### **1.1**

This Standard covers plastic plumbing fixtures and specifies requirements for materials, construction, performance, testing, and markings.

#### **1.2**

This Standard covers the following plumbing fixtures:

- (a) bathtubs and combination tub/showers;
- (b) lavatories;
- (c) shower bases and shower stalls;
- (d) sinks:
  - (i) bar sinks;
  - (ii) kitchen sinks;
  - (iii) laundry sinks; and
  - (iv) service sinks;
- (e) urinals; and
- (f) water closets.

#### **1.3**

In this Standard, “shall” is used to express a requirement, i.e., a provision that the user is obliged to satisfy in order to comply with the standard; “should” is used to express a recommendation or that which is advised but not required; and “may” is used to express an option or that which is permissible within the limits of the standard.

Notes accompanying clauses do not include requirements or alternative requirements; the purpose of a note accompanying a clause is to separate from the text explanatory or informative material.

References to tables and figures are considered part of the table or figure and may be written as requirements.

Annexes are designated normative (mandatory) or informative (nonmandatory) to define their application.

## 1.4

SI units are the units of record in Canada. In this Standard, the inch/pound units are shown in parentheses. The values stated in each measurement system are equivalent in application; however, each system is to be used independently. Combining values from the two measurement systems can result in non-conformance with this Standard.

All references to gallons are to U.S. gallons.

For information on the conversion criteria used in this Standard, see Annex A.

## 2 Reference publications

This Standard refers to the following publications, and where such reference is made, it shall be to the edition listed below, including all amendments published thereto.

### **CSA (Canadian Standards Association)**

CAN/CSA-B651-04 (R2010)

*Accessible design for the built environment*

C22.2 No. 0.15-01 (R2006)

*Adhesive labels*

### **ASME/CSA (The American Society of Mechanical Engineers/Canadian Standards Association)**

ASME A112.18.1-2011/CSA B125.1-11

*Plumbing supply fittings*

ASME A112.18.2-2011/CSA B125.2-11

*Plumbing waste fittings*

ASME A112.19.1-2008/CSA B45.2-08

*Enamelled cast iron and enamelled steel plumbing fixtures*

ASME A112.19.2-2008/CSA B45.1-08

*Ceramic plumbing fixtures*

ASME A112.19.3-2008/CSA B45.4-08

*Stainless steel plumbing fixtures*

Δ ASME A112.19.15-2012

*Bathtubs/whirlpool bathtubs with pressure sealed doors*

### **ASTM International (American Society for Testing and Materials)**

C297/C297M-04

*Standard Test Method for Pointwise Tensile Strength of Sandwich Constructions*

D883-08

*Standard Terminology Relating to Plastics*

D2214-08

*Standard Practice for Calculation of Color Tolerances and Color Differences from Instrumentally Measured Color Coordinates*

D2565-99 (2008)

*Standard Practice for Xenon-Arc Exposure of Plastics Intended for Outdoor Applications*

G21-09

*Standard Practice for Determining Resistance of Synthetic Polymeric Materials to Fungi*

## 4.2 Waste fitting openings, drainage, and overflows

### 4.2.1 Openings and drainage

#### 4.2.1.1

Fixtures shall

- (a) have a waste fitting opening (outlet), the centre of which shall be located at the lowest point of the fixture; and
- (b) drain to the waste outlet.

#### 4.2.1.2

Except when proprietary (i.e., non-standard) waste fittings are provided by the manufacturer, the dimensions of waste outlets shall be as shown in Figure 1.

#### 4.2.1.3

Factory-supplied waste fittings shall comply with ASME A112.18.2/CSA B125.2.

### Δ 4.2.2 Overflows (for lavatories and sinks only)

#### 4.2.2.1 Provision and positioning

Overflows in lavatories and sinks may be provided at the option of the manufacturer. When overflows are provided, their position in the fixture shall be at the option of the manufacturer.

#### 4.2.2.2 Overflows in sinks intended for food preparation

When provided, overflows in sinks intended for food preparation (e.g., kitchen and bar sinks) shall not be concealed and shall be accessible for disassembly and cleaning after installation.

#### 4.2.2.3 Performance

When provided, overflows shall comply with Clause 5.19.

## 4.3 Lavatories and sinks

### 4.3.1 Openings and mounting surfaces for supply fittings

#### 4.3.1.1

When provided, openings and mounting surfaces for lavatory and sink supply fittings shall be as shown in Figure 2, 3, 4, 5, or 6, as applicable, except when proprietary (i.e., non-standard) supply fittings are provided by the manufacturer.

#### 4.3.1.2

Factory-supplied supply fittings shall comply with ASME A112.18.1/CSA B125.1.

#### 4.3.1.3

Mounting surfaces for supply fittings that rely on an air gap for backflow protection shall be not more than 13 mm (0.5 in) below the flood level rim.

*Note.* Care should be taken to ensure that the minimum air gap specified in ASME A112.18.1/CSA B125.1 or in the applicable plumbing code is not compromised when supply fittings are installed on fixtures with mounting surfaces below the flood level rim.

## 4.4 Bathtubs and shower bases

### 4.4.1 Flanges

Bathtubs intended for installation against a wall shall incorporate a flange raised at least 8 mm (0.3 in) above the rim, as shown in Figure 7. Shower bases intended for installation against a wall shall incorporate a continuously raised flange at least 25 mm (1.0 in) above the threshold, as shown in Figure 8. The flange shall be

- (a) integral with the bathtub or shower base;
- (b) added to an island tub or shower base in the factory; or
- (c) field-installed using a flange kit that complies with Clause 5.18 and includes all necessary parts and fasteners.

Bathtubs and shower bases using field-installed flanges shall be marked in accordance with Clause 6.3.

In addition, the bottom of any hole in the flange or corner treatment shall be not less than 8 mm (0.3 in) above the rim.

### 4.4.2 Slope to the waste outlet

Bathtubs and shower bases shall have a maximum slope of 4% to the waste outlet.

**Note:** *There should be a minimum slope of 1% to the waste outlet.*

### 4.4.3 Minimum dimensions for bathtubs

The minimum dimensions for bathtubs shall be as shown in Figure 7.

Variations in location, geometry, diameter, and angle of orientation of the overflow opening shall be acceptable when factory-provided waste and overflow fittings are used.

### 4.4.4 Shower base thresholds

Except for accessible designs, when provided, shower base thresholds shall be at least 50 mm (2 in) above the top of the waste outlet, as shown in Figure 8.

### 4.4.5 Diameter, spacing, and grippable length of grab bars

Grab bars intended for residential and commercial installations shall have a

- (a) diameter of between 22 and 40 mm (0.86 in and 1.575 in) or an equivalent cross-sectional area;
- (b) spacing of at least 25 mm (1 in) between the finished wall and the inside grippable surface of the grab bar; and
- (c) minimum grippable length of 228 mm (9.0 in), centred over the span of the bar.

### 4.4.6 Bathtubs with pressure sealed doors

Bathtubs with pressure sealed doors shall comply with ASME A112.19.15.

## 4.5 Water closets

Water closets and their flushing devices shall comply with the applicable requirements of ASME A112.19.2/CSA B45.1, except that the structural integrity tests for floor-mounted water closets shall be conducted in accordance with Clause 5.8.8.

## 4.6 Urinals

### 4.6.1

Urinals and their flushing devices shall comply with the applicable requirements of ASME A112.19.2/CSA B45.1.

### 4.6.2

In addition to complying with the applicable requirements of this Standard, non-water-consuming urinals shall comply with ASME A112.19.19.

### 5.5.2 Performance

There shall be no visible voids larger than 1.6 mm (0.063 in) in diameter below the original finish surface, and the maximum allowable number of voids smaller than 1.6 mm (0.063 in) for the two test areas shall be eight.

## 5.6 Waste fitting connection test

### 5.6.1 Procedure for bathtubs and shower bases

The waste fitting connection test for bathtubs and shower bases shall be conducted as follows:

- (a) Wash the specimen with a solution of standard liquid detergent and water, rinse with water, and dry.
- (b) Apply a  $220 \pm 4$  N ( $50 \pm 1$  lbf) load using a  $610 \pm 6$  mm ( $24 \pm 0.25$  in) lever arm connected to the waste fitting and extending horizontally as shown in Figure 9.
- Δ (c) Ensure that the load application does not exceed the test parameter by gradually applying the load over 5 to 10 s. Any combination of weight and lever arm may be used in lieu of the weight and lever arm specified in Item (b) as long as the bending moment is 136 N-m (100 ft-lb).
- (d) Apply the load for 1 min in two additional radial locations. Two of the three locations shall be approximately  $180^\circ$  apart.
- (e) Examine the specimen in accordance with Items (b) to (d) of Clause 5.4.1.

### 5.6.2 Procedure for other fixtures

Fixtures other than bathtubs and shower bases shall be tested in accordance with Clause 5.6.1 except that a load of  $110 \pm 4$  N ( $25 \pm 1$  lbf) shall be used.

### 5.6.3 Performance

There shall be no visible cracks in the bottom surface of the specimen.

## 5.7 Point impact load test

### 5.7.1 Procedures

#### 5.7.1.1 General

The point impact load test shall be conducted using a steel ball with a diameter of 38 mm (1.5 in) and a weight of  $2.20 \pm 0.05$  N ( $0.50 \pm 0.01$  lb). The ball shall be free of gouges, deformations, and other surface defects.

#### 5.7.1.2 Bathtubs and shower bases

The point impact load test for bathtubs and shower bases shall be conducted as follows:

- (a) Wash the specimen with a solution of standard liquid detergent and water, rinse with water, and dry.
- (b) Drop the steel ball specified in Clause 5.7.1.1 from a height of 900 mm (36 in) to strike six different locations, as follows:
  - (i) three different locations on flat areas in the bottom of the specimen; and
  - (ii) three different locations on the rim or threshold.
- (c) Drop the steel ball from a height of 600 mm (24 in) to strike three different locations on radii in the bottom of the specimen. At least one strike shall be in a corner.

#### 5.7.1.3 Sinks

The point impact load test for sinks shall be conducted as follows:

- (a) Wash the specimen with a solution of standard liquid detergent and water, rinse with water, and dry.
- (b) Drop the steel ball specified in Clause 5.7.1.1 from a height of 600 mm (24 in) to strike four different locations in each sink compartment, as follows:
  - (i) two different locations on the flat area of the sink bottom; and
  - (ii) two different locations on the convex rim radius.

Utility sinks without rolled rims shall be impacted only on the compartment bottom.

Additionally, sinks with tops or integral tops and drain boards shall be impacted on three different points on flat areas.

#### 5.7.1.4 Lavatories

The point impact load test for lavatories shall be conducted as follows:

- (a) Wash the specimen with a solution of standard liquid detergent and water, rinse with water, and dry.
- (b) Drop the steel ball specified in Clause 5.7.1.1 three times from a height of 500 mm (20 in) to strike three different locations on flat areas on the top of the specimen.
- (c) Drop the steel ball from a height of 500 mm (20 in) to strike three different locations inside the specimen bowl, as follows:
  - (i) adjacent to the waste opening;
  - (ii) 100 mm (4 in) from the drain; and
  - (iii) on a sloping area of the specimen.

#### 5.7.2 Performance

There shall be no cracks or chips in the surface of the specimen when examined in accordance with Items (b) to (d) of Clause 5.4.1.

### 5.8 Structural integrity tests

#### 5.8.1 Load test for bathtub and shower seats

**Note:** The seat can be an integrally moulded part of the bathtub or shower base, or mechanically attached to the fixture.

##### 5.8.1.1 Procedure

The load test for bathtub and shower seats shall be conducted as follows:

- (a) Load the specimen with a  $1335 \pm 22$  N ( $300 \pm 5$  lbf) test load applied to the centre of the seat using a 150 mm (6 in) diameter load-distribution disk resting on a 13 mm (0.5 in) thick sponge rubber or equivalent pad.
- (b) Leave the load in place for at least 2 min.

##### 5.8.1.2 Performance

There shall be no cracks or other signs of failure in the surface of the seat or in the area around the seat when examined in accordance with Items (b) to (d) of Clause 5.4.1.

#### 5.8.2 Load test for bathtub rims and bottoms and shower thresholds and bottoms

##### 5.8.2.1 General

Bathtub rims and bottoms shall be tested in accordance with either Clause 5.8.2.2.1 or 5.8.2.2.2 and Clause 5.8.2.2.3. Shower thresholds and bottoms shall be tested in accordance with Clauses 5.8.2.2.1 and 5.8.2.2.3.

##### 5.8.2.2 Procedures

##### 5.8.2.2.1 Procedure for bathtub rims and bottoms and shower thresholds and bottoms

**Note:** See Clause 5.8.2.2.3 for secondary load testing.

The load test for bathtub rims and bottoms and shower thresholds and bottoms shall be conducted as follows:

- (a) Preload the specimen with a  $1335 \pm 22$  N ( $300 \pm 5$  lbf) test load applied to the centre of the bottom of the specimen using a 76 mm (3 in) diameter load-distribution disk resting on a 13 mm (0.5 in) thick sponge rubber or equivalent pad.

Discolouration that can be removed by abrading the surface to a maximum depth of 0.125 mm (0.005 in) and repolishing in accordance with the manufacturer's care and maintenance instructions shall be acceptable.

## 5.18 Field-installed tiling-flange seal test

### 5.18.1 Procedure

The tiling-flange seal test shall be conducted as follows:

- (a) Set up and load the specimen in accordance with Clause 5.8.1.1.
- (b) Maintain the load for the full duration of the test.
- (c) Apply a continuous water spray to the flange seal at the joint with the fixture as follows:
  - (i) using a 30° full jet spray nozzle;
  - (ii) for 30 min;
  - (iii) from a distance of 1.2 m (4 ft) from the face of the spray nozzle;
  - (iv) at an angle of 45°;
  - (v) at a flow rate of 11.4 L/min (3.0 gpm); and
  - (vi) at a temperature of  $40 \pm 5$  °C ( $104 \pm 9$  °F).
- (d) Inspect the specimen for water transmission through the joint to the back of the flange.

**Note:** Full Jet®, narrow angle 30° series, part No. 1/2 GG 3030, manufactured by Spraying Systems Co., North Avenue at Schmale Road, P.O. Box 7900, Wheaton, IL, 60189, has been used for this test.

### 5.18.2 Performance

There shall be no water leakage through the flange and fixture joint.

## 5.19 Overflow test

### 5.19.1 Procedure

The overflow test shall be conducted as follows:

- (a) Install the specimen using a waste fitting that complies with ASME A112.18.2/CSA B125.2.
- (b) Supply water to the specimen at a rate of 5.7 L/min (1.5 gpm). If the specimen is a laundry or utility sink, the rate of water supply to the major compartment shall be at least 15 L/min (4 gpm) and to the minor compartment (if any) at least 9 L/min (2.4 gpm).
- (c) Block the waste outlet.
- (d) Measure the elapsed time from the onset of water flowing into the overflow opening until the water begins to flow over the flood level of the specimen.

### 5.19.2 Performance

The specimen shall drain at least 5 min from the onset of water flowing into the overflow opening, without overflowing its flood level rim.

## 5.20 Knife drop test (for kitchen and bar sinks only)

### 5.20.1 Procedure

A steel knife shall be dropped, tip down, from a height of 600 mm (24 in) to strike two different points of the bottom of each compartment.

The knife shall

- (a) have a mass of 28 g (1 oz);
- (b) be  $1.27 \pm 0.13$  mm ( $0.050 \pm 0.005$  in) thick;
- (c) have a rounded tip with a  $6.4 \pm 0.4$  mm ( $0.25 \pm 0.016$  in) radius; and
- (d) have its edge ground to  $0.635 \pm 0.051$  mm ( $0.025 \pm 0.002$  in).

### 5.20.2 Performance

Examine the specimen for cracking and fractures in accordance with Clause 5.4.1(d). The specimen shall not show any cracks or fractures.

Any damage shall not extend through the surface finish. If the damage can be restored to approximate the original finish by using abrasives and polishing compounds, it shall not be deemed a failure.

## 5.21 Skillet drop test (for kitchen sinks only)

### 5.21.1 Procedure

A 270 mm (10.5 in) diameter cast iron skillet weighing  $20 \pm 0.4$  N ( $4.5 \pm 0.1$  lbf) shall be held with the handle up and dropped on two points between the drain and side wall from a height of 300 mm (12 in) in each compartment, approximately 90° apart.

### 5.21.2 Performance

The specimen shall be examined for cracking and fractures in accordance with Items (b) to (d) of Clause 5.4.1 and shall not show any cracks or fractures.

## Δ 5.22 Vibration test (for kitchen sinks only)

### 5.22.1 General

The vibration test shall be conducted only on kitchen sink compartments with a 90 mm (3.5 in) diameter or larger waste outlet.

### 5.22.2 Procedure

The vibration test shall be conducted as follows:

- (a) Add a 15 g (0.53 oz) mass to one of the blades or the disk of a food waste grinder to create an imbalance.
- (b) Locate the mass at a distance of  $57 \pm 3$  mm ( $2.25 \pm 0.13$  in) so that the plane of rotation of the mass is  $156 \pm 6$  mm ( $6.13 \pm 0.25$  in) below the underside of the outer rim and the centre of gravity is  $210 \pm 6$  mm ( $8.25 \pm 0.25$  in) below the underside of the outer rim of a 114 mm (4.5 in) diameter mounting flange.
- (c) Ensure that the overall weight of the grinder is  $84 \pm 2$  N ( $19 \pm 0.5$  lbf).
- (d) Assemble the grinder and attach it to the sink in such a way that the electrical and waste connections do not restrict the motion of the grinder.
- (e) Operate the grinder at  $1725 \pm 3$  rpm.
- (f) Flow cold water through the grinder at a rate of at least 3.8 L/min (1 gpm).
- (g) Turn the grinder on for 30 s and off for 1 min to complete one cycle.
- (h) Subject the specimen to 1000 cycles.

**Note:** An In-Sinkerator Model No. Badger 5XP or equivalent is acceptable.

### 5.22.3 Performance

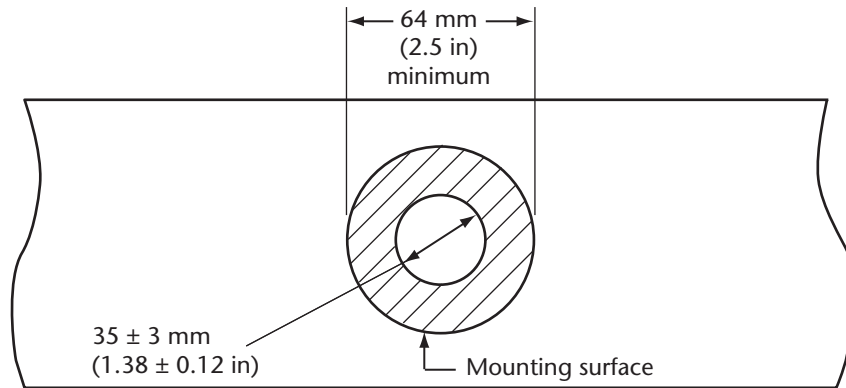
The specimen shall be examined for cracking and fractures in accordance with Items (b) to (d) of Clause 5.4.1 and shall not show any cracks or fractures.

## 5.23 Heated pan test (for kitchen sinks only)

### 5.23.1 Procedure

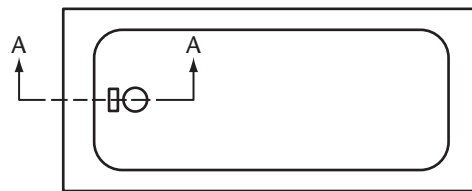
The heated pan test shall be conducted only on kitchen sinks, as follows:

- (a) Mark a test area of  $254 \pm 25$  mm ( $10 \pm 1$  in) in diameter on the bottom of each compartment of the specimen.
- (b) Locate the test area to provide maximum contact with a flat surface.

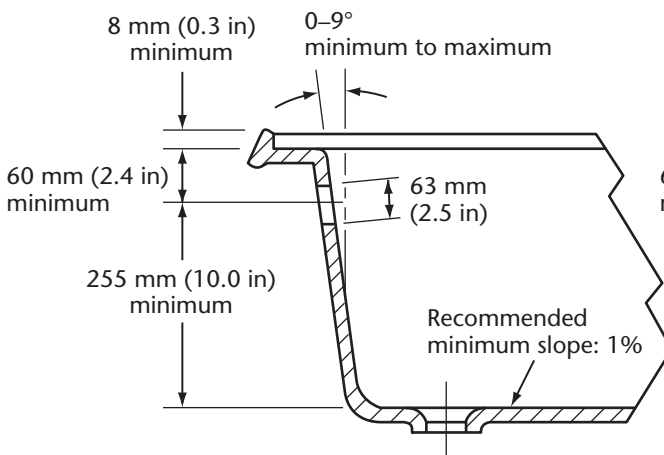


**Figure 6**  
**Opening and mounting surface dimensions**  
**for single-mount supply fittings**

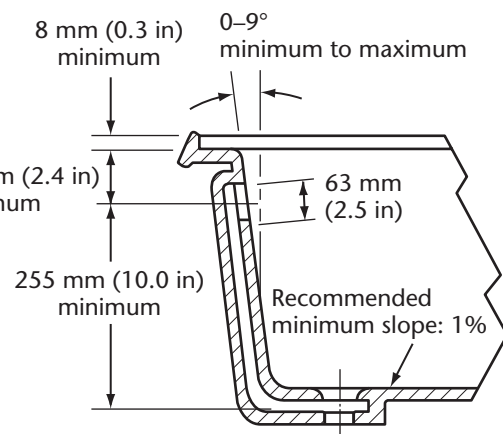
(See Clause 4.3.1.1.)



**(a) Top view**



**(b) Side view section A-A**



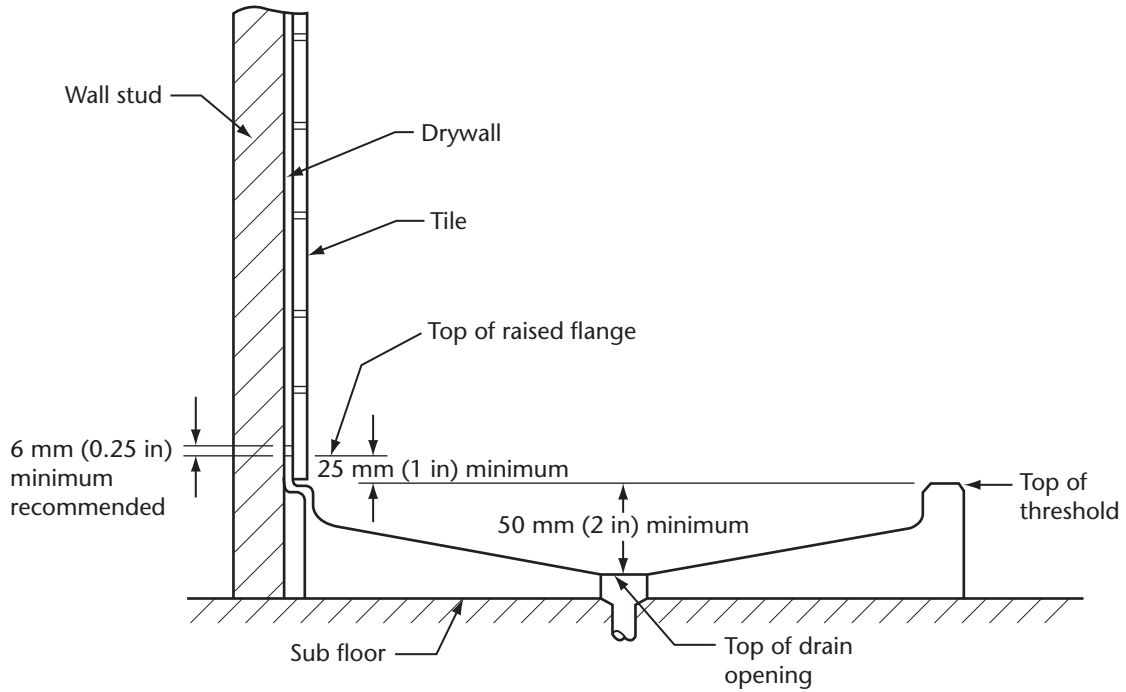
**(c) Side view section A-A for tub with integral overflow**

**Note:** These diagrams are not intended to restrict design.

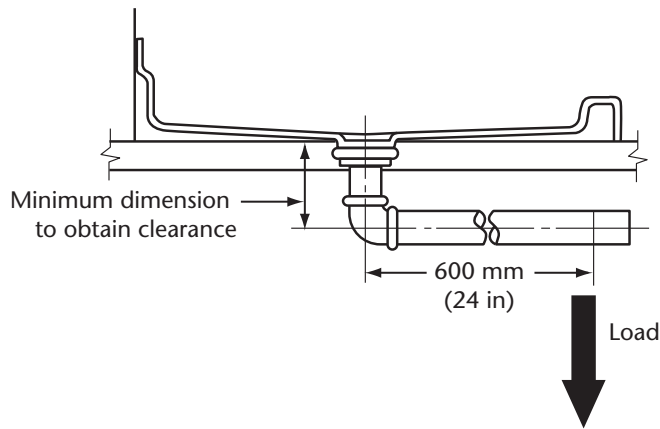
△

**Figure 7**  
**Minimum dimensions for bathtubs**

(See Clauses 4.4.1 and 4.4.3.)



**Figure 8**  
**Shower base thresholds**  
 (See Clauses 4.4.1 and 4.4.4.)



**Figure 9**  
**Waste fitting connection test**  
 (See Clause 5.6.1.)

# ***CSA Standards Update Service***

***CSA B45.5-11/IAPMO Z124-2011***

***October 2011***

**Title:** *Plastic plumbing fixtures*

**Pagination:** **55 pages** (xiii preliminary and 42 text), each dated **October 2011**

To register for e-mail notification about any updates to this publication

- go to **[www.ShopCSA.ca](http://www.ShopCSA.ca)**
- click on **E-mail Services** under **MY ACCOUNT**
- click on **CSA Standards Update Service**

The **List ID** that you will need to register for updates to this publication is **2421339**.

If you require assistance, please e-mail [techsupport@csa.ca](mailto:techsupport@csa.ca) or call 416-747-2233.

Visit CSA's policy on privacy at [www.csagroup.org/legal](http://www.csagroup.org/legal) to find out how we protect your personal information.



*CSA/IAPMO Standard*

*CSA B45.5-11/IAPMO Z124-2011*  
***Plastic plumbing fixtures***



**CANADIAN STANDARDS  
ASSOCIATION**

*® Registered trade-mark of Canadian Standards Association*



## Commitment for Amendments

This Standard is issued jointly by the Canadian Standards Association (CSA) and the International Association of Plumbing and Mechanical Officials (IAPMO). Amendments to this Standard will be made only after processing according to the Standards writing procedures of both CSA and IAPMO.

Published in October 2011 by Canadian Standards Association  
A not-for-profit private sector organization  
5060 Spectrum Way, Suite 100  
Mississauga, Ontario, Canada  
L4W 5N6  
1-800-463-6727 • 416-747-4044  
Visit the CSA Online Store at [www.ShopCSA.ca](http://www.ShopCSA.ca)

ISBN 978-1-55491-691-7

© Canadian Standards Association — 2011

All rights reserved. No part of this publication may be reproduced in any form whatsoever without the prior permission of the publisher.

International Association of Plumbing and Mechanical Officials (IAPMO)  
5001 East Philadelphia Street  
Ontario, California 91761-2816  
USA  
1-800-854-2766 • 1-909-472-4100  
Visit the IAPMO Standards Store at  
<https://publications.IAPMO.org/standards>  
Copyright © 2011 by International Association of Plumbing and Mechanical Officials

The 2011 edition of this Standard is being issued with an automatic addenda subscription service. The use of addenda allows revisions made in response to public review comments or committee actions to be published as necessary.

# Contents

CSA Technical Committee on Plumbing Fixtures	vii
IAPMO Main Standards Committee	ix
CSA/IAPMO Joint Harmonization Task Group on Plastic Plumbing Fixtures	xi
Preface	xii

## **0 Introduction** 1

## **1 Scope** 1

## **2 Reference publications** 2

## **3 Definitions** 3

## **4 General requirements** 4

4.1	General	4
4.1.1	Tolerances	4
4.1.2	Surface finish	4
4.1.3	Coated parts	4
4.1.4	Different materials	4
4.1.5	Accessible design fixtures	4
4.2	Waste fitting openings, drainage, and overflows	5
4.2.1	Openings and drainage	5
4.2.2	Overflows	5
4.3	Lavatories and sinks	5
4.3.1	Openings and mounting surfaces for supply fittings	5
4.4	Bathtubs and shower bases	6
4.4.1	Flanges	6
4.4.2	Slope to the waste outlet	6
4.4.3	Minimum dimensions for bathtubs	6
4.4.4	Shower base thresholds	6
4.4.5	Diameter, spacing, and grippable length of grab bars	6
4.4.6	Bathtubs with pressure sealed doors	6
4.5	Water closets	6
4.6	Urinals	6

## **5 Test requirements** 7

5.1	General	7
5.2	Load and rotation tests for grab bars and grip rails	7
5.2.1	Procedures	7
5.2.2	Water leakage test for grab bars and grip rails	7
5.2.3	Performance	7
5.3	Warpage tolerance test	7
5.3.1	Procedure	7
5.3.2	Performance	8
5.4	Surface examination test	8
5.4.1	Procedure	8
5.4.2	Performance	8
5.5	Subsurface test	8

5.5.1	Procedure	8
5.5.2	Performance	9
5.6	Waste fitting connection test	9
5.6.1	Procedure for bathtubs and shower bases	9
5.6.2	Procedure for other fixtures	9
5.6.3	Performance	9
5.7	Point impact load test	9
5.7.1	Procedures	9
5.7.2	Performance	10
5.8	Structural integrity tests	10
5.8.1	Load test for bathtub and shower seats	10
5.8.2	Load test for bathtub rims and bottoms and shower thresholds and bottoms	10
5.8.3	Area impact load test for bathtub and shower wall surrounds	12
5.8.4	Load test for bathtub and shower wall surrounds	12
5.8.5	Load test for unsupported bathtub areas	13
5.8.6	Load test for sinks	13
5.8.7	Load test for lavatories with integral tops and for wall-hung lavatories	14
5.8.8	Load test for floor-mounted water closet bowl rims	14
5.8.9	Load test for water closet tank lids	15
5.9	Radii load test for water closets, urinals, bathtubs, and showers	15
5.9.1	Procedure	15
5.9.2	Performance	15
5.10	Colourfastness test	15
5.10.1	Specimen	15
5.10.2	Conditions	15
5.10.3	Procedure	15
5.10.4	Performance	16
5.11	Stain resistance test	16
5.11.1	Procedure	16
5.11.2	Rating	17
5.11.3	Performance	17
5.12	Cleanability and wear tests	17
5.12.1	Wear test	17
5.12.2	Cleanability test	19
5.12.3	Performance	19
5.13	Ignitability test	19
5.13.1	General	19
5.13.2	Procedure	20
5.13.3	Performance	20
5.14	Cigarette test	20
5.14.1	Procedure	20
5.14.2	Performance	21
5.15	Chemical resistance test	21
5.15.1	Specimens	21
5.15.2	Procedure	21
5.15.3	Performance	21
5.16	Thermal shock resistance test	21
5.16.1	Specimen	21
5.16.2	Procedure	22
5.16.3	Performance	22
5.17	Water resistance test for bathtubs and showers	22
5.17.1	Specimens	22
5.17.2	Procedure	22
5.17.3	Performance	22

- 5.18 Field-installed tiling-flange seal test 23
  - 5.18.1 Procedure 23
  - 5.18.2 Performance 23
- 5.19 Overflow test 23
  - 5.19.1 Procedure 23
  - 5.19.2 Performance 23
- 5.20 Knife drop test (for kitchen and bar sinks only) 23
  - 5.20.1 Procedure 23
  - 5.20.2 Performance 24
- 5.21 Skillet drop test (for kitchen sinks only) 24
  - 5.21.1 Procedure 24
  - 5.21.2 Performance 24
- 5.22 Vibration test 24
  - 5.22.1 General 24
  - 5.22.2 Procedure 24
  - 5.22.3 Performance 24
- 5.23 Heated pan test (for kitchen sinks only) 24
  - 5.23.1 Procedure 24
  - 5.23.2 Performance 25
- 5.24 Hot wax test (for kitchen sinks only) 25
  - 5.24.1 General 25
  - 5.24.2 Procedure 25
  - 5.24.3 Performance 25
- 5.25 Tests for flexible core construction fixtures 25
  - 5.25.1 Resistance to fungi and bacteria growth 25
  - 5.25.2 Puncture resistance test 25
  - 5.25.3 Bonding test 26
  - 5.25.4 Water absorption test 26

## 6 Markings 27

- 6.1 General 27
- 6.2 Non-standard fixtures 27
- 6.3 Field-installed flanges 27
- 6.4 Packaging 27
- 6.5 Installation instructions 28

## Annexes

- A** (informative) — Unit conversion and rounding criteria 40
- B** (normative) — Water resistance test tank 41

---

## Tables

- 1** — Surface test requirements 28
- 2** — Scrub cycles 29
- 3** — Brush switching schedule for scrub test 29
- 4** — Thermal shock resistance test 29

---

## Figures

- 1** — Waste outlets dimensions 30
- 2** — Opening and mounting surface dimensions for standard 200 mm (8 in) deck fittings 31
- 3** — Opening and mounting surface dimensions for standard 200 mm (8 in) combination fittings 31
- 4** — Opening and mounting surface dimensions for standard 100 mm (4 in) centre-set fittings 32
- 5** — Opening and mounting surface dimensions for standard 200 mm (8 in) combination fittings 32
- 6** — Opening and mounting surface dimensions for single-mount supply fittings 33

- 7** — Minimum dimensions for bathtubs 33
- 8** — Shower base thresholds 34
- 9** — Waste fitting connection test 34
- 10** — Alternative load test for bathtub rims and bottoms 35
- 11** — Test for secondary loads on bathtub rims and bottoms and load test for unsupported bathtub areas 36
- 12** — Test for secondary loads on shower thresholds and bottoms 36
- 13** — Load test for lavatories with integral tops and for wall-hung lavatories 37
- 14** — Load test for floor-mounted water closet bowl rims 37
- 15** — Load test for water closet tank lids 38
- 16** — Wear test specimen 38
- 17** — Ignitability test 39

# ***CSA Technical Committee on Plumbing Fixtures***

<b>S. Rawalpindiwala</b>	Kohler Co., Kohler, Wisconsin, USA	<i>Chair</i>
<b>F. Lemieux</b>	Health Canada, Ottawa, Ontario	<i>Vice-Chair</i>
<b>R. Beck</b>	ICC Evaluation Service Inc., Birmingham, Alabama, USA	<i>Associate</i>
<b>J. Bouwer</b>	Euro Sales Inc., Elora, Ontario	
<b>R. Brown</b>	Franke Kindred Canada Limited, Midland, Ontario	
<b>S.L. Cavanaugh</b>	Cavanaugh Consulting, Burbank, California, USA	
<b>I.W. Chang</b>	Intertek, Coquitlam, British Columbia	<i>Associate</i>
<b>N. Dickey</b>	CSA International, Cleveland, Ohio, USA	<i>Associate</i>
<b>Y. Duchesne</b>	Régie du bâtiment du Québec, Québec, Québec	
<b>T.D. Ellison</b>	Cheffell Associates, Rockland, Ontario	
<b>K. Ernst</b>	Oakville Stamping & Bending Limited, Oakville, Ontario	
<b>A.U. Esteban</b>	Comisión Nacional del Agua, México, D.F., México	<i>Associate</i>
<b>F. Fernández</b>	TOTO USA, Inc., Ontario, California, USA	
<b>P. Georgopoulos</b>	City of Toronto, Toronto, Ontario	
<b>D. Gervais</b>	City of Windsor, Windsor, Ontario <i>Representing the Ontario Plumbing Inspectors Association</i>	
<b>D. Green</b>	National Research Council Canada, Ottawa, Ontario	
<b>J.C. Gunn</b>	John C. Gunn Consulting, Roches Point, Ontario	

<b>C. Hernández</b>	Plumbing Manufacturers Institute, Rolling Meadows, Illinois, USA	<i>Associate</i>
<b>R. Hildebrand</b>	Regional Municipality of Waterloo, Kitchener, Ontario	
<b>L. Himmelblau</b>	Chicago Faucet Company, Des Plaines, Illinois, USA	
<b>E. Ho</b>	IAPMO Research & Testing, Inc., Ontario, California, USA	<i>Associate</i>
<b>K.S. Hui</b>	Ontario Ministry of Municipal Affairs and Housing, Toronto, Ontario	
<b>J. Knapton</b>	SAIT Polytechnic, Calgary, Alberta	
<b>J.M. Koeller</b>	Koeller and Company, Yorba Linda, California, USA	
<b>N.M. Kummerlen</b>	Lorain, Ohio, USA	
<b>C.J. Lagan</b>	American Standard Brands, Piscataway, New Jersey, USA	
<b>B. Lagueux</b>	Saint-Nicolas, Québec <i>Consumer Representative</i>	
<b>J. Manente</b>	Region of Peel, Brampton, Ontario	<i>Associate</i>
<b>S.E. Martin</b>	International Code Council, Whittier, California, USA	<i>Associate</i>
<b>T.J. McCann</b>	Department of National Defence, Ottawa, Ontario	
<b>D. McNamara</b>	Franke Kindred Canada Limited, Midland, Ontario	<i>Associate</i>
<b>D. Orton</b>	NSF International, Ann Arbor, Michigan, USA	<i>Associate</i>
<b>S.A. Remedios</b>	Delta Faucet Company, Indianapolis, Indiana, USA	
<b>S. Rouleau</b>	CG Air Systèmes Inc., Sainte-Marguerite, Québec	<i>Associate</i>
<b>C.W. Trendelman</b>	Delta Faucet Company, Indianapolis, Indiana, USA	<i>Associate</i>
<b>L. Pilla</b>	Canadian Standards Association, Mississauga, Ontario	<i>Project Manager</i>

# ***IAPMO Main Standards Committee***

<b>S. Galayda</b>	Product Listing Services, Inc., Litchfield, Ohio, USA	<i>Chair</i>
<b>S. Rawalpindiwala</b>	Kohler Co., Kohler, Wisconsin, USA	<i>Vice-Chair</i>
<b>C. Arnold</b>	National Association of Home Builders, Washington, D.C., USA	
<b>J.A. Ballanco</b>	JB Engineering & Code Consulting, PC, Munster, Indiana, USA	
<b>B. Brody</b>	Safas Corp., Clifton, New Jersey, USA	
<b>S.L. Cavanaugh</b>	Cavanaugh Consulting, Burbank, California, USA	
<b>A. Ciechanowski</b>	NSF International, Ann Arbor, Michigan, USA	
<b>M. Clark</b>	NIBCO, Elkhart, Indiana, USA	
<b>L. Cox</b>	Structurlite Composites Consultants, Hebron, Ohio, USA	
<b>J.D. Dingman</b>	Underwriters Laboratories, Northbrook, Illinois, USA	
<b>G.S. Duren</b>	Code Compliance Inc., Kesyton Heights, Florida, USA	
<b>C.R. Graham</b>	Martech Enterprises, Thousand Oaks, California, USA	
<b>S. Hazzard</b>	American Society of Sanitary Engineering, Westlake, Ohio, USA	
<b>J.M. Koeller</b>	Koeller and Company, Yorba Linda, California, USA	
<b>C.J. Lagan</b>	American Standard Brands, Piscataway, New Jersey, USA	
<b>S.E. Martin</b>	International Code Council, Whittier, California, USA	
<b>L.A. Mercer</b>	Moen Incorporated, North Olmsted, Ohio, USA	

<b>S. Parkhurst</b>	SGS U.S. Testing Company Tulsa, Oklahoma, USA	
<b>S.A. Remedios</b>	Delta Faucet Company, Indianapolis, Indiana, USA	
<b>A.L. Scarano</b>	Yardley, Pennsylvania, USA	
<b>W.A. Schneider</b>	Containment Solutions, Inc., Conroe, Texas, USA	
<b>W.M. Smith</b>	Jay R. Smith Manufacturing Co., Montgomery, Alabama, USA	
<b>B. Taylor</b>	Taylor Industries, Inc., Parker Ford, Pennsylvania, USA	
<b>B. Tubaugh</b>	Josam, Edmond, Oklahoma, USA	
<b>W.C. Whitehead</b>	Whitehead Consulting Services, Danvers, Massachusetts, USA	
<b>A.I. Murra</b>	IAPMO Research & Testing Inc., Ontario, California, USA	<i>Secretary</i>

# ***CSA/IAPMO Joint Harmonization Task Group on Plastic Plumbing Fixtures***

<b>E. Ho</b>	IAPMO Research & Testing, Inc., Ontario, California, USA	<i>Co-Chair</i>
<b>S. Rouleau</b>	CG Air Systèmes Inc., Sainte-Marguerite, Québec	<i>Co-Chair</i>
<b>M.A. Banks</b>	Dupont Building Innovation, Buffalo, New York, USA	
<b>R. Brown</b>	Franke Kindred Canada Limited, Midland, Ontario	
<b>I.W. Chang</b>	Intertek, Coquitlam, British Columbia	
<b>N. Dickey</b>	CSA International, Cleveland, Ohio, USA	
<b>N.M. Kummerlen</b>	Lorain, Ohio, USA	
<b>F. Lemieux</b>	Health Canada, Ottawa, Ontario	
<b>S. Rawalpindiwala</b>	Kohler Co., Kohler, Wisconsin, USA	
<b>S.A. Remedios</b>	Delta Faucet Company, Indianapolis, Indiana, USA	
<b>A.I. Murra</b>	IAPMO Research & Testing, Inc., Ontario, California, USA	<i>Project Manager</i>
<b>L. Pilla</b>	Canadian Standards Association, Mississauga, Ontario	<i>Project Manager</i>

# Preface

This is the first edition of CSA B45.5/IAPMO Z124, *Plastic plumbing fixtures*.

This Standard replaces

- (a) CAN/CSA-B45.5-02, *Plastic plumbing fixtures*;
- (b) IAPMO/ANSI Z124.1.2-2005, *Plastic Bathtub and Shower Units*;
- (c) IAPMO/ANSI Z124.3-2005, *Plastic Lavatories*;
- (d) IAPMO/ANSI Z124.4-2006, *Plastic Water Closet Bowls and Tanks*;
- (e) IAPMO/ANSI Z124.6-2007, *Plastic Sinks*; and
- (f) IAPMO/ANSI Z124.9-2004, *Plastic Urinal Fixtures*.

This Standard is considered suitable for use for conformity assessment within the stated scope of the Standard.

This Standard was prepared by the CSA/IAPMO Joint Harmonization Task Group on Plumbing Fixtures, under the jurisdiction of the CSA Technical Committee on Plumbing Fixtures and the IAPMO Main Standards Committee. The CSA Technical Committee operates under the jurisdiction of the CSA Strategic Steering Committee on Water Management Products, Materials, and Systems. This Standard has been formally approved by the CSA Technical Committee and the IAPMO Main Standards Committee. This Standard was approved as an American National Standard by the American National Standards Institute on September 29, 2011.

October 2011

## CSA Notes:

- (1) Use of the singular does not exclude the plural (and vice versa) when the sense allows.
- (2) Although the intended primary application of this Standard is stated in its Scope, it is important to note that it remains the responsibility of the users of the Standard to judge its suitability for their particular purpose.
- (3) This publication was developed by consensus, which is defined by CSA Policy governing standardization — Code of good practice for standardization as “substantial agreement. Consensus implies much more than a simple majority, but not necessarily unanimity”. It is consistent with this definition that a member may be included in the Technical Committee list and yet not be in full agreement with all clauses of this publication.
- (4) To submit a request for interpretation of CSA Standards, please send the following information to [inquiries@csa.ca](mailto:inquiries@csa.ca) and include “Request for interpretation” in the subject line:
  - (a) define the problem, making reference to the specific clause, and, where appropriate, include an illustrative sketch;
  - (b) provide an explanation of circumstances surrounding the actual field condition; and
  - (c) where possible, phrase the request in such a way that a specific “yes” or “no” answer will address the issue.Committee interpretations are processed in accordance with the CSA Directives and guidelines governing standardization and are published in CSA’s periodical Info Update, which is available on the CSA website at <http://standardsactivities.csa.ca>.
- (5) CSA Standards are subject to periodic review, and suggestions for their improvement will be referred to the appropriate committee. To submit a proposal for change to CSA Standards, please send the following information to [inquiries@csa.ca](mailto:inquiries@csa.ca) and include “Proposal for change” in the subject line:
  - (a) Standard designation (number);
  - (b) relevant clause, table, and/or figure number;
  - (c) wording of the proposed change; and
  - (d) rationale for the change.
- (6) Attention is drawn to the possibility that some of the elements of this Standard may be the subject of patent rights. CSA is not to be held responsible for identifying any or all such patent rights. Users of this Standard are expressly advised that determination of the validity of any such patent rights is entirely their own responsibility.

## IAPMO Notes:

- (1) The use of the singular does not exclude the plural (and vice versa) when the sense allows.
- (2) This standard was developed in accordance with the IAPMO procedures accredited as meeting the criteria for American National Standards and it is an American National Standard. The IAPMO Standards Committee that approved this Standard was balanced to assure that individuals from competent and concerned interests had an opportunity to participate. During its development, this Standard was made available for public review, thus providing an opportunity for additional input from industry, academia, regulatory agencies, and the public at large.

- (3)** *This Standard was developed by consensus, which is defined as substantial agreement; consensus implies much more than a simple majority, but not necessarily unanimity. It is consistent with this definition that a member of the IAPMO Main Standards Committee can be included in the Committee list and yet not be in full agreement with all sections of this Standard.*
- (4)** *Although the intended primary application of this Standard is stated in its scope, it is important to note that it remains the responsibility of the users of the Standard to judge its suitability for their particular purpose.*
- (5)** *IAPMO Standards are subject to periodic review and suggestions for their improvement will be referred to the IAPMO Main Standards Committee. To submit a proposal for change to this Standard, you may send the following information to the International Association of Plumbing and Mechanical Officials, Attention Standards Department, 5001 East Philadelphia Street, Ontario, California, 91761, and include "Proposal for change" in the subject line:*
  - (a) standard designation (number);*
  - (b) relevant section, table, or figure number, as applicable;*
  - (c) wording of the proposed change, tracking the changes between the original and the proposed wording; and*
  - (d) rationale for the change.*
- (6)** *A request for interpretation should be clear and unambiguous. To submit a request for interpretation of this Standard, you may send the following information to the International Association of Plumbing and Mechanical Officials, Attention Standards Department, 5001 East Philadelphia Street, Ontario, California, 91761, and include "Request for interpretation" in the subject line:*
  - (a) the edition of the Standard for which the interpretation is being requested;*
  - (b) define the problem, making reference to the specific section and, when appropriate, include an illustrative sketch to explain the question;*
  - (c) provide an explanation of circumstances surrounding the actual field condition; and*
  - (d) when possible, phrase the request in such a way that a specific "yes" or "no" answer will address the issue.*
- (7)** *Interpretations are processed in accordance with IAPMO's accredited standards development procedures. IAPMO issues written replies to inquiries concerning interpretation of technical aspects of this Standard.*
- (8)** *IAPMO accepts responsibility for only those interpretations of this Standard issued in accordance with the accredited IAPMO policies and procedures, which precludes the issuance of interpretations by individuals.*
- (9)** *IAPMO does not "approve," "rate," or "endorse" any item, construction, proprietary device, or activity.*
- (10)** *IAPMO does not take any position with respect to the validity of any patent rights asserted in connection with any items mentioned in this Standard, and does not undertake to insure anyone utilizing this Standard against liability for infringement of any applicable patents, nor assumes any such liability. Users of this Standard are expressly advised that determination of the validity of any such patent rights, and the risk of infringement of such rights, are entirely their responsibility.*
- (11)** *Participation by federal agency representative(s) or person(s) affiliated with industry is not to be interpreted as government or industry endorsement of this standard.*
- (12)** *Attention is drawn to the possibility that some of the elements of this Standard may be the subject of patent rights. IAPMO is not to be held responsible for identifying any or all such patent rights. Users of this Standard are expressly advised that determination of the validity of any such patent rights is entirely their responsibility.*



# CSA B45.5-11/IAPMO Z124-2011

## *Plastic plumbing fixtures*

### **0 Introduction**

#### **0.1**

This harmonized Standard was developed in response to an industry request for a Standard for evaluation of plastic plumbing fixtures that would be acceptable for use in both Canada and the United States. Standards for plumbing fixtures made of other materials are also available or under development.

#### **0.2**

Harmonization activities for plastic plumbing fixtures Standards were undertaken in 2005 by a Joint Harmonization Task Group (JHTG) on Plumbing Fixtures, in which the CSA and IAPMO plumbing fixtures committees were equally represented. The responsibility for procedural matters and final approval of technical content was assumed by technical committees at higher levels within each SDO.

### **1 Scope**

#### **1.1**

This Standard covers plastic plumbing fixtures and specifies requirements for materials, construction, performance, testing, and markings.

#### **1.2**

This Standard covers the following plumbing fixtures:

- (a) bathtubs and combination tub/showers;
- (b) lavatories;
- (c) shower bases and shower stalls;
- (d) sinks:
  - (i) bar sinks;
  - (ii) kitchen sinks;
  - (iii) laundry sinks; and
  - (iv) service sinks;
- (e) urinals; and
- (f) water closets.

#### **1.3**

In this Standard, “shall” is used to express a requirement, i.e., a provision that the user is obliged to satisfy in order to comply with the standard; “should” is used to express a recommendation or that which is advised but not required; and “may” is used to express an option or that which is permissible within the limits of the standard.

Notes accompanying clauses do not include requirements or alternative requirements; the purpose of a note accompanying a clause is to separate from the text explanatory or informative material.

Notes to tables and figures are considered part of the table or figure and may be written as requirements.

Annexes are designated normative (mandatory) or informative (nonmandatory) to define their application.