



BSI Standards Publication

**Electronic Fee Collection (EFC)
— Interface definition between
DSRC-OBE and external in-
vehicle devices**

National foreword

This Published Document is the UK implementation of ISO/TS 16785:2014.

The UK participation in its preparation was entrusted to Technical Committee EPL/278, Intelligent transport systems.

A list of organizations represented on this committee can be obtained on request to its secretary.

This publication does not purport to include all the necessary provisions of a contract. Users are responsible for its correct application.

© The British Standards Institution 2014. Published by BSI Standards Limited 2014

ISBN 978 0 580 85575 7

ICS 03.220.01; 35.240.60

Compliance with a British Standard cannot confer immunity from legal obligations.

This Published Document was published under the authority of the Standards Policy and Strategy Committee on 30 November 2014.

Amendments issued since publication

Date	Text affected
------	---------------

TECHNICAL
SPECIFICATION

ISO/TS
16785

First edition
2014-11-01

**Electronic Fee Collection (EFC) —
Interface definition between DSRC-
OBE and external in-vehicle devices**

*Perception du télépéage — Définition de l'interface entre
l'équipement à bord à communications dédiées à courte portée
(DSRC-OBE) et les dispositifs externes embarqués*



Reference number
ISO/TS 16785:2014(E)

© ISO 2014



COPYRIGHT PROTECTED DOCUMENT

© ISO 2014

All rights reserved. Unless otherwise specified, no part of this publication may be reproduced or utilized otherwise in any form or by any means, electronic or mechanical, including photocopying, or posting on the internet or an intranet, without prior written permission. Permission can be requested from either ISO at the address below or ISO's member body in the country of the requester.

ISO copyright office
Case postale 56 • CH-1211 Geneva 20
Tel. + 41 22 749 01 11
Fax + 41 22 749 09 47
E-mail copyright@iso.org
Web www.iso.org

Published in Switzerland

Contents

	Page
Foreword	iv
Introduction	v
1 Scope	1
2 Normative references	2
3 Terms and definitions	3
4 Symbols and abbreviated terms	4
5 Tolling models with external in-vehicle devices	5
5.1 General.....	5
5.2 Applicable tolling services.....	6
5.3 Basic DSRC tolling.....	6
5.4 Mobile-assisted DSRC tolling.....	7
5.5 Universal tolling.....	8
6 Message sets	10
6.1 General.....	10
6.2 Payment means status.....	12
6.3 Payment fee.....	12
6.4 Account update.....	13
6.5 Compliance checking data (CCCAttributes).....	13
6.6 Localization data (LacData).....	13
7 Security aspects	13
7.1 General.....	13
7.2 OBE interface profile.....	14
Annex A (normative) Data type specification	15
Annex B (normative) Protocol Implementation Conformance Statement proforma	17
Annex C (informative) Mobile-assisted DSRC tolling in Korea	19
Annex D (informative) Other possible tolling models	22
Annex E (informative) Applicable ITS services	25
Bibliography	30

Foreword

ISO (the International Organization for Standardization) is a worldwide federation of national standards bodies (ISO member bodies). The work of preparing International Standards is normally carried out through ISO technical committees. Each member body interested in a subject for which a technical committee has been established has the right to be represented on that committee. International organizations, governmental and non-governmental, in liaison with ISO, also take part in the work. ISO collaborates closely with the International Electrotechnical Commission (IEC) on all matters of electrotechnical standardization.

The procedures used to develop this document and those intended for its further maintenance are described in the ISO/IEC Directives, Part 1. In particular the different approval criteria needed for the different types of ISO documents should be noted. This document was drafted in accordance with the editorial rules of the ISO/IEC Directives, Part 2 (see www.iso.org/directives).

Attention is drawn to the possibility that some of the elements of this document may be the subject of patent rights. ISO shall not be held responsible for identifying any or all such patent rights. Details of any patent rights identified during the development of the document will be in the Introduction and/or on the ISO list of patent declarations received (see www.iso.org/patents).

Any trade name used in this document is information given for the convenience of users and does not constitute an endorsement.

For an explanation on the meaning of ISO specific terms and expressions related to conformity assessment, as well as information about ISO's adherence to the WTO principles in the Technical Barriers to Trade (TBT) see the following URL: [Foreword - Supplementary information](#)

The committee responsible for this document is ISO/TC 204, *Intelligent transport systems*.

Introduction

Background and motivation

With regards to reassessing the present fuel tax schemes to cope with prevailing plug-in hybrid vehicle and electric vehicle or introducing congestion charging system to urban roads or inter-urban roads etc., the needs for expanding toll roads are becoming worthy of notice in the world.

In countries where Dedicated Short-Range Communication (DSRC)-based Electronic Fee Collection (EFC) systems were introduced for toll roads and have been operated widely, making their EFC equipment applicable to present non-toll roads, such as urban roads or inter-urban roads, becomes a significant issue to be considered and solved.

There are three cases of introducing EFC to cope with those situations:

- Case-1: DSRC-based EFC should be introduced to new toll roads, as well as present toll roads.
- Case-2: Autonomous EFC should be introduced to new toll roads and present toll roads as replacing.
- Case-3: DSRC-based EFC should be operated for present toll roads as they are, and autonomous EFC should be introduced to new toll roads.

In case of both Case-1 and Case-2, necessary interface definitions and test procedures are already covered by existing EFC standards. However, in Case-3, as shown in [Figure 1](#), current On-Board Equipment (OBE) used for DSRC-based EFC should be considered to be used for autonomous EFC covering new toll roads in keeping consistency with present toll roads.

DSRC-OBE should be expanded functionally by cooperating with external in-vehicle devices composed of a Global Navigation Satellite Systems (GNSS) module and/or a cellular module and/or other related modules; therefore, DSRC-OBE is possible to be reused for new EFC environment consisting of DSRC-based EFC and autonomous systems.

Consequently, an application interface definition between DSRC-OBE and external in-vehicle devices is essential and should be standardized.

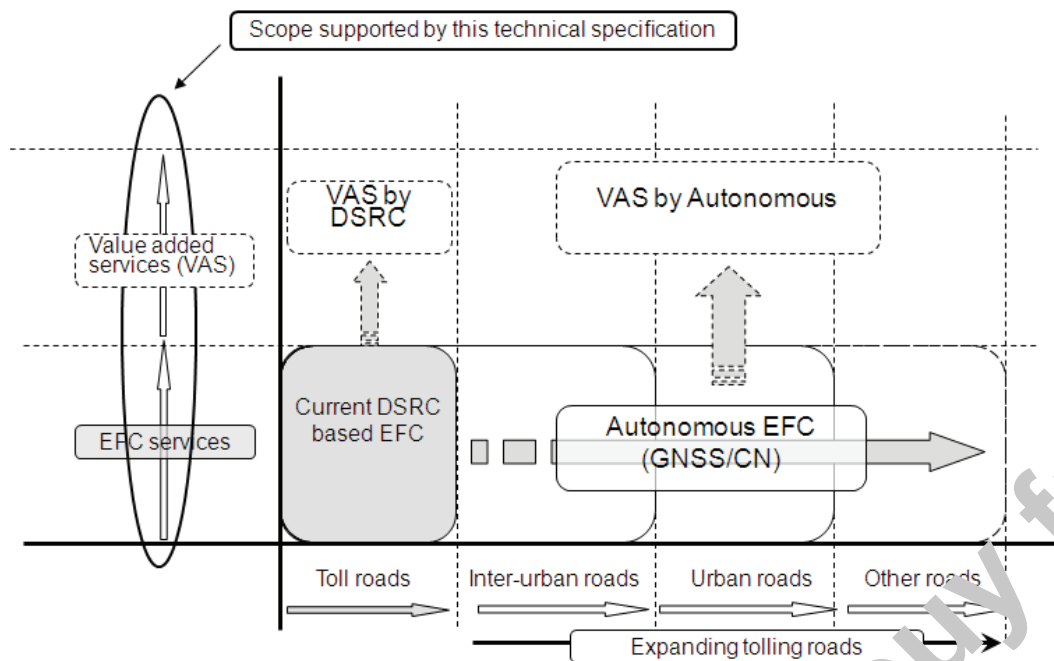

Figure 1 — Image of expanding toll roads and services (Case-3)

Purpose of this Technical Specification

This Technical Specification aims to make it possible for toll road operators to introduce autonomous systems to present non-toll roads by enhancing the functionalities of DSRC-On-Board Equipment (OBE) cooperating with external in-vehicle devices.

As listed below, this Technical Specification defines several tolling models, message sets, and data elements to cope with diversified EFC environment in the main body, as well as data type definition and Protocol Implementation Conformance Statement (PICS) proforma defined in [Annex A](#) and [Annex B](#) respectively. Finally, applicable ITS-services with cooperation of DSRC-OBE and external in-vehicle devices are listed in [Annex E](#) with an example for each of them. This Technical Specification aims at defining the following:

- tolling models with external in-vehicle devices (in main body);
- definitions of message sets and data elements;
- data type definition and PICS proforma (in [Annexes A](#) and [B](#));
- related example and applicable Intelligent Transport System (ITS) services (in [Annex E](#)).

Electronic Fee Collection (EFC) — Interface definition between DSRC-OBE and external in-vehicle devices

1 Scope

This Technical Specification defines an application interface between DSRC-based OBE and external in-vehicle devices to make DSRC-OBE applicable for diversified tolling environment.

The scope of this Technical Specification covers the following items (also shown in [Figure 2](#)):

- Definitions of the application interface between DSRC-OBE and external in-vehicle devices (including GNSS, cellular units, CAN interface, etc.).
- Definitions of message sets and data elements on the interface (based on a sets of base standards, such as ISO 14906:2011, ISO/TS 17575, ISO/TS 13141, ISO/TS 12813, and ISO/TS 25110).
- For use in autonomous EFC systems, as well as DSRC-based EFC.
- For use in diversified tolling environment (in toll roads, inner-urban, inter-urban, etc.).
- For use in every kind of DSRC-OBE (based on CEN, UNI, AR, JTA, and GB/T).

The following items are out of the scope for this TS:

- Definitions of hardware in the external in-vehicle devices such as GNSS modules, cellular modules, mobile devices, smartphones, etc.
- Definitions of physical interface between DSRC-OBE and external in-vehicle devices such as USB, Bluetooth, etc.
- Definition of any ITS service other than EFC.
- Definition of algorithms for authentication, as well as encryption, and key management.

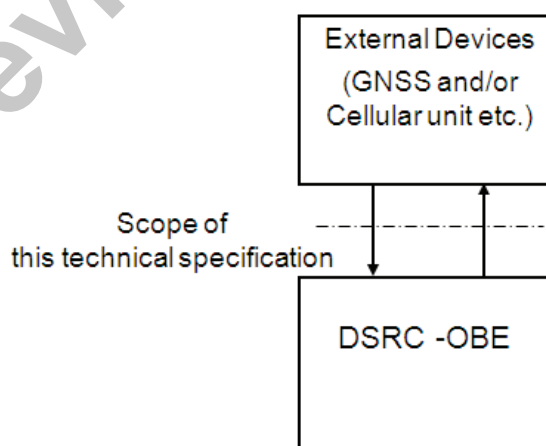

Figure 2 — Scope of this Technical Specification

Applicable DSRC-OBE

When standardizing an application interface between DSRC-OBE and external in-vehicle devices, external in-vehicle devices should be commonly applied for every kind of DSRC-based OBE as shown in [Figure 3](#).