



BSI Standards Publication

Dimensional tolerances of ferrite cores

National foreword

This Published Document is the UK implementation of IEC/TR 63090:2017.

The UK participation in its preparation was entrusted to Technical Committee EPL/51, Transformers, inductors, magnetic components and ferrite materials.

A list of organizations represented on this committee can be obtained on request to its secretary.

This publication does not purport to include all the necessary provisions of a contract. Users are responsible for its correct application.

© The British Standards Institution 2017
Published by BSI Standards Limited 2017

ISBN 978 0 580 96174 8

ICS 29.100.10

Compliance with a British Standard cannot confer immunity from legal obligations.

This Published Document was published under the authority of the Standards Policy and Strategy Committee on 31 August 2017.

Amendments/corrigenda issued since publication

Date	Text affected
------	---------------



IEC TR 63090

Edition 1.0 2017-05

TECHNICAL REPORT



Dimensional tolerances of ferrite cores

Currently in preview, click buy full version





THIS PUBLICATION IS COPYRIGHT PROTECTED
Copyright © 2017 IEC, Geneva, Switzerland

All rights reserved. Unless otherwise specified, no part of this publication may be reproduced or utilized in any form or by any means, electronic or mechanical, including photocopying and microfilm, without permission in writing from either IEC or IEC's member National Committee in the country of the requester. If you have any questions about IEC copyright or have an enquiry about obtaining additional rights to this publication, please contact the address below or your local IEC member National Committee for further information.

IEC Central Office
 3, rue de Varembe
 CH-1211 Geneva 20
 Switzerland

Tel.: +41 22 919 02 11
 Fax: +41 22 919 03 00
info@iec.ch
www.iec.ch

About the IEC

The International Electrotechnical Commission (IEC) is the leading global organization that prepares and publishes International Standards for all electrical, electronic and related technologies.

About IEC publications

The technical content of IEC publications is kept under constant review by the IEC. Please make sure that you have the latest edition, a corrigenda or an amendment might have been published.

IEC Catalogue - webstore.iec.ch/catalogue

The stand-alone application for consulting the entire bibliographical information on IEC International Standards, Technical Specifications, Technical Reports and other documents. Available for PC, Mac OS, Android Tablets and iPad.

IEC publications search - www.iec.ch/searchpub

The advanced search enables to find IEC publications by a variety of criteria (reference number, text, technical committee,...). It also gives information on projects, replaced and withdrawn publications.

IEC Just Published - webstore.iec.ch/justpublished

Stay up to date on all new IEC publications. Just Published details all new publications released. Available online and also once a month by email.

Electropedia - www.electropedia.org

The world's leading online dictionary of electronic and electrical terms containing 20 000 terms and definitions in English and French, with equivalent terms in 16 additional languages. Also known as the International Electrotechnical Vocabulary (IEV) online.

IEC Glossary - www.iec.ch/glossary

65 000 electrotechnical terminology entries in English and French extracted from the Terms and Definitions clause of IEC publications issued since 2002. Some entries have been collected from earlier publications of IEC TC 37, 77, 86 and CISPR.

IEC Customer Service Centre - webstore.iec.ch/csc

If you wish to give us your feedback on this publication or need further assistance, please contact the Customer Service Centre: csc@iec.ch.



IEC TR 63090

Edition 1.0 2017-05

TECHNICAL REPORT



Dimensional tolerances of ferrite cores

INTERNATIONAL
ELECTROTECHNICAL
COMMISSION

ICS 29.100.10

ISBN 978-2-8322-4349-7

Warning! Make sure that you obtained this publication from an authorized distributor.

CONTENTS

FOREWORD.....	3
INTRODUCTION.....	5
1 Scope.....	7
2 Normative references	7
3 Terms and definitions	7
4 Summary of dimensional tolerances of ferrite cores.....	7
4.1 General.....	7
4.2 Dimensional tolerances of E-cores.....	7
4.3 Dimensional tolerances of ring cores	7
4.4 Dimensional tolerances of ETD/EER-cores	11
4.5 Dimensional tolerances of planar ER-cores.....	13
5 Conclusion	15
Annex A (informative) Data of dimensional tolerances	16
A.1 E-core.....	16
A.2 Ring core	34
A.3 ETD/EER-core	43
A.4 Planar ER-core	49
Bibliography.....	55
Figure 1 – Cause-and-effect diagram of variations in dimension	6
Figure 2 – E-core.....	7
Figure 3 – Dimensional tolerances of each part of E-cores.....	9
Figure 4 – Ring core	10
Figure 5 – Dimensional tolerances of each part of ring cores	11
Figure 6 – ETD/EER-core	11
Figure 7 – Dimensional tolerances of each part of ETD/EER-cores	13
Figure 8 – Planar ER-core	14
Figure 9 – Dimensional tolerances of each part of planar ER-cores	15
Table 1 – IEC standards of ferrite core dimensions	5
Table 2 – Dimensional tolerances recommended for a new design of E-cores.....	8
Table 3 – Dimensional tolerances recommended for a new design of ring cores	10
Table 4 – Dimensional tolerances recommended for a new design of ETD/EER-cores	12
Table 5 – Dimensional tolerances recommended for a new design of planar ER-cores.....	14
Table A.1 – Dimensional tolerances of each part (<i>E-core</i>).....	16
Table A.2 – Dimensional tolerances of each part (<i>Ring-core</i>)	34
Table A.3 – Dimensional tolerances of each part (<i>ETD/EER-core</i>)	43
Table A.4 – Dimensional tolerances of each part (<i>Planar ER-core</i>)	49

INTERNATIONAL ELECTROTECHNICAL COMMISSION

DIMENSIONAL TOLERANCES OF FERRITE CORES

FOREWORD

- 1) The International Electrotechnical Commission (IEC) is a worldwide organization for standardization comprising all national electrotechnical committees (IEC National Committees). The object of IEC is to promote international co-operation on all questions concerning standardization in the electrical and electronic fields. To this end and in addition to other activities, IEC publishes International Standards, Technical Specifications, Technical Reports, Publicly Available Specifications (PAS) and Guides (hereafter referred to as "IEC Publication(s)"). Their preparation is entrusted to technical committees; any IEC National Committee interested in the subject dealt with may participate in this preparatory work. International, governmental and non-governmental organizations liaising with the IEC also participate in this preparation. IEC collaborates closely with the International Organization for Standardization (ISO) in accordance with conditions determined by agreement between the two organizations.
- 2) The formal decisions or agreements of IEC on technical matters express, as nearly as possible, an international consensus of opinion on the relevant subjects since each technical committee has representation from all interested IEC National Committees.
- 3) IEC Publications have the form of recommendations for international use and are accepted by IEC National Committees in that sense. While all reasonable efforts are made to ensure that the technical content of IEC Publications is accurate, IEC cannot be held responsible for the way in which they are used or for any misinterpretation by any end user.
- 4) In order to promote international uniformity, IEC National Committees undertake to apply IEC Publications transparently to the maximum extent possible in their national and regional publications. Any divergence between any IEC Publication and the corresponding national or regional publication shall be clearly indicated in the latter.
- 5) IEC itself does not provide any attestation of conformity. Independent certification bodies provide conformity assessment services and, in some areas, access to IEC marks of conformity. IEC is not responsible for any services carried out by independent certification bodies.
- 6) All users should ensure that they have the latest edition of this publication.
- 7) No liability shall attach to IEC or its directors, employees, servants or agents including individual experts and members of its technical committees and IEC National Committees for any personal injury, property damage or other damage of any nature whatsoever whether direct or indirect, or for costs (including legal fees) and expenses arising out of the publication, its use of, or reliance upon, this IEC Publication or any other IEC Publications.
- 8) Attention is drawn to the Normative references cited in this publication. Use of the referenced publications is indispensable for the correct application of this publication.
- 9) Attention is drawn to the possibility that some of the elements of this IEC Publication may be the subject of patent rights. IEC shall not be held responsible for identifying any or all such patent rights.

The main task of IEC technical committees is to prepare International Standards. However, a technical committee may propose the publication of a technical report when it has collected data of a different kind from that which is normally published as an International Standard, for example "state of the art".

IEC TR 63090, which is a Technical Report, has been prepared by IEC technical committee 51: Magnetic components, ferrite and magnetic powder materials.

The text of this technical report is based on the following documents:

Enquiry draft	Report on voting
51/1166/DTR	51/1186/RVDTR

Full information on the voting for the approval of this technical report can be found in the report on voting indicated in the above table.

This document has been drafted in accordance with the ISO/IEC Directives, Part 2.

The committee has decided that the contents of this document will remain unchanged until the stability date indicated on the IEC website under "<http://webstore.iec.ch>" in the data related to the specific document. At this date, the document will be

- reconfirmed,
- withdrawn,
- replaced by a revised edition, or
- amended.

A bilingual version of this publication may be issued at a later date.

IMPORTANT – The 'colour inside' logo on the cover page of this publication indicates that it contains colours which are considered to be useful for the correct understanding of its contents. Users should therefore print this document using a colour printer.

INTRODUCTION

This document shows the dimensional tolerances of ferrite cores that are generally used by ferrite core suppliers. As a reference, this is useful for ferrite core suppliers and users when they design ferrite cores and/or the components which use the ferrite cores.

IEC has published international standards regarding ferrite core dimensions and their tolerances, as listed in the Table 1, and core sizes in each core shape were chosen from industrial standards from Europe, Japan and USA. However, there are some cases that lack unity in the dimensional tolerances even if ferrite core dimensions are close.

Because many new sizes are still designed for the E, ETD/EER, planar ER and ring core, this document gives information about the dimensional tolerances for reference dimensions of each core shape.

Table 1 – IEC standards of ferrite core dimensions

IEC standard	Current standard
IEC 62317-1, <i>Ferrite cores – Dimensions – Part 1: General specification</i>	///
IEC 62317-2, <i>Ferrite cores – Dimensions – Part 2: Pot-cores for use in telecommunications, power supply, and filter applications</i>	///
IEC 62317-3, <i>Ferrite cores – Dimensions – Part 3: Half-pot cores (future standard)</i>	IEC 62323
IEC 62317-4, <i>Ferrite cores – Dimensions – Part 4: RM-cores and associated parts</i>	///
IEC 62317-5, <i>Ferrite cores – Dimensions – Part 5: EP-cores and associated parts for use in inductors and transformers</i>	///
IEC 62317-6, <i>Ferrite cores – Dimensions – Part 6: ETD-cores for use in power supplies</i>	///
IEC 62317-7, <i>Ferrite cores – Dimensions – Part 7: EER-cores</i>	///
IEC 62317-8, <i>Ferrite cores – Dimensions – Part 8: E-cores</i>	///
IEC 62317-9, <i>Ferrite cores – Dimensions – Part 9: Planar cores</i>	///
IEC 62317-10, <i>Ferrite cores – Dimensions – Part 10: PM cores (future standard)</i>	IEC 61247
IEC 62317-11, <i>Ferrite cores – Dimensions – Part 11: EC-cores for use in power supply applications</i>	///
IEC 62317-12, <i>Ferrite cores – Dimensions – Part 12: Ring cores</i>	///
IEC 62317-13, <i>Ferrite cores – Dimensions – Part 13: PQ-cores for use in power supply applications</i>	///
IEC 62317-14, <i>Ferrite cores – Dimensions – Part 14: EFD-cores for use in power supply applications</i>	///

Cause of variations in dimension

The shrinkage of <Ready to press> powders, the density of mouldings, the deformation of ferrite cores, etc., are considered as causes of variations in dimension.

They are gathered in the following cause-and-effect diagram in Figure 1.

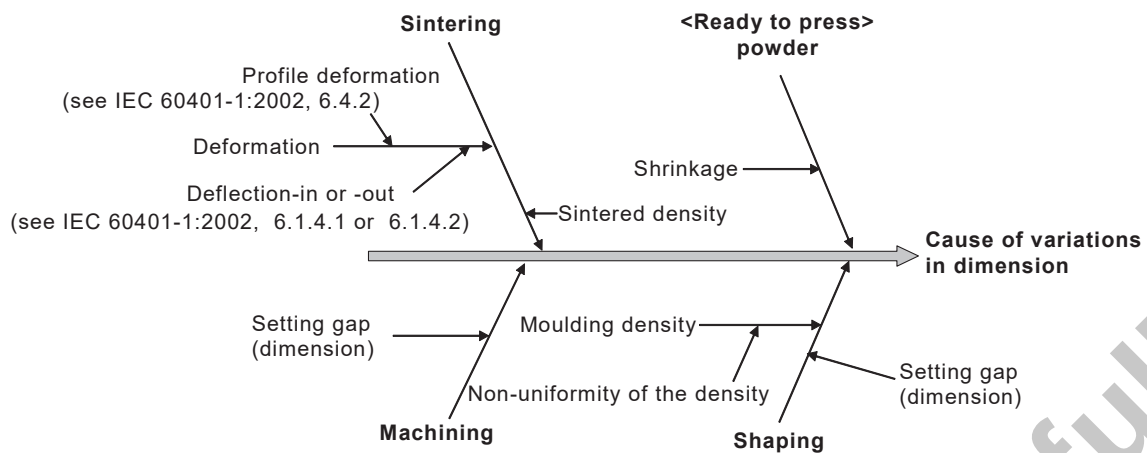

IEC

Figure 1 – Cause-and-effect diagram of variations in dimension

Consideration of the dimensional tolerance

The dimensional tolerance is considered according to the processing conditions, and the core part is classified into the following three conditions:

- decided according to the mould and sintering, or
- decided according to the press direction, or
- grinding direction.

DIMENSIONAL TOLERANCES OF FERRITE CORES

1 Scope

This document gives guidelines on the dimensional tolerances of ferrite cores. This document is considered as general information useful in the dialogue between ferrite core suppliers and users.

2 Normative references

There are no normative references in this document.

3 Terms and definitions

No terms and definitions are listed in this document.

ISO and IEC maintain terminological databases for use in standardization at the following addresses:

- IEC Electropedia: available at <http://www.electropedia.org/>
- ISO Online browsing platform: available at <http://www.iso.org/obp>

4 Summary of dimensional tolerances of ferrite cores

4.1 General

Figures 3, 5, 7 and 9 show the plots of the specifications of IEC standards and the catalogues of some ferrite core suppliers. The recommended boundary is the line connected by the supposed maximum points of the specifications of the IEC standards. Most of the points are under the recommended boundary.

4.2 Dimensional tolerances of E-cores

Figure 2 represents typical core geometry with the standard dimension nomenclature applied. Dimensional tolerances to recommend for a new design of E-cores are shown in Table 2. The scatter diagram of dimensional tolerances of each part of E-cores is shown in Figure 3. Dimensional tolerances of each part in the specifications of IEC standards and the catalogues of some ferrite core suppliers are shown in Table A.1.

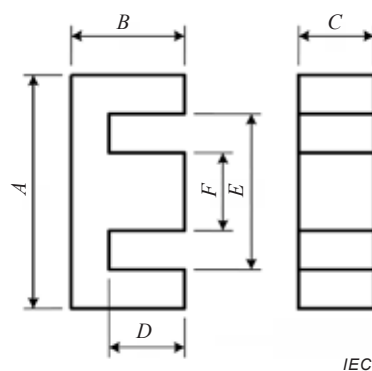

Figure 2 – E-core