



BSI Standards Publication

**Satellite signal distribution  
over a single coaxial cable —  
Second generation**

**National foreword**

This Published Document is the UK implementation of CLC/TS 50607:2013.

The UK participation in its preparation was entrusted by Technical Committee EPL/100, Audio, video and multimedia systems and equipment, to Subcommittee EPL/100/4, Cable distribution equipment and systems.

A list of organizations represented on this committee can be obtained on request to its secretary.

This publication does not purport to include all the necessary provisions of a contract. Users are responsible for its correct application.

© The British Standards Institution 2013.  
Published by BSI Standards Limited 2013

ISBN 978 0 580 83053 2  
ICS 33.060.40

**Compliance with a British Standard cannot confer immunity from legal obligations.**

This Published Document was published under the authority of the Standards Policy and Strategy Committee on 30 September 2013.

**Amendments/corrigenda issued since publication**

Date	Text affected
------	---------------

---

English version

## Satellite signal distribution over a single coaxial cable – Second generation

Distribution de signaux satellitaires sur un  
unique câble coaxial -  
Installations de seconde génération

Verteilen von Satellitensignalen über ein  
Koaxialkabel – Zweite Generation

This Technical Specification was approved by CENELEC on 2013-09-04.

CENELEC members are required to announce the existence of this TS in the same way as for an EN and to make the TS available promptly at national level in an appropriate form. It is permissible to keep conflicting national standards in force.

CENELEC members are the national electrotechnical committees of Austria, Belgium, Bulgaria, Croatia, Cyprus, the Czech Republic, Denmark, Estonia, Finland, Former Yugoslav Republic of Macedonia, France, Germany, Greece, Hungary, Iceland, Ireland, Italy, Latvia, Lithuania, Luxembourg, Malta, the Netherlands, Norway, Poland, Portugal, Romania, Slovakia, Slovenia, Spain, Sweden, Switzerland, Turkey and the United Kingdom.

# CENELEC

European Committee for Electrotechnical Standardization  
Comité Européen de Normalisation Electrotechnique  
Europäisches Komitee für Elektrotechnische Normung

**CEN-CENELEC Management Centre: Avenue Marnix 17, B - 1000 Brussels**

## Contents

Page

Foreword.....	4
Introduction .....	5
1 Scope.....	6
2 Normative references .....	6
3 Terms, definitions and abbreviations.....	7
3.1 Terms and definitions .....	7
3.2 Abbreviations .....	7
4 System architecture .....	8
5 SCIF control signals.....	10
5.1 DC levels .....	10
5.2 Method of the data bit signalling.....	12
6 Structure and format of the SCD2 messages.....	13
6.1 Backwards Compatibility to EN 50494 .....	13
6.2 Non-DiSEqC structure .....	13
6.3 Uni-directional operation.....	13
6.4 Bi-directional operation .....	13
7 SCD2 commands.....	13
7.1 ODU_Channel_change .....	13
7.2 ODU_Channel_change_PIN .....	15
7.3 ODU_UB_avail .....	15
7.4 ODU_UB_PIN.....	16
7.5 ODU_UB_inuse .....	17
7.6 ODU_UB_freq.....	18
7.7 ODU_UB_switches.....	19
8 Conventions.....	19
8.1 UB slots numbering .....	19
8.2 Numbering of satellite IF banks.....	20
9 Traffic collision management rules .....	20
9.1 General .....	20
9.2 Automatic detection of SCIF control signal failure.....	21
9.3 Pseudo-random repeat.....	21
Annex A (normative) Implementation rules .....	23
A.1 User interface .....	23
A.2 Installation impedance .....	23
A.3 Signal reflection and return loss in installations .....	24
A.4 Power supply of the SCIF.....	24
A.5 Remarks concerning power supply .....	25

<b>Figures</b>	<b>Page</b>
Figure 1 — General architecture of the single cable distribution.....	6
Figure 2 — General system operation and UB slot frequency mapping .....	8
Figure 3 — Installation example, system with reception of one orbital position (4 Satellite IF banks) by two receivers (2 UB slots) .....	9
Figure 4 — Installation example implementing the reception of two orbital positions (8 satellite IF banks) by four receivers (4 UB slots) .....	9
Figure 5 — Installation example implementing the reception of four orbital positions (16 satellite IF banks) for 12 receivers (12 UB slots) .....	10
Figure 6 — Signal sent by the receiver for uni-directional communication .....	11
Figure 7 — Signal sent by the receiver for bi-directional communication .....	12
Figure 8 — Bit signalling according to DiSEqC format.....	13
Figure 9 — SCIF control signal collision between two receivers and recovery mechanism .....	22
Figure A.1 — Solution for masking the impedance of the installation during the SCIF control signals .....	23
Figure A.2 — Implementation of an external power supply.....	24

<b>Tables</b>	<b>Page</b>
Table 1 -Timing for unidirectional communication .....	11
Table 2 -Timing for bidirectional communication .....	12
Table 3 – UB slot numbering .....	20

Currently in preview, click buy full version

## Foreword

This document (CLC/TS 50607:2013) has been prepared by CLC/TC 209 "Cable networks for television signals, sound signals and interactive services".

Attention is drawn to the possibility that some of the elements of this document may be the subject of patent rights. CENELEC [and/or CEN] shall not be held responsible for identifying any or all such patent rights.

Currently in preview, click buy full version

## Introduction

In EN 61319-1:1996/A11:1999, the interfaces for the control and command of the devices associated with the satellite receivers are described in the following clauses:

- Clause 4: Interfaces requirements for polarizer and polar switchers;
- Clause 5: Interfaces requirements for low-noise block converters (LNB).

In these clauses, analogue techniques are described for controlling the LNB and polar switchers.

In the DiSEqC™ Bus Functional Specification, the “Digital Satellite Equipment Control Bus” (called DiSEqC) is introduced as a single method of communication between the satellite and the peripheral equipment, using only the existing coaxial cables. The existing EN 50494 “Satellite signal distribution over a single coaxial cable in single dwelling installations” describes a system for distributing signals via single coaxial cable issued from different bands and polarisations to several satellite receivers. This specification is limited to 8 units per output of the Single Cable Interface and to 8 Satellite IF banks (bands, feeds, polarisations).

The second generation described in this Technical Specification is intended for single and multiple dwelling installations and includes the following enhancements compared to EN 50494:

- The number of demodulators is extended to a maximum of 2 units per output of the Single Cable Interface (hereafter referred to as SCIF) device.
- The system is scaled for a maximum number of 256 Satellite IF banks (bands, feeds, polarisations)
- The SCIF replies, which may be used during installation process, are also based on DiSEqC.
- Equipment according to this Technical Specification is downwards compatible to the specifications provided by EN 50494.

## 1 Scope

This Technical Specification describes:

- the system physical structure;
- the system control signals, which implement a set of messages using DiSEqC physical layer but not the DiSEqC message structure;
- the definition of identified configurations;
- the management of the potential collisions in the control signals traffic.

Figure 1 illustrates the physical system configuration considered in this Technical Specification.

Several satellite signal demodulators can receive signals from any of the input signal banks (Bank 1, Bank 2, ..., Bank M, with  $M \leq 256$ ) of the LNB or the switch. The signals selected by the demodulators (or receivers) are transported via a single cable to these demodulators (Receiver 1, Receiver 2, ..., Receiver N, with  $N \leq 32$ ).

To achieve these single cable distributions, the Single Cable Interface (SCIF, typically embedded in a LNB or a Switch) features some specific functions and characteristics.

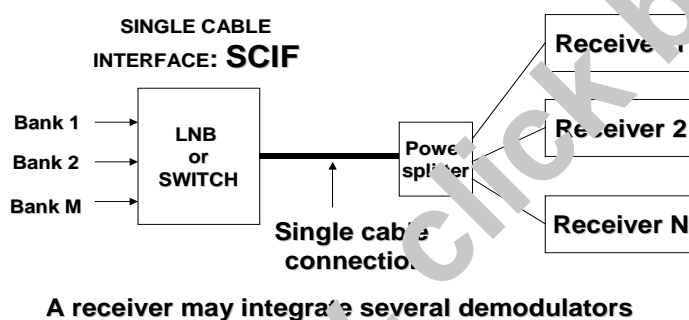

Figure 1 — General architecture of the single cable distribution

## 2 Normative references

The following documents, in whole or in part, are normatively referenced in this document and are indispensable for its application. For dated references, only the edition cited applies. For undated references, the latest edition of the referenced document (including any amendments) applies.

EN 50494	<i>Satellite signal distribution over single coaxial cable in single dwelling installations</i>
EN 60728-4	<i>Cable networks for television signals, sound signals and interactive services – Part 4: Passive wideband equipment for coaxial cable networks</i>
EN 61319-1:1996 + A11:1999	<i>Interconnections of satellite receiving equipment – Part 1: Europe (IEC 61319-1:1995)</i>
ISO/IEC 13818-1	<i>Information technology – Generic coding of moving pictures and associated audio information – Part 1</i>
DiSEqC™ Bus Functional Specification	Version 4.2, February 25, 1998 <a href="http://www.eutelsat.com/satellites/4_5_5.html">http://www.eutelsat.com/satellites/4_5_5.html</a>