



BSI Standards Publication

**Design of fastenings for use in concrete -
Redundant non-structural systems**

National foreword

This Published Document is the UK implementation of CEN/TR 17079:2018.

The UK participation in its preparation was entrusted to Technical Committee B/525/2, Structural use of concrete.

A list of organizations represented on this committee can be obtained on request to its secretary.

This publication does not purport to include all the necessary provisions of a contract. Users are responsible for its correct application.

© The British Standards Institution 2018
Published by BSI Standards Limited 2018

ISBN 978 0 580 91668 7

ICS 21.060.01; 91.080.40

Compliance with a British Standard cannot confer immunity from legal obligations.

This Published Document was published under the authority of the Standards Policy and Strategy Committee on 31 October 2018.

Amendments/corrigenda issued since publication

Date	Text affected
------	---------------

TECHNICAL REPORT

CEN/TR 17079

RAPPORT TECHNIQUE

TECHNISCHER BERICHT

September 2018

ICS 21.060.01; 91.080.40

English Version

Design of fastenings for use in concrete - Redundant non-structural systems

Conception-calcul des éléments de fixation pour
béton - Systèmes redondants non-structuraux

Bemessung der Verankerung von Befestigungen
in Beton - Redundante nicht-tragende Systeme

This Technical Report was approved by CEN on 9 April 2017. It has been drawn up by the Technical Committee CEN/TC 250.

CEN members are the national standards bodies of Austria, Belgium, Bulgaria, Croatia, Cyprus, Czech Republic, Denmark, Estonia, Finland, Former Yugoslav Republic of Macedonia, France, Germany, Greece, Hungary, Iceland, Ireland, Italy, Latvia, Lithuania, Luxembourg, Malta, Netherlands, Norway, Poland, Portugal, Romania, Serbia, Slovakia, Slovenia, Spain, Sweden, Switzerland, Turkey and United Kingdom.



EUROPEAN COMMITTEE FOR STANDARDIZATION
COMITÉ EUROPÉEN DE NORMALISATION
EUROPÄISCHES KOMITEE FÜR NORMUNG

CEN-CENELEC Management Centre: Avenue Marnix 17, B-1000 Brussels

Contents

Page

European foreword	iii
Introduction	iv
1 Scope	5
1.1 General	5
1.2 Type of fasteners	5
1.3 Fastener dimensions and materials	5
1.4 Fastener loading	6
1.5 Concrete strength	6
1.6 Concrete member loading	6
1.7 Concrete member dimensions	6
2 Normative references	6
3 Terms, definitions and symbols	7
3.1 Terms and definitions	7
3.2 Symbols	7
4 Basis of design	7
4.1 General	7
4.2 Attached element	7
4.3 Fixture	8
4.4 Loads at fixing points	8
4.5 Verification	8
5 Durability	8
Bibliography	9

European foreword

This document (CEN/TR 17079:2018) has been prepared by Technical Committee CEN/TC 250 “Structural Eurocodes”, the secretariat of which is held by BSI.

Attention is drawn to the possibility that some of the elements of this document may be the subject of patent rights. CEN shall not be held responsible for identifying any or all such patent rights.

Currently in preview, click buy full version

Introduction

EN 1992-4 provides a design method for fastenings (connection of statically determinate and statically indeterminate structural elements and non-structural elements to structural components), which are used to transmit actions to the concrete. EN 1992-4 assumes that with appropriate degree of reliability (see EN 1990) fasteners:

- sustain all actions and influences likely to occur during execution and use (ultimate limit state),
- do not deform to an inadmissible degree (serviceability limit state),
- remain fit for the use for which they are required (durability),
- are not damaged by accidental events to an extent disproportional to the original cause.

This Technical Report provides design guidance for post-installed fasteners for fixing statically indeterminate non-structural light weight systems with at least three fixing points. The fixing may be into normal weight concrete or precast prestressed hollow core slabs.

The proposed design model assumes that load transfer to adjacent fixing points takes place when excessive slip or failure of a fastener occurs under extreme conditions (e.g. large crack width). The suitability of the fasteners should be stated in a European Technical Product Specification for at least multiple use for non-structural applications in concrete (see e.g. assessment guideline developed under the CPD that is ETAG 001-6 [3]).

It is intended that this document is used in conjunction with EN 1992-4.

The numerical values for reliability parameters are recommended values and may be changed in a National Annex, if required. The recommended values apply:

- for post-installed fasteners in accordance with EN 1992-4:2018, 1.2;
- when the installation complies with the requirements of EN 1992-4:2018, 4.6 and Annex F.

1 Scope

1.1 General

This Technical Report provides design rules for fasteners used to connect statically indeterminate non-structural light weight systems (e.g. suspended ceilings, pipe work, ducting) to concrete members such as walls or floors (see [Figure 1](#)).

The proposed design model may be applied to post-installed mechanical and bonded anchors covered by EN 1992-4:2017, 1.2. Their suitability is given in a European Technical Product Specification.

The design rules assume the following:

- under extreme conditions (e.g. large crack width) excessive slip or failure of a fastener might occur;
- elements or systems are attached with at least three fixing points with one or more fasteners at each fixing point;
- where more than one fastener is used at a fixing point (MF, see [Figure 1](#)), only fasteners of the same type, size and length are used;
- the attached system is sufficiently stiff to transfer the load at any fixing point to adjacent fixing points without significantly impairing the performance characteristics of the system both at serviceability and ultimate limit states.

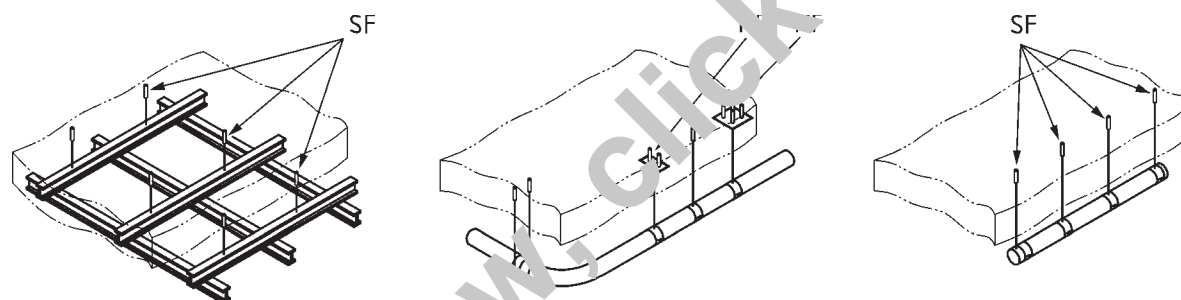

Key

- SF one fastener per fixing point
MF two or more fasteners per fixing point

Figure 1 — Statically indeterminate non-structural systems with one or more fasteners per fixing point — Examples

This Technical Report applies to non-structural applications in structures covered by EN 1992-1-1. In applications where special considerations apply, e.g. nuclear power plants or civil defence structures, modifications may be necessary.

This document does not cover the design of the fixture. The design of the fixture will be carried out to comply with the appropriate Standards.

1.2 Type of fasteners

Post-installed fasteners according to EN 1992-4.

1.3 Fastener dimensions and materials

EN 1992-4:2018, 1.3 applies with the following addition: In precast pre-stressed hollow core elements the minimum embedment depth may be reduced to a value to ensure proper functioning if placed in a flange (wall) of minimum thickness of 17 mm. In this case the minimum embedment depth and the