

Manual of Water Supply Practices

M49

Quarter-Turn Valves: Head Loss, Torque, and Cavitation Analysis

Third Edition



American Water Works
Association

M49

Quarter-Turn Valves: Head Loss, Torque, and Cavitation Analysis

Third Edition

Incorporates errata dated May 1, 2017



American Water Works
Association

Manual of Water Supply Practices—M49, Third Edition

Quarter-Turn Valves: Torque, Head Loss, and Cavitation Analysis

Copyright © 2001, 2012, 2017, American Water Works Association

All rights reserved. No part of this publication may be reproduced or transmitted in any form or by any means, electronic or mechanical, including photocopy, recording, or any information or retrieval system, except in the form of brief excerpts or quotations for review purposes, without the written permission of the publisher.

Disclaimer

The authors, contributors, editors, and publisher do not assume responsibility for the validity of the content or any consequences of its use. In no event will AWWA be liable for direct, indirect, special, incidental, or consequential damages arising out of the use of information presented in this book. In particular, AWWA will not be responsible for any costs, including, but not limited to, those incurred as a result of lost revenue. In no event shall AWWA's liability exceed the amount paid for the purchase of this book.

Project Manager: Melissa Valentine
Production: Studio Text
Cover Design: Melanie Yamamoto
Manuals Specialist: Sue Bach

Library of Congress Cataloging-in-Publication Data

Names: Bosserman, Bayard E., II, author. | Holstrom, John R., author. | American Water Works Association, editor.
Title: M49, quarter-turn valves : head loss, torque, and cavitation analysis / by B.E. Bosserman and John R. Holstrom.
Other titles: Quarter-turn valves
Description: Third edition. | Denver, CO : American Water Works Association, [2017] | Series: Manual M49 | Includes bibliographical references and index.
Identifiers: LCCN 2017001678 | ISBN 9781613006231
Subjects: LCSH: Water-pipes--Valves.
Classification: LCC TD491 .B67 2017 | DDC 620.1/5--dc23 LC record available at <https://lccn.loc.gov/2017001678>



This AWWA content is the product of thousands of hours of work by your fellow water professionals. Revenue from the sales of this AWWA material supports ongoing product development. Unauthorized distribution, either electronic or photocopied, is illegal and hinders AWWA's mission to support the water community.

ISBN-13 978-1-62576-206-1
eISBN-13 978-1-61300-406-7

Printed in the United States of America
American Water Works Association
6666 West Quincy Avenue
Denver, CO 80235-3098
awwa.org

Printed on
recycled paper

Contents

List of Figures, v	
List of Tables, vii	
Preface, ix	
Acknowledgments, xi	
Chapter 1 Introduction	1
Scope, 2	
New Definitions, MRST and AST, 2	
Diameter Assumptions, 3	
Quarter-Turn Valve Design, 4	
System Conditions, 9	
Definitions, 11	
References, 13	
Chapter 2 Valve Head Loss and Equivalent Resistance System Model.....	15
Discussion of Head Loss, Choking, and Cavitation, 15	
Definitions, 16	
Head Loss Calculations, 20	
Reducer Installations, 23	
Inherent and Installed Control Valve Flow Characteristics, 25	
Equivalent Resistance System Model, 26	
Variable Head Source Methodology, 31	
Energy Calculations, 32	
References, 35	
Chapter 3 Valve Torque	37
Discussion of Torque Calculations, 37	
Definition, 39	
Combining Torque Components, 42	
Seating and Unseating Torque, 46	
Packing and Hub Torque, 50	
Bearing Torque, 51	
Center of Gravity Torque, 55	
Hydrostatic Torque, 56	
Dynamic Torque, 58	
Shaft Offset or Eccentricity Torque, 60	
Other Components of Torque, 65	
System Characteristics, 72	
References, 76	
Chapter 4 Valve Cavitation	77
Definitions, 77	
Predicting Cavitation, 79	
Cavitation Calculation Methodology Example, 82	
Methods of Reducing Cavitation, 84	
References, 84	

Chapter 5 Valve Testing.....	85
Uncertainty, 85	
Testing Requirements, 86	
Test Procedure, 87	
Seating/Unseating Test Procedure, 93	
References, 95	
Chapter 6 Valve Applications.....	97
Actuator Sizing, 97	
Extended Bonnet Installation, 100	
Effects of Pipe Installations, 101	
Typical Range of Some Coefficients, 111	
Cautions, 113	
Summary, 114	
References, 115	
Appendix A, 117	
Appendix B, 119	
Appendix C, 121	
Index, 129	
List of Manuals, 133	

Figures

- 1-1 Valve disc, port, and pipe diameters, 4
- 1-2 Typical ball valve construction, 6
- 1-3 Typical butterfly valve construction, 7
- 1-4 Typical plug valve construction, 8
- 1-5 Typical rotary cone valve construction, 9
- 1-6 Butterfly valve offset designs, 10
- 1-7 Free discharge and reservoir inlet installations of BFVs, 11

- 2-1 Typical quarter-turn valve flow, differential pressure, cavitation, and choking graphical explanation, 17
- 2-2 Smaller-than-line-sized butterfly valve installation, 22
- 2-3 Reducer geometry, 23
- 2-4 Typical inherent valve characteristics, 26
- 2-5 Installed valve characteristics, 26
- 2-6 Equivalent resistance system model, 27
- 2-7 Example equivalent resistance system model diagram, 30
- 2-8 Graphical relationship between head loss and velocity, 31
- 2-9 Comparative operating costs by valve type, 34

- 3-1 Basic closure member design geometries, 40
- 3-2 Horizontal valve shaft in a horizontal pipe, 41
- 3-3 Seat-side, reverse, and shaft side direct flow direction orientations, 42
- 3-4 Active torque sign convention; positive values tend to close the valve, 42
- 3-5 Dynamic torque (T_d) and bearing torque (T_b) during valve closure, 45
- 3-6 One-, two-, and three-pump system operating curves, 45
- 3-7 Multiple-pump installation; example shown with butterfly valves, 46
- 3-8 Butterfly valve seating torque, 46
- 3-9 Plug valve seat perimeter and port area, 48
- 3-10 Butterfly valve packing and hub seal torque (T_p), 50
- 3-11 Bearing friction torque (T_b), 52
- 3-12 Center of gravity torque (T_{cg}), 55
- 3-13 Hydrostatic torque (T_h), 57
- 3-14 Dynamic torque (T_d) for a symmetrical disc butterfly valve, 59
- 3-15 Dynamic torque coefficient (C_d) graph for butterfly valves with symmetrical and offset closure members, 60
- 3-16 Dynamic torque (T_d) for a butterfly valve with symmetric and offset discs, 61
- 3-17 Total opening torque (T_{to}) for a 20-in. to 30-in. butterfly valve with symmetric and offset discs (in both flow directions), 61

- 3-18 Total opening torque (T_{to}) for a 78-in. to 96-in. butterfly valve with symmetric and offset discs (in both flow directions), 62
- 3-19 Total closing torque (T_{tc}) for a 20-in. to 30-in. butterfly valve with symmetric and offset discs, 62
- 3-20 Total closing torque (T_{tc}) for a 78-in. to 96-in. butterfly valve with symmetric and offset discs, 63
- 3-21 Shaft offset or eccentricity torque (T_{ecc}), 63
- 3-22 Bearing torque caused by closure member and shaft(s) weight orientation angles, 66
- 3-23 Center of gravity torque pipe angle definition, 68
- 3-24 Valve shaft and pipe orientation from vertical axis for center of gravity torque, 68
- 3-25 Valve shaft and pipe orientation from vertical axis for hydrostatic and bearing torque, 70
- 3-26 Example torque calculation summary graph, 75

- 4-1 Cavitation zones downstream of a butterfly valve disc, 78
- 4-2 Typical cavitation index levels and acceleration readings, 80
- 4-3 Flow rate and acceleration readings, 80
- 4-4 Typical cavitation index values for a 6-in. (150-mm) butterfly valve (reference upstream pressure from laboratory test = $P_{vt} = 70$ psi, vapor pressure from laboratory test = $P_{vt} = -12$ psi), 81
- 4-5 Example cavitation analysis summary graph, 83

- 5-1 Basic flow test system, 87
- 5-2 Butterfly valve test installation, 88

- 6-1 Typical actuator torque characteristic, 99
- 6-2 Typical ball valve construction, 99
- 6-3 Scotch yoke traveling nut actuator cutaway, 99
- 6-4 Link-and-lever traveling nut actuator cutaway, 100
- 6-5 Actuator sizing characteristic graph, 101
- 6-6 Typical extended bonnet construction, 102
- 6-7 Vertical elbow upstream of a butterfly or other quarter-turn valve preferred installation orientation, 104
- 6-8 Upstream expansion orientation preferences, 105
- 6-9 Upstream orifice orientation preferences, 106
- 6-10 Upstream reducer orientation preferences, 107
- 6-11 Upstream check valve preferred installation orientation, 107
- 6-12 Series-mounted valve preferred installation orientation, 108
- 6-13 Combined improper orientations, 108
- 6-14 Plug valve preferred installation orientation for suspended solids applications, 111

- B-1 Seating torque free body diagram, 119

Tables

- 2-1 Reducer and Increaser Calculations, 25
- 2-2 Valve Reducer, and Increaser Assembly Adjusted Flow Coefficients, 25
- 2-3 Head Loss Calculation Data for Constant Head Source Example, 30
- 2-4 Annual Pumping Cost Example Calculation, 33

- 3-1 Torque Component Category, 38
- 3-2 Torque Calculation Data for Constant Head Source Example, 75

- 4-1 Cavitation Calculation Data for Constant Head Source Example, 83

- 6-1 Typical Bearing Friction Coefficients, 112
- 6-2 Typical Packing Coefficients, 112
- 6-3 Typical Seating Coefficients, 112
- 6-4 Typical Full-Open Flow Coefficients, 113

- C-1 Nomenclature, terms, and symbols, 121
- C-2 Conversion of units, 128
- C-3 Abbreviations, 128

This page intentionally blank.

Currently in preview, click buy full version

Preface

The purpose of this manual is to present a recommended method for calculating operating torque, head loss, and cavitation for quarter-turn valves typically used in water works service. It is a discussion of recommended practice, not an American Water Works Association (AWWA) standard. The text provides guidance on generally available methods for using quarter-turn valves as well as their cavitation, flow, and torque characteristics. Questions about specific situations or applicability of specific valves and values should be directed to the manufacturers or suppliers. Information in this manual is useful for technicians and engineers who want a basic understanding of the calculations associated with the use and specification of quarter-turn valves. The valve torque, flow, and cavitation coefficients given are typical but generic values covering a variety of products. Actual flow, cavitation, or torque coefficients for a particular manufacturer's valve should be used in calculations for a specific valve and application to obtain the highest calculation accuracy.

The history of this manual is related to that of American National Standards Institute ANSI/AWWA C504, Standard for Rubber-Seated Butterfly Valves. Until the 1994 edition, ANSI/AWWA C504 included Appendix A, which described a recommended method of calculating torques for butterfly valves. This appendix was deleted from the 1994 and subsequent editions of the standard for several reasons. The AWWA Standards Council directed that standards documents should not contain appendixes; appendix text should either be moved to the main body of the standard or be made into a separate, stand-alone document. Members of the committee for ANSI/AWWA C504 at the time were concerned that the existing text of Appendix A no longer represented the current state of knowledge concerning methods for calculating torques for butterfly valves. In 1993, a subcommittee was established to rewrite Appendix A as a separate manual incorporating the state-of-the-art theory for calculating torque and head loss values for butterfly valves. The second edition of the manual expanded the introduction and some equations, added torque sign conventions, added double-offset disc design variables and calculations, added equations for eccentricity torque, added metric units and equivalents, consolidated the nomenclature, and corrected some errors. This third edition manual broadens the application of these methods to include other quarter-turn valves such as ball, plug, and rotary cone valves.

Manual M49 refers to AWWA standards available for purchase from the AWWA Bookstore. Manufacturers graciously provided valve illustrations and other documentation. AWWA does not endorse any manufacturer's products, and the names of the manufacturers have been removed from the material provided.

This page intentionally blank.

Acknowledgments



The AWWA Standards Council Committee for Butterfly Valves developed this manual with input from the Ball & Plug Valve Committees. The members listed below served on the Butterfly Valve Committee at the time the manual was approved. .

M. MacConnell, Chair, Metro Vancouver, Canada

User Members

S. Carpenter, San Diego County Water Authority, Escondido, Calif.
D.W. Coppes, Massachusetts Water Resources Authority, Chelsea, Mass.
S. Hattan, Tarrant Regional Water Dist., Ft. Worth, Texas
V.Q. Le, Los Angeles Water & Power, Los Angeles, Calif.
M. MacConnell, Metro Vancouver, Burnaby, BC, Canada
P.J. Ries, Denver Water, Denver, Colo.
S.Y. Tung, City of Houston, Houston, Texas

General Interest Members

A. Ali, ADA Consulting Ltd., Surrey, B.C.
M.D. Bennett, MWH, Cleveland, Ohio
B.E. Bosserman, Mission Viejo, Calif.
J. W. Green, Lockwood, Andrews & Newnam, Inc., Oakbrook Terrace, Ill.*
J. Hebenstreit, UL LLC, Northbrook, Ill.
F.L. Hinker, Santa Rosa, N.M.
M.C. Johnson, Utah State University, Water Research Lab, Logan, Utah
T. Jordan, HDR Inc., Denver, Colo.
T.J. McCandless,† American Water Works Association, Denver, Colo.
D. Middleton, AECOM, Wakefield, Mass.*
J.N. Nakashima, Lockwood, Andrews & Newnam, Inc., Oakbrook Terrace, Ill.
W. Rahmeyer, Utah State University, Water Research Lab, Logan, Utah*
U. Sant, AECOM, Dallas, Texas
R.A. Ward, Tighe & Bond, Westfield, Mass.

Producer Members

A. Abouelleil, Henry Pratt Company, Aurora, Ill.
S. Allen, Bray Valves, Jonesboro, Ariz.
J.V. Ballun, Val-Matic Valve & Manufacturing Corp., Elmhurst, Ill.
K.R. Graeff, Rodney Hunt Company, Orange, Mass.*
T.A. Hartman, Hartman Valve Corp., St. Louis, Mo.

* Alternate

† Liaison

H. Herold, VAG, Mannheim, Germany
J.R. Holstrom,* Sub-committee chair, Val-Matic Valve & Manufacturing Corp., Elmhurst, Ill.
K. Johnson, M&H Valve Company, Anniston, Ala.
A.W. Libke, DeZURIK, Sartell, Minn.
R. Tschida,* DeZURIK, Sartell, Minn.
J.H. Wilber, American AVK, Littleton, Colo.
D. Woollums,* Mueller Group, Chattanooga, Tenn.

The AWWA Standards Council Subcommittee for Addition of Ball and Plug Valves assisted in the development of this manual. The members listed below served on the subcommittee at the time the manual was approved.

John R. Holstrom, Subcommittee Chair, Elmhurst, Ill.

A. Abouelleil, Henry Pratt Company, Aurora, Ill.
*S.A. Bach**, American Water Works Association, Denver, Colo.
D.E. Burczynski, Kennedy Valve, Elmira, N.Y.
S. Hattan, Tarrant Regional Water District, Ft. Worth, Texas
H. Herold, VAG, Mannheim, Germany
F.L. Hinker, Santa Rosa, N.M.
J.R. Holstrom, Val-Matic Valve & Manufacturing Corp., Elmhurst, Ill.
K. Johnson, M&H Valve Company, Anniston, Ala.
M.C. Johnson, Utah State University, Water Research Lab., Logan, Utah
R. Kilborn, Town of Gilbert NWTP, Gilbert, Ariz.
A.W. Libke, DeZURIK-APCO, Sartell, Minn.
R. Looney, American AVK Company, Minden, Nev.
J.D. Martin, American R&D, Anniston, Ala.
S. Notch, Gilbert, Ariz.
T. O'Shea, DeZURIK-APCO, Willamette Division, Schaumburg, Ill.
J.E. Pearman, Ross Valve MFG. Company, Winchendon, Mass.
W.H. Peffley, Crawford, Murphy & Tilly, Springfield, Ill.
P. Savalia, Henry Pratt Company, Aurora, Ill.
G.E. Slaughter, Victaulic Company, Olathe, Kan.
*M. Valentine**, American Water Works Association, Denver, Colo.
J.H. Wilber, American AVK, Littleton, Colo.

* Staff

Introduction

Head loss, torque, and cavitation are important considerations in the selection and sizing of quarter-turn valves in water systems. Quarter-turn valve components must be able to withstand the forces and torques generated during use, and the actuator must drive and seat the valve. The head loss developed across any valve adds to the energy costs of a pumping system. Cavitation can damage a valve or adjacent piping if not controlled.

The topics in this introductory chapter include an explanation of basic quarter-turn valve design elements and their role in predicting operating head loss, torque, and cavitation. Prior editions limited this manual of standard practice to butterfly valves (BFV). This edition has been expanded to include information on other quarter-turn valves, including ball (BV), rotary cone (RCV), and eccentric plug valves (PV). Many of the included illustrations are targeted toward BFVs but are generally applicable to all the valves of this scope.

Head loss characteristics must be known to predict valve operating torque, and system designers also use these data to size a control valve, calculate pump head requirements, and evaluate the energy costs associated with the head loss across the valve in pumping applications. Valve torque is calculated to allow proper actuator sizing and to provide assurance that the valve components can withstand the internal forces produced by the fluid flow and pressure.

Cavitation is analyzed to avoid undesirable sound and vibration and to prevent damage to the valve and adjacent piping. Cavitation data are determined by flow testing. Values for the range of valve angles are helpful in predicting if cavitation will occur in a given application.

Head loss, torque, and cavitation vary with a valve's position (angle of opening). These characteristics also depend on the geometry of the valve body and closure member as well as the characteristics of the system in which the valve is installed. Flow testing procedures of a valve requires a smooth, undisturbed flow upstream and downstream of the valve, such as that produced by a run of straight, constant-diameter pipe. Although variation from this ideal condition has an effect on valve head loss and torque, these conditions are the benchmark and basis for analysis. Flow disturbances caused by piping configuration, such as elbows, reducers, or other valves within a distance less than eight times the diameter upstream of the valve, may require further review by applying the recommendations given in chapter 6.

Coefficients provided by the quarter-turn valve manufacturer may be used to calculate the head loss and torque as described in this manual of standard practice, provided that the data are determined on the basis of testing methods described in chapter 5. The typical coefficients provided in this manual are presented only for illustrative and approximation purposes. Information from the valve test data or the manufacturer is needed before calculations can be performed for a specific valve in a specific use with high accuracy. However, generalized or typical information will assist in determining the applicability or sensitivity of some characteristics for valve type selection and for most system design considerations.

The closure members of this manual of standard practice are typically referred to as the ball, disc (BFV), cone, or plug. This manual of standard practice may refer to a general closure member or to one specific design. International and European standards will also use the term *obturator* for the closure member.

SCOPE

The fluid flow and torque calculations are based on water or wastewater flow and do not specifically relate to other liquids or gases. The adjustments for application to other fluids can be found in other texts on fluid mechanics. This manual of standard practice covers round or circular BVs and BFVs within the scopes of AWWA and American National Standards Institute (ANSI) standards ANSI/AWWA C504-15, ANSI/AWWA C507-15, and ANSI/AWWA C516-14 with essentially full-ported designs in which the port diameter and closure member diameter are close to the nominal pipe size (NPS) or nominal diameter (in inches or millimeters). This includes BFVs in sizes 3 in. (75 mm) and larger and BVs in sizes 6 in. (150 mm) through 60 in. (1,500 mm).

This manual of standard practice also covers PVs that have round or oblong ports and are available with either full or reduced port areas within the scope of ANSI/AWWA C517-09. Reduced port areas are generally greater than 75 percent of full pipe area.

Rotary cone valves in sizes 6 in. thru 84 in. and pressure ratings of 125 cold working pressure (CWP) or 275 CWP in cast- or ductile-iron construction or ANSI Classes 150 and 300 in steel construction are often used in this industry and referenced in other AWWA manuals of standard practices, such as M44. This valve type does not have an AWWA standard devoted to design and construction. This type of valve is also included in this manual of standard practice.

Some manufacturers produce valves that are configured as three-way and/or four-way valves, which have three or four connection ports and require special considerations not included in this manual of standard practice. The valves covered are of the two-way (two end connections, on-off or throttling) configuration. For all of these valves, it is important to use the matching data for the valve design of interest.

NEW DEFINITIONS, MRST AND AST

For purposes of clarity and understanding, many of the AWWA quarter-turn valve standards are now referring to the operating torque requirements of the valves as two different terms. These are actuator sizing torque (AST) and minimum required shaft torque (MRST), and their definitions appear later in this chapter. These are not to be considered as single values but a series of values (or curves) that vary with valve position. In some cases, one or two (break and/or break and run) conservative or bounding values may be used throughout the entire valve stroke, but in many cases, values at 10°, 5°, or fewer degree increments of valve travel are necessary. The torque predictions of this manual of standard practice provide the most probable operating torque requirements for a valve when

operated under the system conditions analyzed. This total operating torque is referred to as the MRST. Depending on the valve type, actuator standard, or manual of standard practice and the valve's application (on-off or modulating), the MRST is multiplied by an application factor (AF) to obtain an AST ($AST = MRST \times AF$). This is also calculated at many valve positions to correctly size the actuator. See the valve or actuator standards for the application factors to be used.

The actuator sizing additional torque margin, allowances for in-service degradation, and/or safety factors for power (i.e., electric motor, cylinder, or vane) actuators are provided in other ANSI/AWWA standards and included in the AFs and other sizing requirements of the product standard.

DIAMETER ASSUMPTIONS

For the valve shaft diameter, valves meeting ANSI/AWWA C504-15 have the minimum shaft diameters given in the standard. ANSI/AWWA C516-14, ANSI/AWWA C507-15, and ANSI/AWWA C517-09 do not provide minimum shaft diameters. It is always best to obtain the shaft diameter by measurement or from the manufacturer's documentation.

Many sources are available for quarter-turn valve flow and torque coefficients. These include valve engineering handbooks; published research papers; and valve supplier manuals, catalogues, or bulletins. The manufacturer generally publishes flow coefficients (i.e., C_v , C_{vm} , or K) for most valves. Some manufacturers consider the torque coefficients (C_t) to be proprietary information and may not publish these data.

Much existing data were developed before published standardization methods, and investigators may have based their calculations on different valve diameter measurements. The major valve diameters include NPS, approach pipe inside diameter, valve port diameter, valve seat diameter, and valve closure member diameter (see Figure 1-1). Also, various publications use slight variations of these first-principles equations or use different units of measure. The user is cautioned to evaluate and convert such data to the proper format and units of measure. For instance, some BFV manufacturers provide a dynamic torque coefficient for use in the formula, $T_d = C_1 \times \Delta P$. When equated to the basic formula used herein, $T_d = C_t \times D^3 \times \Delta P$, it follows that $C_1 = C_t \times D^3$ or $C_t = C_1/D^3$.

If the data were developed on the basis of a BFV disc diameter and the prediction calculations used the nominal diameter, there will be a larger uncertainty in the results than if the disc diameter were used. This manual of standard practice gives direction on what diameter should be used for standardization, consistency, uncertainty, and/or conservatism purposes. However, for many good engineering reasons, much of the older data does not conform to these guidelines. In many instances, the exact approach pipe inside diameter, valve port diameter, and/or valve closure member diameter are not known at the time the calculation is performed. This forces the designer to assume a conservative diameter with greater uncertainty in the results.

For the valves within the scope of this manual of standard practice, the approach pipe inside diameter, valve port diameter, and valve closure member diameter are almost always equal to or less than the valve's nominal diameter when using US customary dimensions. Therefore, the use of the nominal pipe size (NPS) diameter as the diameter in torque prediction calculations will often provide a conservatively high torque value (as the diameter appears in the numerator of the equations). The nominal diameter of the valve may be used in these prediction calculations in lieu of the approach pipe inside diameter, valve port diameter, or valve disc diameter as specified with the understanding that the torque results have a higher uncertainty and are generally greater than a more precise evaluation. In all cases, if the diameter basis on which the data are based is known, the use of the same variable provides the highest-accuracy prediction.

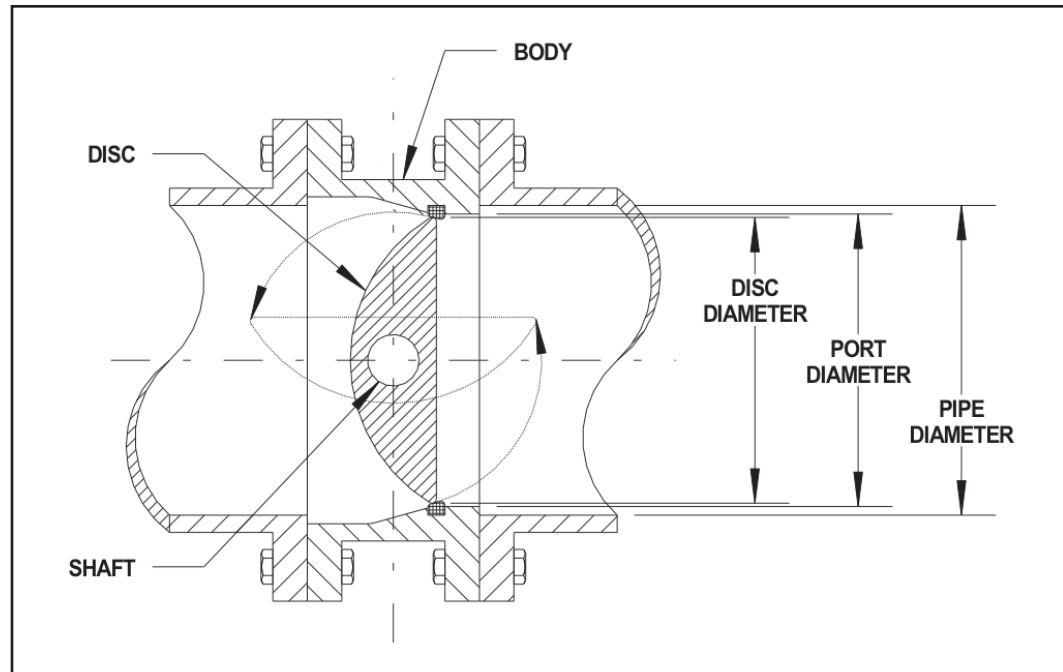

Figure 1-1 Valve disc, port, and pipe diameters

The flow coefficients, C_v and K , and testing and data collection methods that follow are those prescribed in the International Society of Automation (ISA) standard ANSI/ISA S75.02.01-2008, and are based on the test pipe inside diameter. This methodology does use two slight variations from the ANSI/ISA S75.02.01-2008 in that this practice subtracts the piping loss from the test data to obtain net (valve-only) coefficient values versus the gross (as measured, including pipe loss) values and the valve shaft axis orientation during the test. See chapter 5 for more detail.

QUARTER-TURN VALVE DESIGN

In general, valves may be classified as either linear operation or rotary operation. Linear-operating valves include slide gate, gate, globe, needle, and diaphragm valves. Rotary-operation valves include the BVs, BFVs, cone valves, and PVs in this manual of standard practice. As the full travel of many rotary-operation valves approximates a 90° rotation, they are often referred to as quarter-turn valves even though travel may be significantly more or less than 90° or a quarter turn. The quarter-turn valve is a versatile component for use with both shutoff and throttling in water systems. Quarter-turn valves are commonly supplied for the water industry in accordance with ANSI/AWWA C504-15, Standard for Rubber-Seated Butterfly Valves; ANSI/AWWA C507-15, Standard for Rubber-Seated Ball Valves 6 In. Through 60 In. (150 mm Through 1,500 mm); ANSI/AWWA C516-14, Standard for Large-Diameter Rubber-Seated Butterfly Valves Sizes 78 in. (2,000 mm) and Larger; or ANSI/AWWA C517-09, Standard for Resilient-Seated Cast-Iron Eccentric Plug Valves. As shown in Figures 1-2 through 1-5, these valves consist of a ball, cone, disc, or plug (closure member) supported in the body with a shaft, two stub shafts, or closure member trunnions and bearings. The quarter-turn operation is accomplished with a manual or power actuator connected to one shaft that penetrates the valve body and mounts to the exterior. Valves may have either metallic or elastomeric (rubber or plastic) seats.

Flow is controlled by positioning the closure member between 0° (0 percent, closed) to the full open (100 percent to approximately 90°) positions. The approximate effective throttling range for quarter-turn valves is 15° to 75° open (or 15 percent to 85 percent), but the range can vary based on application and valve design. Throttling at the lower angles (<15° or 15 percent) may cause erosion due to excessive local velocities or cavitation. Some valves are available with optional throttling or cavitation-reducing trim to extend the control range. See chapter 4 for discussions of cavitation. Throttling at the higher angles may provide limited control, because the valve has little effect on the system flow in many applications.

AWWA Ball Valve Design

AWWA BVs are characterized by the following design elements (see Figure 1-2):

- They primarily consist of a bored spheroidal closure member (obturator/ball) that rotates roughly a quarter turn on a shaft or trunnion within the valve body.
- Ports are full nominal size (US customary) and unobstructed. (Note: Non-AWWA valves may have reduced ports.)
- Closure member (ball) may be shaft- or trunnion-mounted within the body. (Note: Non-AWWA valves may have a floating ball that is supported by the seats.)
- Closure member (ball), when symmetrically mounted, is position-seated and does not close tighter by increasing the shaft torque at the seated position.
- Closure member (ball), if eccentrically mounted, may be either position- or torque-seated. The seat seal will be tightened by increasing the shaft torque against the seat.
- Bodies may be one-, two-, three-, or four-piece construction.
- Seats may be metallic-to-metallic or metallic-to-elastomeric.
- BVs may be single- or double-seated.
- In double-seated valves, the downstream seat often provides the primary closure seal.
- They are often used in pump control service to control surges and may act as a power-operated check valve.
- In pump control service, a single-seated BV should be installed to seal tightest against system reverse flow, not pumped flow. (This generally places the seat end of the valve toward the pump.)
- They offer good flow control with a near equal percentage inherent valve characteristic.
- The full diameter circular port offers the lowest possible full open head loss.
- The unobstructed full open flow path does not produce cavitation or vibration.

AWWA Butterfly Valve Design

AWWA BFs are characterized by the following design elements (see Figure 1-3):

- They primarily consist of a circular closure member (obturator/disc) that rotates about a quarter turn on a shaft within the valve body.
- Typically these valves have ports that are relatively close to full nominal size of pipe inside diameter.
- Seats may be metallic-to-elastomeric or metallic-to-metallic.

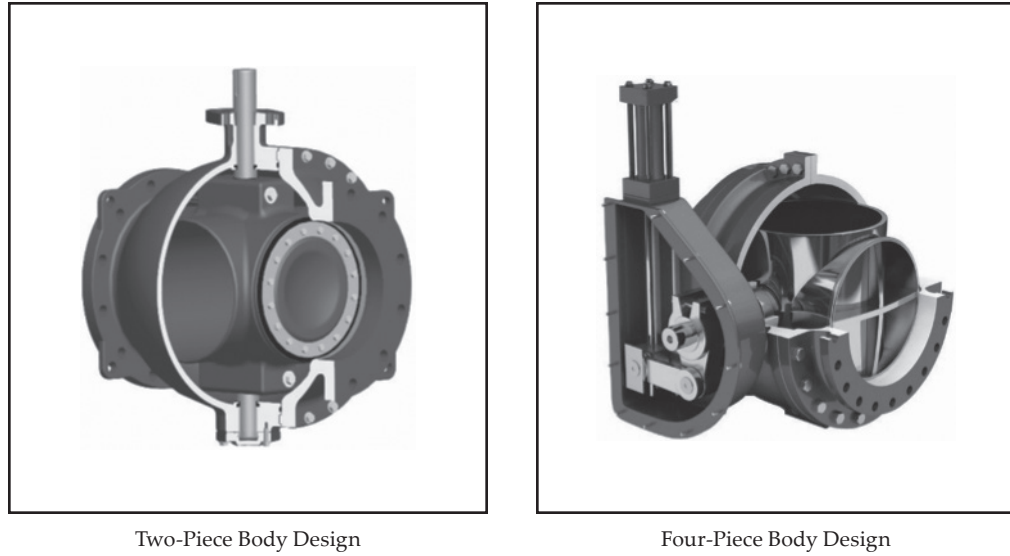

Courtesy of Val-Matic and DeZURIK

Figure 1-2 Typical ball valve construction

- The disc and seats may be symmetric (on center) design or single-offset, double-offset, or triple-offset designs.
- Symmetric and single-offset designs are position-seated and do not close tighter by increasing the seating shaft torque.
- Double- and triple-offset designs may be either position- or torque-seated. The seat seal will be tightened by increasing the shaft torque against the seat.
- They may be used in pump control service to control surges and may act as a power-operated check valve.
- They offer good flow control with a near equal percentage inherent valve characteristic.
- They offer very low full open head loss.
- Some designs may have a pressure seal direction preference.
- Some designs may have a flow and torque direction preference.

AWWA Plug Valve Design

AWWA PVs are characterized by the following design elements (see Figure 1-4):

- The PV primarily consists of an offset closure member (obturator/plug) that rotates about a quarter turn on a shaft within the valve body.
- Typically these valves have ports that are not circular and may have a full or slightly reduced port area.
- Seats are metallic-to-elastomeric.
- The plug and seat are an eccentric design (e.g., double-offset).
- Materials and construction are designed for both clean-water and wastewater service.
- PVs may be either position- or torque-seated, so the seat seal will be tightened by increasing the shaft torque against the seat.

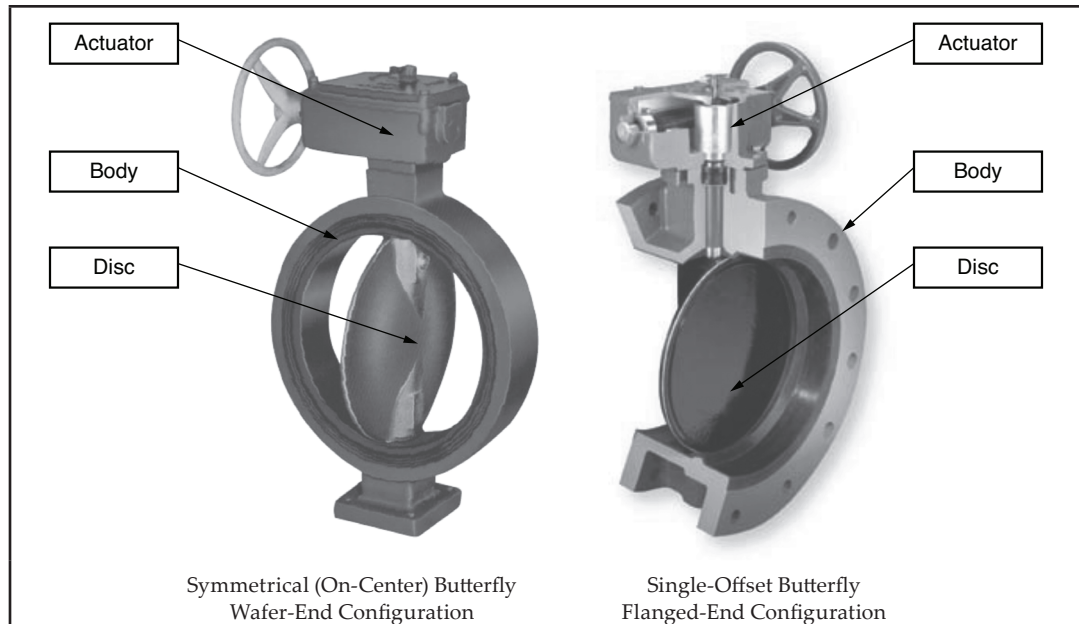

Courtesy of Pratt and DeZURIK

Figure 1-3 Typical butterfly valve construction

- They may be used in pump control service to control surges and may act as a power-operated check valve.
- In pump control service, a PV should be installed to seal tightest against system reverse flow, not pumped flow. (This generally places the seat end of the valve toward the pump.)
- They offer good flow control with a near equal percentage inherent valve characteristic.
- They offer moderate to low full open head loss.
- The normally preferred seal direction installation is the direct pressure orientation.

Rotary Cone Valve Design

Rotary cone valves used in the water and wastewater industry are not covered by an AWWA standard but are typically characterized by the following design elements (see Figure 1-5):

- They primarily consist of a bored and tapered conical closure member (obturator/cone) that rotates a quarter turn on a shaft or trunnion within the valve body and then seals by lowering the tapered cone into the metal seats with an axial movement.
- The actuator provides rotation and torque through the 90° operation and thrust or lift at the end of travel positions.
- Ports are full nominal size and unobstructed.
- Body is one piece with a closure bonnet or cover.
- Closure member (cone) is trunnion-mounted within the body.
- Closure member (cone) is typically symmetrically (concentrically) mounted and lift-seated but does close tighter by increasing the shaft thrust into the seat.
- Seat seals are metallic-to-metallic and generally Monel® for severe flow and corrosion-resistant service.