

ASME B89.3.4-2010

[Revision of ANSI/ASME B89.3.4M-1985 (R1992)]

Axes of Rotation: Methods for Specifying and Testing

AN AMERICAN NATIONAL STANDARD



The American Society of
Mechanical Engineers



INTENTIONALLY LEFT BLANK

ASME B89.3.4-2010

[Revision of ANSI/ASME B89.3.4M-1985 (R1992)]

Axes of Rotation: Methods for Specifying and Testing

AN AMERICAN NATIONAL STANDARD



**The American Society of
Mechanical Engineers**



Date of Issuance: May 12, 2010

This Standard will be revised when the Society approves the issuance of a new edition. There will be no addenda issued to this edition.

ASME issues written replies to inquiries concerning interpretations of technical aspects of this Standard. Periodically certain actions of the ASME B89 Committee may be published as Cases. Cases and interpretations are published on the ASME Web site under the Committee Pages at <http://cstools.asme.org> as they are issued.

ASME is the registered trademark of The American Society of Mechanical Engineers.

This code or standard was developed under procedures accredited as meeting the criteria for American National Standards. The Standards Committee that approved the code or standard was balanced to assure that individuals from competent and concerned interests have had an opportunity to participate. The proposed code or standard was made available for public review and comment that provides an opportunity for additional public input from industry, academia, regulatory agencies, and the public-at-large.

ASME does not “approve,” “rate,” or “endorse” any item, construction, proprietary device, or activity.

ASME does not take any position with respect to the validity of any patent rights asserted in connection with any items mentioned in this document, and does not undertake to insure anyone utilizing a standard against liability for infringement of any applicable letters patent, nor assume any such liability. Users of a code or standard are expressly advised that determination of the validity of any such patent rights, and the risk of infringement of such rights, is entirely their own responsibility.

Participation by federal agency representative(s) or person(s) affiliated with industry is not to be interpreted as government or industry endorsement of this code or standard.

ASME accepts responsibility for only those interpretations of this document issued in accordance with the established ASME procedures and policies, which precludes the issuance of interpretations by individuals.

No part of this document may be reproduced in any form,
in an electronic retrieval system or otherwise,
without the prior written permission of the publisher.

The American Society of Mechanical Engineers
Three Park Avenue, New York, NY 10016-5990

Copyright © 2010 by
THE AMERICAN SOCIETY OF MECHANICAL ENGINEERS
All rights reserved
Printed in U.S.A.

CONTENTS

Foreword	iv
Committee Roster	v
Correspondence With the B89 Committee	vi
1 Scope	7
2 Definitions	7
3 Specification or Description of Axis of Rotation	8
Figures	
1 Reference Coordinate Axes Directions, Axis of Rotation, and Error Motion of Spindle	1
2 Plan View of Spindle Showing General Case of Error Motion and Axial, Radial, Radial, and Tilt Motions	3
3 Polar Plots of Error Motion and Its Components	6
4 Error Motion Polar Plot Showing PC Center and LSC Center and Error Motion Values About These Centers	7
Table	
1 Error Motion Type and Preferred Center	7
Nonmandatory Appendices	
A Discussion of General Concepts	11
B Elimination of Master Ball Roundness Error	41
C Uncertainty Evaluation Procedure for Axes of Rotation	45
D References	59

FOREWORD

The testing of axes of rotation is at least as old as machine tools since most forms of machine tools incorporate such an axis. One of the more widely distributed European works on testing machine tools¹ devotes considerable attention to the problems encountered. Consideration of principles, equipment, and methods were included in the work.

Other European work² was carried forward and was published, in part, in 1959. As a result a variety of terms came into use throughout the world to describe and explain the various phenomena found during testing and subsequent use of machine tool spindles.

In the United States, work published in 1967³ represented a new viewpoint both in definitions and methods of testing. This work also underscored the lack of standardization of the entire subject of rotational axes. When the American National Standards Subcommittee B89.3, Geometry, was formed in February 1963, axes of rotation were not initially considered as a separate topic. This Standard, which was initiated by J. K. Emery in August 1968 as a part of the Geometry Subcommittee work, is the result of recognizing the need for uniform terminology and methods of testing for axes of rotation.

The goal in preparing the 1985 Standard was to produce a comprehensive document for the description, specification, and testing of axes of rotation. Extensive advisory material is provided in the Appendices as an aid to the user. It is recommended that this material be studied before putting the Standard to use. While the examples of the Appendices involve machine tools and measuring machines, the terminology and the underlying concepts are applicable to any situation in which the performance of a rotary axis is of concern.

The 1985 edition was adopted as an American National Standard by the American National Standards Institute (ANSI) on May 17, 1985.

The 1985 Standard laid the modern foundation for understanding, specifying, and testing axes of rotation. The cornerstones of this foundation are the following: the concept of error motion as opposed to runout; recognition of the role of the structural loop; differentiation between fixed and rotating sensitive direction; classification of radial, axial, tilt, and face error motions; separation of thermal drift from error motion, and dividing total error motion into average and asynchronous components. These concepts are illuminated by appendices with examples of test procedures and equipment, including a method of separating error motion from out-of-roundness of the test ball.

This revision more fully describes the periodic nature of error motions in order to point out the nonrandom, deterministic behavior of bearings. The term "average error motion" is now called "synchronous error motion." The distinction between synchronous and asynchronous is described in terms of frequency analysis. Distinction is also emphasized between axis error motions, axis shift (displacements due to changes in operating conditions), and structural motions.

The least squares circle is now preferred for determining the center when calculating most error motions. New definitions include stator, rotor, bearing, artifact, orientation angle, axis shift, spindle error motion, synchronous error motion, residual synchronous error motion, static error motion, stationary-point runout, setup hysteresis, frequency analysis, aliasing, and master axis. Manual evaluation of polar plots remains a valid method. A new appendix describes representative uncertainty evaluation procedures for error motion measurement.

ASME B89.3.4-2010 was approved by the American National Standards Institute on April 1, 2010.

¹ Schlesinger, G., *Testing Machine Tools*, Machinery Publishing Co.

² Tlustý, J., *System and Methods of Testing Machine Tools*, *Microtechnic*, 13, 162 (1959)

³ Bryan, J. B., Clouser, R. W., and Holland, E., *Spindle Accuracy*, *American Machinist*, Dec. 4, 1967

ASME B89 COMMITTEE

Dimensional Metrology

(The following is the roster of the Committee at the time of approval of this Standard.)

STANDARDS COMMITTEE OFFICERS

B. Parry, *Chair*
D. Beutel, *Vice Chair*
F. Constantino, *Secretary*

STANDARDS COMMITTEE PERSONNEL

D. Beutel , Caterpillar	R. J. Hocken , University of North Carolina
J. B. Bryan , Bryan and Associates	R. B. Hook , Metcon
T. Carpenter , U.S. Air Force Metrology Lab	M. P. Krystek , Physikalisch-Technische Bundesanstalt
R. L. Thompson , <i>Alternate</i> , U.S. Air Force Metrology Lab	M. Liebers , Professional Instruments Co.
T. Charlton, Jr. , Charlton Associates	E. Morse , University of North Carolina
D. J. Christy , Mahr Federal, Inc.	B. Parry , The Boeing Company
F. Constantino , The American Society of Mechanical Engineers	S. D. Phillips , National Institute of Standards and Technology
G. A. Hetland , International Institute of Geometric Dimensioning and Tolerancing	J. G. Salisbury , Mitutoyo America Corp.
	D. Sawyer , National Institute of Standards and Technology
	B. R. Taylor , Renishaw PLC

SUBCOMMITTEE 3 - GEOMETRY

M. Liebers , <i>Chair</i> , Professional Instruments Co.	J. D. Meadows , James D. Meadows & Associates, Inc.
J. B. Bryan , Bryan and Associates	T. Ralston , University of North Carolina

PROJECT TEAM 3.4 - AXES OF ROTATION

M. Liebers , <i>Chair</i> , Professional Instruments Co.	K. W. John , U.S. Air Force Metrology Lab
S. Badrawy , University of Michigan	B. R. Knapp , Professional Instruments Co.
J. B. Bryan , Bryan and Associates	S. S. Kumaran , Cummins Engine Co.
J. J. Costello , 3M Display & Graphics Business Lab	D. L. Martin , Lion Precision
J. A. Couey , Penn State University	R. J. McNaughton , The Timken Co.
T. M. Dalrymple , Dalrymple, Inc.	E. Morse , University of North Carolina — Charlotte
R. D. Grejda , Corning Tropol	T. P. Sheridan , Lorien Consultants Group

CORRESPONDENCE WITH THE B89 COMMITTEE

General. ASME Standards are developed and maintained with the intent to represent the consensus of concerned interests. As such, users of this Standard may interact with the Committee by requesting interpretations, proposing revisions, and attending Committee meetings. Correspondence should be addressed to:

Secretary, B89 Standards Committee
The American Society of Mechanical Engineers
Three Park Avenue
New York, NY 10016-5990
<http://go.asme.org/Inquiry>

Proposing Revisions. Revisions are made periodically to the Standard to incorporate changes that appear necessary or desirable, as demonstrated by the experience gained from the application of the Standard. Approved revisions will be published periodically.

The Committee welcomes proposals for revisions to this Standard. Such proposals should be as specific as possible, citing the paragraph number(s), the proposed wording, and a detailed description of the reasons for the proposal, including any pertinent documentation.

Proposing a Case. Cases may be issued for the purpose of providing alternative rules when justified, to permit early implementation of an approved revision when the need is urgent, or to provide rules not covered by existing provisions. Cases are effective immediately upon ASME approval and shall be posted on the ASME Committee Web page.

Requests for Cases shall provide a Statement of Need and Background Information. The request should identify the Code, the paragraph, figure, or table number(s), and be written as a Question and Reply in the same format as existing cases. Requests for Cases should also indicate the applicable edition(s) of the Code to which the proposed Case applies.

Interpretations. Upon request, the B89 Committee will render an interpretation of any requirement of the Standard. Interpretations can only be rendered in response to a written request sent to the Secretary of the B89 Standards Committee.

The request for interpretation should be clear and unambiguous. It is further recommended that the inquirer submit his/her request in the following format:

Subject: Cite the applicable paragraph number(s) and the topic of the inquiry.
Edition: Cite the applicable edition of the Standard for which the interpretation is being requested.
Question: Phrase the question as a request for an interpretation of a specific requirement suitable for general understanding and use, not as a request for an approval of a proprietary design or situation. The inquirer may also include any plans or drawings that are necessary to explain the question; however, they should not contain proprietary names or information.

Requests that are not in this format will be rewritten in this format by the Committee prior to being answered, which may inadvertently change the intent of the original request.

ASME procedures provide for reconsideration of any interpretation when or if additional information that might affect an interpretation is available. Further, persons aggrieved by an interpretation may appeal to the cognizant ASME Committee or Subcommittee. ASME does not "approve," "certify," "rate," or "endorse" any item, construction, proprietary device, or activity.

Attending Committee Meetings. The B89 Standards Committee regularly holds meetings, which are open to the public. Persons wishing to attend any meeting should contact the Secretary of the B89 Standards Committee.

AXES OF ROTATION: METHODS FOR SPECIFYING AND TESTING

1 SCOPE

This Standard is primarily intended for, but not limited to, the standardization of methods for specifying and testing axes of rotation of spindles used in machine tools and measuring machines. Appendices provide advisory information for the interpretation and use of this Standard.

1.1 Properties Included in This Standard

- (a) error motion
- (b) structural motion
- (c) compliance
- (d) axis shifts

1.2 Properties Not Included in This Standard

- (a) angular positioning accuracy
- (b) accelerometer, velocity, or microphone based measurements
- (c) dynamic compliance measurements
- (d) torque measurements
- (e) speed stability or load capacity

2 DEFINITIONS

2.1 General Concepts

The definitions in this Standard have been arranged to help the user develop an understanding of the terminology of axes of rotation.

2.1.1 Axis of Rotation

axis of rotation: a line segment about which rotation occurs.

NOTE: In general, this line segment translates and tilts with respect to the reference coordinate axes, as shown in Fig. 1.

2.1.2 Spindle

spindle: a device that provides an axis of rotation.

NOTE: Other named devices such as rotary tables, trunnions, and live centers are included within this definition.

2.1.3 Rotor

rotor: the rotating element of a spindle.

2.1.4 Stator

stator: the nonrotating element of a spindle.

2.1.5 Bearing

bearing: an element of a spindle that supports the rotor and allows rotation between the rotor and the stator.

Fig. 1 Reference Coordinate Axes Directions, Axis of Rotation, and Error Motion of Spindle

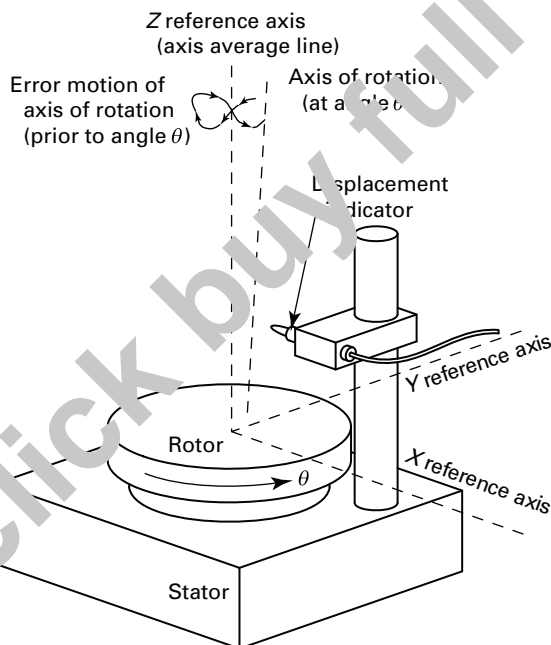

2.1.6 Reference Coordinate Axes

reference coordinate axes: mutually perpendicular X, Y, and Z axes, fixed with respect to a specified object.

NOTES:

- (1) For simplicity, the Z axis is chosen to lie along the axis average line, as in Fig. 1.
- (2) The specified object may be fixed or rotating.

2.1.7 Perfect Spindle

perfect spindle: a spindle having no motion of its axis of rotation relative to the reference coordinate axes.

2.1.8 Perfect Workpiece

perfect workpiece: a rigid body having a perfect surface of revolution about a centerline.

2.1.9 Axis Average Line

axis average line: a line segment passing through two axially separated radial error motion polar profile centers.

NOTES:

- (1) If the centers are not specified, the least squares circle (LSC) center is to be assumed.