

ASME B16.20-2017
(Revision of ASME B16.20-2012)

Metallic Gaskets for Pipe Flanges

AN AMERICAN NATIONAL STANDARD



**The American Society of
Mechanical Engineers**

ASME B16.20-2017
(Revision of ASME B16.20-2012)

Metallic Gaskets for Pipe Flanges

AN AMERICAN NATIONAL STANDARD



**The American Society of
Mechanical Engineers**

Two Park Avenue • New York, NY • 10016 USA

Date of Issuance: December 29, 2017

The next edition of this Standard is scheduled for publication in 2022.

ASME issues written replies to inquiries concerning interpretations of technical aspects of this Standard. Periodically certain actions of the ASME B16 Committee may be published as Cases. Cases and interpretations are published on the ASME Web site under the Committee Pages at <http://cstools.asme.org/> as they are issued.

Errata to codes and standards may be posted on the ASME Web site under the Committee Pages to provide corrections to incorrectly published items, or to correct typographical or grammatical errors in codes and standards. Such errata shall be based on the date posted.

The Committee Pages can be found at <http://cstools.asme.org/>. There is an option available to automatically receive an e-mail notification when errata are posted to a particular code or standard. This option can be found on the appropriate Committee Page after selecting "Errata" in the "Publication Information" section.

ASME is the registered trademark of The American Society of Mechanical Engineers.

This code or standard was developed under procedures agreed to as meeting the criteria for American National Standards. The Standards Committee that approved the code or standard was balanced to assure that individuals from competent and concerned interests have had an opportunity to participate. The proposed code or standard was made available for public review and comment that provides an opportunity for additional public input from industry, academia, regulatory agencies, and the public-at-large.

ASME does not "approve," "rate," or "endorse" an item, construction, proprietary device, or activity.

ASME does not take any position with respect to the validity of any patent rights asserted in connection with any items mentioned in this document, and does not undertake to insure anyone utilizing a standard against liability for infringement of any applicable letters patent, nor assume any such liability. Users of a code or standard are expressly advised that determination of the validity of any such patent rights, and the risk of infringement of such rights, are entirely their own responsibility.

Participation by federal agency representative(s) or person(s) affiliated with industry is not to be interpreted as government or industry endorsement of this code or standard.

ASME accepts responsibility for only those interpretations of this document issued in accordance with the established ASME procedures and policies, which precludes the issuance of interpretations by individuals.

No part of this document may be reproduced in any form,
in an electronic retrieval system or otherwise,
without the prior written permission of the publisher.

The American Society of Mechanical Engineers
Two Park Avenue, New York, NY 10016-5990

Copyright © 2017 by
THE AMERICAN SOCIETY OF MECHANICAL ENGINEERS
All rights reserved
Printed in U.S.A.

CONTENTS

Foreword		v
Committee Roster		vi
Correspondence With the B16 Committee		vii
Important Information Concerning Use of Asbestos or Alternative Materials		ix
Summary of Changes		x
List of Changes in Record Number Order		xi
PART GR	General Requirements	1
GR-1	Scope	1
GR-2	Quality Systems	1
GR-3	References	1
GR-4	Relevant Units	1
PART RJ	Ring-Joint Gaskets	2
RJ-1	Types	2
RJ-2	Size	2
RJ-3	Materials	2
RJ-4	Marking	2
RJ-5	Dimensions and Tolerances	2
RJ-6	Surface Finish	2
RJ-7	Identification Number	2
PART SW	Spiral-Wound Gaskets	15
SW-1	Size and Class	15
SW-2	Dimensions and Tolerances	15
SW-3	Materials	16
SW-4	Marking	16
PART JA	Jacketed Gaskets	33
JA-1	Size and Pressure Class	33
JA-2	Design	33
JA-3	Dimensions and Tolerances	33
JA-4	Materials	33
JA-5	Marking	33
PART GM	Grooved Metal Gaskets With Covering Layers	39
GM-1	Size and Class	39
GM-2	Dimensions and Tolerances	39
GM-3	Materials	39
GM-4	Marking	39
Mandatory Appendix		
I	References	48

Nonmandatory Appendix

A	Quality System Program	49
---	----------------------------------	----

Figures

SW-2.1-1	Spiral-Wound Gasket	17
JA-3-1	Jacketed Gasket	34
GM-2.1-1	Grooved Metal Gasket With Covering Layers	40
GM-4.1-1	Illustration of Example Markings for Grooved Metal Gaskets With Covering Layers	47

Tables

RJ-3.2-1	Maximum Hardness for Ring Gaskets	3
RJ-4-1	Ring Gasket Markings	3
RJ-5-1	Type R Ring Gasket Dimensions and Tolerances	4
RJ-5-2	Pipe Sizes for Type R Ring Gaskets Suitable for Referenced Standards	7
RJ-5-3	Type RX Ring Gasket Dimensions and Tolerances	10
RJ-5-4	Pipe Sizes for Type RX Ring Gaskets Suitable for Referenced Standards	12
RJ-5-5	Type BX Ring Gasket Dimensions and Tolerances	13
RJ-5-6	Pipe Sizes for Type BX Ring Gaskets Suitable for Referenced Standards	14
SW-2.1-1	Dimensions for Spiral-Wound Gaskets Used With ASME B16.5 Flanges	18
SW-2.1-2	Dimensions for Spiral-Wound Gaskets Used With ASME B16.47 Series A Flanges	20
SW-2.1-3	Dimensions for Spiral-Wound Gaskets Used With ASME B16.47 Series B Flanges	22
SW-2.1-4	Inside Diameters of Inner Rings for Spiral-Wound Gaskets for Use With ASME B16.5 Flanges	24
SW-2.1-5	Inside Diameters of Inner Rings for Spiral-Wound Gaskets Used Between ASME B16.47 Series A Flanges	25
SW-2.1-6	Inside Diameters of Inner Rings for Spiral-Wound Gaskets Used Between ASME B16.47 Series B Flanges	26
SW-2.5-1	Minimum Pipe Wall Thickness Suitable for Use of Spiral-Wound Gaskets With Inner Rings for ASME B16.5 Flanges	27
SW-2.5-2	Maximum Bore of ASME B16.5 Flanges for Use With Spiral-Wound Gaskets	28
SW-2.5-3	Maximum Bore of ASME B16.47 Series A Flanges for Use With Spiral-Wound Gaskets	29
SW-2.5-4	Maximum Bore of ASME B16.47 Series B Flanges for Use With Spiral-Wound Gaskets	30
SW-3-1	Color Coding and Abbreviations for Spiral-Wound Gasket Materials	31
SW-4.1-1	Example Markings for Spiral-Wound Gaskets	32
JA-3-1	Jacketed Gasket Dimensions for ASME B16.5 Flanges	35
JA-3-2	Jacketed Gasket Dimensions for ASME B16.47 Series A Flanges	36
JA-3-3	Jacketed Gasket Dimensions for ASME B16.47 Series B Flanges	37
JA-4-1	Abbreviations for Identifying Materials for Jacketed Gaskets	38
JA-5.1-1	Example Markings for Jacketed Gaskets	38
GM-2.1-1	Dimensions for Grooved Metal Gaskets With Covering Layers Used With ASME B16.5 Flanges	41
GM-2.1-2	Dimensions for Grooved Metal Gaskets With Covering Layers Used With ASME B16.47 Series A Flanges	42
GM-2.1-3	Dimensions for Grooved Metal Gaskets With Covering Layers Used With ASME B16.47 Series B Flanges	44
GM-3.1-1	Color Coding and Abbreviations for Grooved Metal Gaskets With Covering Layers Materials	46
GM-4.1-1	Example Markings for Grooved Metal Gaskets With Covering Layers	47

FOREWORD

Ring-joint gaskets and grooves probably originated in the boiler field, where they were used in various forms for manhole covers, autoclaves, and other closures; however, it was in the oil industry (both in the production and refining of oil) that they received the greatest recognition and were developed into their present form. Their use expanded steadily as temperatures and pressures were increased in steam plants. Tests examining their application in flanges and valves were conducted as early as 1928.

In June 1936, the American Petroleum Institute (API) issued Tentative Standard 5-G-3 on Ring-Joints for Steel Flanges and Flange Unions for use with API Tubular Goods. This standard was known as API Specification 6B, Ring-Joint Flanges. Following the acceptance of ring-joints for flanges and valves by API and the issuance of their standard, ASA B16 on Steel Pipe Flanges and Flanged Fittings was revised to include them, and the 1939 edition included standard dimensions for a full line of ring-joint flanges based on the API standard. Development work continued, and API formulated Standard 6E, Specification for Wellhead Equipment, which included ring-joints not covered in ASA B16-1939.

In 1949, the American Standards Association (ASA), Sectional Committee B16, Subcommittee 3, Steel Flanges and Flanged Fittings, assembled the available information on ring-joint gaskets into a single standard. ASA approved the Standard, with the designation ASA B16.20-1952, on April 30, 1952.

On April 4, 1955, ASA approved an updated edition with the designation ASA B16.20-1955. Ring gaskets for Class 900 (900 lb at that time) in sizes NPS 26 through NPS 36 were added in the next edition, which ASA approved on April 2, 1956. The Standard was again reviewed in 1962, and ASA approved it on April 25, 1962. In 1973, the Standard was revised, and the American National Standards Institute (ANSI) approved it as an American National Standard.

Following publication of the 1973 edition, API requested that ASME convert their gasket standard, API 601, into an ASME American National Standard. As a result of that request, the Standard was expanded to include requirements for spiral-wound and jacketed gaskets that were formerly listed in API 601, 7th edition, 1988. Ring-joint groove dimensions were not included, because they were included in ASME/ANSI B16.5-1988, Pipe Flanges and Flanged Fittings, and ASME B16.47-1990, Large Diameter Steel Flanges. The revised Standard was approved by ANSI on January 22, 1993.

Subsequent editions further expanded the Standard. In the 1998 edition, a quality system program annex was added. In the 2007 edition, metric dimensions were adopted as an independent standard to the U.S. Customary units, and Mandatory Appendix I was added to cover dimensional tables in U.S. Customary units. In the 2012 edition, a new chapter for grooved metal gaskets with covering layers was added.

In this 2017 edition, the entire Standard has been reorganized based on the different types of gaskets. In addition, the title of the Standard has been revised, as have multiple paragraphs, tables, and figures. Following approval by the ASME B16 Standards Committee, ANSI approved ASME B16.20-2017 as an American National Standard on October 11, 2017.

ASME B16 COMMITTEE

Standardization of Valves, Flanges, Fittings, and Gaskets

(The following is the roster of the Committee at the time of approval of this Standard.)

STANDARDS COMMITTEE OFFICERS

R. M. Bojarczuk, *Chair*
C. E. Davila, *Vice Chair*
C. R. Ramcharran, *Secretary*

STANDARDS COMMITTEE PERSONNEL

A. Appleton, Alloy Stainless Products Co., Inc.
J. E. Barker, Dezurik Water Controls
K. Barron, Ward Manufacturing
D. C. Bayreuther, Metso Automation, Flow Control Division
W. B. Bedesem, Consultant
R. M. Bojarczuk, ExxonMobil Research & Engineering Co.
A. M. Cheta, Qatar Shell GTL
M. A. Clark, NIBCO, Inc.
G. A. Cuccio, Capitol Manufacturing Co.
J. D'Avanzo, Fluoroseal Valves
C. E. Davila, Crane Energy
K. S. Felder, Valero Energy
D. R. Frikken, Becht Engineering Co.
R. B. Hai, RBH Associates
D. Hunt, Jr., Fastenal Co.
G. A. Jolly, Samshin, Ltd.
E. J. Lain, Exelon Nuclear
T. A. McMahon, Emerson Process Management
R. C. Merrick, Fluor Enterprises
M. L. Nayyar, NICE
W. H. Patrick, Dow Chemical Co.
D. Rahoji, CCM 2000
C. R. Ramcharran, The American Society of Mechanical Engineers
D. F. Reid, VSP Technologies
R. A. Schmidt, Cambridge
J. Tucker, Flowsolve
F. R. Volstadt, Volstadt & Associates, Inc.
F. Feng, *Delegated* China Productivity Center for Machinery, National Technical Committee
R. Barnes, *Contributing Member*, Anric Enterprises, Inc.
P. V. Craig, *Contributing Member*, Jomar Group
B. G. Fabian, *Contributing Member*, Pennsylvania Machine Works
M. Kacner, *Contributing Member*, Haynes International
A. G. Kireta, Jr., *Contributing Member*, Copper Development Association, Inc.

SUBCOMMITTEE – GASKETS FOR FLANGED JOINTS

D. F. Reid, *Chair*, VSP Technologies
E. J. Lain, *Vice Chair*, Exelon Nuclear
C. Ramcharran, *Secretary*, The American Society of Mechanical Engineers
J. Baulch, Teadit North America
R. M. Bojarczuk, ExxonMobil Research & Engineering Co.
K. S. Felder, Valero Energy
P. R. Francis, Thermoseal, Inc.
D. R. Frikken, Becht Engineering Co.
K. E. Guenther, Shell
E. Jamalyaria, Flexitallic Engineering
Y. Li, Flexitallic L.P.
L. Melvin, Leader Global Technologies, Inc.
R. T. Mueller, Consultant
D. Reeves, Sealing and Bolting Technologies, LLC
M. Ruffin, Chevron
C. Yoder, Garlock Sealing Technologies
H. Azibert, *Contributing Member*, Camtrack, LLC
D. H. Monroe, *Contributing Member*, Consultant

CORRESPONDENCE WITH THE B16 COMMITTEE

General. ASME Standards are developed and maintained with the intent to represent the consensus of concerned interests. As such, users of this Standard may interact with the Committee by requesting interpretations, proposing revisions or a case, and attending Committee meetings. Correspondence should be addressed to:

Secretary, B16 Standards Committee
The American Society of Mechanical Engineers
Two Park Avenue
New York, NY 10016-5990
<http://go.asme.org/Inquiry>

Proposing Revisions. Revisions are made periodically to the Standard to incorporate changes that appear necessary or desirable, as demonstrated by the experience gained from the application of the Standard. Approved revisions will be published periodically.

The Committee welcomes proposals for revisions to this Standard. Such proposals should be as specific as possible, citing the paragraph number(s), the proposed wording, and a detailed description of the reasons for the proposal, including any pertinent documentation.

Proposing a Case. Cases may be issued to provide alternative rules when justified, to permit early implementation of an approved revision when the need is urgent, or to provide rules not covered by existing provisions. Cases are effective immediately upon ASME approval and shall be posted on the ASME Committee Web page.

Requests for Cases shall provide a Statement of Need and Background Information. The request should identify the Standard and the paragraph, figure, or table number(s), and be written as a Question and Reply in the same format as existing Cases. Requests for Cases should also indicate the applicable edition(s) of the Standard to which the proposed Case applies.

Interpretations. Upon request, the B16 Standards Committee will render an interpretation of any requirement of the Standard. Interpretations can only be rendered in response to a written request sent to the Secretary of the B16 Standards Committee.

Requests for interpretation should preferably be submitted through the online Interpretation Submittal Form. The form is accessible at <http://go.asme.org/interpretationRequest>. Upon submittal of the form, the Inquirer will receive an automatic e-mail confirming receipt.

If the Inquirer is unable to use the online form, he/she may e-mail the request to the Secretary of the B16 Standards Committee at SecretaryB16@asme.org, or mail it to the above address. The request for an interpretation should be clear and unambiguous. It is further recommended that the Inquirer submit his/her request in the following format:

Subject: Cite the applicable paragraph number(s) and the topic of the inquiry in one or two words.
Edition: Cite the applicable edition of the Standard for which the interpretation is being requested.
Question: Phrase the question as a request for an interpretation of a specific requirement suitable for general understanding and use, not as a request for an approval of a proprietary design or situation. Please provide a condensed and precise question, composed in such a way that a “yes” or “no” reply is acceptable.
Proposed Reply(ies): Provide a proposed reply(ies) in the form of “Yes” or “No,” with explanation as needed. If entering replies to more than one question, please number the questions and replies.
Background Information: Provide the Committee with any background information that will assist the Committee in understanding the inquiry. The Inquirer may also include any plans or drawings that are necessary to explain the question; however, they should not contain proprietary names or information.

Requests that are not in the format described above may be rewritten in the appropriate format by the Committee prior to being answered, which may inadvertently change the intent of the original request.

Moreover, ASME does not act as a consultant for specific engineering problems or for the general application or understanding of the Standard requirements. If, based on the inquiry information submitted, it is the opinion of the Committee that the Inquirer should seek assistance, the inquiry will be returned with the recommendation that such assistance be obtained.

ASME procedures provide for reconsideration of any interpretation when or if additional information that might affect an interpretation is available. Further, persons aggrieved by an interpretation may appeal to the cognizant ASME Committee or Subcommittee. ASME does not “approve,” “certify,” “rate,” or “endorse” any item, construction, proprietary device, or activity.

Attending Committee Meetings. The B16 Standards Committee regularly holds meetings and/or telephone conferences that are open to the public. Persons wishing to attend any meeting and/or telephone conference should contact the Secretary of the B16 Standards Committee.

IMPORTANT INFORMATION CONCERNING USE OF ASBESTOS OR ALTERNATIVE MATERIALS

Asbestos is referenced for use as a filler material in metallic gaskets. It has served as a universal sealing material compatible with most fluid services. It has been of extreme usefulness in minimizing fire hazards.

Certain serious adverse health effects are associated with asbestos, among them the serious and often fatal diseases of lung cancer, asbestosis, and mesothelioma (a cancer of the chest and abdominal linings). The degree of exposure to asbestos varies with the product and the work practices involved.

Consult the most recent edition of the Occupational Safety and Health Administration, U.S. Department of Labor, Occupational Safety and Health Standard for Asbestos, Tremolite, Anthophyllite, and Actinolite, 29 Code of Federal Regulations Section 1910.1001; the U.S. Environmental Protection Agency National Emission Standard for Asbestos, 40 Code of Federal Regulations Sections 61.140 through 61.156; and the U.S. Environmental Protection Agency rule requiring the labeling and phased banning of asbestos products, published in 51 Federal Register 3738-3759 (January 29, 1986).

There are currently in use and under development a number of substitute materials to replace asbestos in certain applications. Manufacturers and users are encouraged to develop and use effective substitute materials that can meet the specifications for, and operating requirements of, the equipment to which they would apply.

Information concerning safety and health risks and proper precautions with respect to particular materials and conditions should be obtained from one's employer, the manufacturer or supplier of that material, or the Material Safety Data Sheet.

ASME B16.20-2017

SUMMARY OF CHANGES

Following approval by the B16 Committee and ASME, and after public review, ASME B16.20-2017 was approved by the American National Standards Institute on October 11, 2017.

ASME B16.20-2017 has been revised in its entirety. The Standard title has been revised (13-901); the paragraphs, figures, and tables have been restructured and redesignated (14-756); and cross-references have been updated accordingly. In addition, this edition includes the following changes identified by a margin note, (17). The Record Numbers cited above and listed below are explained in more detail in “List of Changes in Record Number Order” following this Summary of Changes.

<i>Page</i>	<i>Location</i>	<i>Change (Record Number)</i>
15	SW-2.2	Formerly para. 3.2.2; revised (16-2540)
16	SW-2.6	Formerly para. 3.2.6; revised (12-519, 16-2540)
17	Figure SW-2.1-1	Formerly Figures 1 and I-1; revised (14-750)
18	Table SW-2.1-1	Formerly Tables 9 and I-4; values for NPS 3½ added and Notes revised (16-2147)
20	Table SW-2.1-2	Formerly Tables 10 and I-5; General Notes and Note (2) revised (13-914)
22	Table SW-2.1-3	Formerly Tables 11 and I-6; under “U.S. Customary, in.,” Inside Diameter of Gasket for NPS 38 and NPS 58, and Outside Diameter of Gasket for NPS 56 revised; and Note (2) revised (13-914)
24	Table SW-2.1-4	Formerly Tables 12 and I-7; values for NPS 3½ added and Note (1) revised (16-2147)
40	Figure GM-2.1-1	Formerly Figure 3; revised (14-758)

LIST OF CHANGES IN RECORD NUMBER ORDER

<u>Record Number</u>	<u>Change</u>
12-519	Deleted para. 3.2.6.
13-901	Revised title of the Standard.
13-914	Editorially revised Tables I-5 and I-6.
14-750	In Figures 1 and I-1, provided guidance into the measurement of the outside diameter of gaskets.
14-756	Reorganized ASME B16.20 based on the different gasket types.
14-758	Clarified groove details in Figure 3.
16-2147	Added data for NPS 3½ flange to Tables 9, 12, I-4, and I-7.
16-2540	Revised existing para. 3.2.2 and added para. 3.2.6 to replace the now-deleted para. 3.2.6. The revised construction and compression criteria will permit filler to extend above the metal winding and have adequate compressive strength to resist expected bolt loads for a given flange Class, and reflects current bolting practices per ASME PCC-1 where bolt stress is based on gasket stress.

INTENTIONALLY LEFT BLANK

PART GR

GENERAL REQUIREMENTS

GR-1 SCOPE

This Standard covers materials, dimensions, tolerances, and markings for metal ring-joint gaskets, spiral-wound metal gaskets, metal-jacketed gaskets, and grooved metal gaskets with covering layers. These gaskets are dimensionally suitable for use with flanges described in reference flange standards ASME B16.5, ASME B16.47, API Specification 6A, and ISO 10423.

GR-2 QUALITY SYSTEMS

Requirements relating to the product manufacturers' quality system programs are described in [Nonmandatory Appendix A](#).

GR-3 REFERENCES

Standards and specifications adopted by reference in this Standard are shown in [Mandatory Appendix I](#).

GR-4 RELEVANT UNITS

This Standard states values in both SI (Metric) and U.S. Customary units. These systems of units are to be regarded separately as standard. Within the text, the U.S. Customary units are shown in parentheses. The values stated in each system are not exact equivalents; therefore, it is required that each system of units be used independently of the other. Combining values from the two systems constitutes nonconformance with the Standard.

PART RJ

RING-JOINT GASKETS

RJ-1 TYPES

Ring-joint gaskets shall be either octagonal or oval in cross section.

RJ-2 SIZE

Ring-joint gaskets shall be identified by an R, RX, or BX number that relates to flange size (NPS), pressure class, and the appropriate flange standards (ASME B16.5, ASME B16.47, API Specification 6A, or ISO 10423).

RJ-3 MATERIALS

RJ-3.1 General

Ring-joint gasket materials, some of which are listed in [Table RJ-3.2-1](#), shall be selected by the user based on suitability for the service conditions.

It is recommended that ring-joint gaskets be of a lesser hardness than that of the mating flanges.

RJ-3.2 Hardness

Ring-joint gaskets of materials listed in [Table RJ-3.2-1](#) shall have a hardness equal to or less than that shown in [Table RJ-3.2-1](#).

RJ-4 MARKING

The outer surface of each gasket shall carry the manufacturer's name or identification trademark and gasket number prefixed by the letters R, RX, or BX, followed by the gasket material identification. Materials shall be identified as shown in [Table RJ-4-1](#). The gasket shall also be marked with an ASME B16.20 designation. The marking shall be applied so as not to harmfully distort the gasket or affect the integrity of the seal.

RJ-5 DIMENSIONS AND TOLERANCES

Dimensions and tolerances for ring-joint gaskets shall be as shown in [Tables RJ-5-1](#) through [RJ-5-6](#).

RJ-6 SURFACE FINISH

Types R and RX gaskets shall have a surface finish not rougher than 1.6 μm (63 $\mu\text{in.}$) roughness. Type BX gaskets shall have a surface finish not rougher than 0.8 μm (32 $\mu\text{in.}$) roughness. Surface finish shall pertain to the gasket-sealing surface.

RJ-7 IDENTIFICATION NUMBER

Dimensional reference identification numbers are assigned to ring-joint gaskets and shown in [Tables RJ-5-1](#) through [RJ-5-6](#).

Table RJ-3.2-1 Maximum Hardness for Ring Gaskets

Ring Gasket Material	Maximum Hardness	
	Brinell	Rockwell "B" Scale
Soft iron [Note (1)]	90	56
Low-carbon steel	120	68
4-6 chrome 1/2Mo	130	72
Type 410	170	86
Type 304	160	83
Type 316	160	83
Type 347	160	83

NOTE: (1) May be low-carbon steel, not to exceed maximum hardness of 90 Brinell — 56 Rockwell "B."

Table RJ-4-1 Ring Gasket Markings

Ring Gasket Material	Identification	Marking Example [Note (1)]
Soft iron [Note (2)]	D	R51D
Low-carbon steel	S	R51S
4-6 chrome 1/2Mo	F5 [Note (3)]	R51F5
Type 410	S 410	R51S410
Type 304	S 304	R51S304
Type 316	S 316	R51S316
Type 347	S 347	R51S347

NOTES:

- (1) This number shall be preceded by the manufacturer's name or identification trademark.
- (2) May be low-carbon steel, not to exceed maximum hardness of 90 Brinell — 56 Rockwell "B."
- (3) F5 identification designates ASTM specification A182-72 chemical composition requirements only.

Table RJ-5-1 Type R Ring Gasket Dimensions and Tolerances

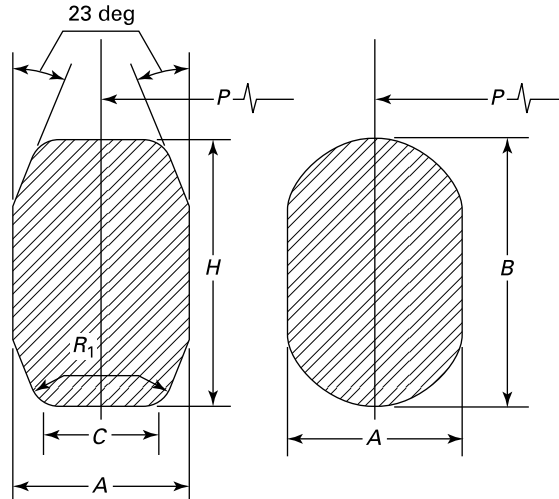

Ring Number	Average Pitch Diameter of Ring, P, mm (in.)	Width of Ring, A, mm (in.)	Height of Ring, mm (in.)		Width of Flat on Octagonal Ring, C, mm (in.)	Radius in Octagonal Ring, R ₁ , mm (in.)
			Oval, B	Octagonal, H		
R-11	34.14 (1.344)	6.35 (0.250)	11.2 (0.44)	9.7 (0.38)	4.32 (0.170)	1.5 (0.06)
R-12	39.70 (1.563)	7.95 (0.313)	14.2 (0.56)	12.7 (0.50)	5.23 (0.206)	1.5 (0.06)
R-13	42.88 (1.688)	7.95 (0.313)	14.2 (0.56)	12.7 (0.50)	5.23 (0.206)	1.5 (0.06)
R-14	44.45 (1.750)	7.95 (0.313)	14.2 (0.56)	12.7 (0.50)	5.23 (0.206)	1.5 (0.06)
R-15	47.63 (1.875)	7.95 (0.313)	14.2 (0.56)	12.7 (0.50)	5.23 (0.206)	1.5 (0.06)
R-16	50.80 (2.000)	7.95 (0.313)	14.2 (0.56)	12.7 (0.50)	5.23 (0.206)	1.5 (0.06)
R-17	57.15 (2.250)	7.95 (0.313)	14.2 (0.56)	12.7 (0.50)	5.23 (0.206)	1.5 (0.06)
R-18	60.33 (2.375)	7.95 (0.313)	14.2 (0.56)	12.7 (0.50)	5.23 (0.206)	1.5 (0.06)
R-19	65.10 (2.563)	7.95 (0.313)	14.2 (0.56)	12.7 (0.50)	5.23 (0.206)	1.5 (0.06)
R-20	68.28 (2.688)	7.95 (0.313)	14.2 (0.56)	12.7 (0.50)	5.23 (0.206)	1.5 (0.06)
R-21	72.24 (2.844)	11.13 (0.438)	17.5 (0.69)	16.0 (0.63)	7.75 (0.305)	1.5 (0.06)
R-22	82.55 (3.250)	7.95 (0.313)	14.2 (0.56)	12.7 (0.50)	5.23 (0.206)	1.5 (0.06)
R-23	82.55 (3.250)	11.13 (0.438)	17.5 (0.69)	16.0 (0.63)	7.75 (0.305)	1.5 (0.06)
R-24	95.25 (3.750)	11.13 (0.438)	17.5 (0.69)	16.0 (0.63)	7.75 (0.305)	1.5 (0.06)
R-25	101.60 (4.000)	7.95 (0.313)	14.2 (0.56)	12.7 (0.50)	5.23 (0.206)	1.5 (0.06)
R-26	101.60 (4.000)	11.13 (0.438)	17.5 (0.69)	16.0 (0.63)	7.75 (0.305)	1.5 (0.06)
R-27	107.95 (4.250)	11.13 (0.438)	17.5 (0.69)	16.0 (0.63)	7.75 (0.305)	1.5 (0.06)
R-28	111.13 (4.375)	12.70 (0.500)	19.1 (0.75)	17.5 (0.69)	8.66 (0.341)	1.5 (0.06)
R-29	114.30 (4.500)	7.95 (0.313)	14.2 (0.56)	12.7 (0.50)	5.23 (0.206)	1.5 (0.06)
R-30	117.48 (4.625)	11.13 (0.438)	17.5 (0.69)	16.0 (0.63)	7.75 (0.305)	1.5 (0.06)
R-31	123.83 (4.875)	11.13 (0.438)	17.5 (0.69)	16.0 (0.63)	7.75 (0.305)	1.5 (0.06)
R-32	127.00 (5.000)	12.70 (0.500)	19.1 (0.75)	17.5 (0.69)	8.66 (0.341)	1.5 (0.06)
R-33	131.78 (5.188)	7.95 (0.313)	14.2 (0.56)	12.7 (0.50)	5.23 (0.206)	1.5 (0.06)
R-34	131.78 (5.188)	11.13 (0.438)	17.5 (0.69)	16.0 (0.63)	7.75 (0.305)	1.5 (0.06)
R-35	136.53 (5.375)	11.13 (0.438)	17.5 (0.69)	16.0 (0.63)	7.75 (0.305)	1.5 (0.06)
R-36	149.23 (5.875)	7.95 (0.313)	14.2 (0.56)	12.7 (0.50)	5.23 (0.206)	1.5 (0.06)
R-37	149.23 (5.875)	11.13 (0.438)	17.5 (0.69)	16.0 (0.63)	7.75 (0.305)	1.5 (0.06)
R-38	157.18 (6.188)	15.88 (0.625)	22.4 (0.88)	20.6 (0.81)	10.49 (0.413)	1.5 (0.06)
R-39	161.93 (6.375)	11.13 (0.438)	17.5 (0.69)	16.0 (0.63)	7.75 (0.305)	1.5 (0.06)

Table RJ-5-1 Type R Ring Gasket Dimensions and Tolerances (Cont'd)

Ring Number	Average Pitch Diameter of Ring, <i>P</i> , mm (in.)	Width of Ring, <i>A</i> , mm (in.)	Height of Ring, mm (in.)		Width of Flat on Octagonal Ring, <i>C</i> , mm (in.)	Radius in Octagonal Ring, <i>R</i> ₁ , mm (in.)
			Oval, <i>B</i>	Octagonal, <i>H</i>		
R-40	171.45 (6.750)	7.95 (0.313)	14.2 (0.56)	12.7 (0.50)	5.23 (0.206)	1.5 (0.06)
R-41	180.98 (7.125)	11.13 (0.438)	17.5 (0.69)	16.0 (0.63)	7.75 (0.305)	1.5 (0.06)
R-42	190.50 (7.500)	19.05 (0.750)	25.4 (1.00)	23.9 (0.94)	12.32 (0.485)	1.5 (0.06)
R-43	193.68 (7.625)	7.95 (0.313)	14.2 (0.56)	12.7 (0.50)	5.23 (0.206)	1.5 (0.06)
R-44	193.68 (7.625)	11.13 (0.438)	17.5 (0.69)	16.0 (0.63)	7.75 (0.305)	1.5 (0.06)
R-45	211.15 (8.313)	11.13 (0.438)	17.5 (0.69)	16.0 (0.63)	7.75 (0.305)	1.5 (0.06)
R-46	211.15 (8.313)	12.70 (0.500)	19.1 (0.75)	17.5 (0.69)	8.66 (0.341)	1.5 (0.06)
R-47	228.60 (9.000)	19.05 (0.750)	25.4 (1.00)	23.9 (0.94)	12.32 (0.485)	1.5 (0.06)
R-48	247.65 (9.750)	7.95 (0.313)	14.2 (0.56)	12.7 (0.50)	5.23 (0.206)	1.5 (0.06)
R-49	269.88 (10.625)	11.13 (0.438)	17.5 (0.69)	16.0 (0.63)	7.75 (0.305)	1.5 (0.06)
R-50	269.88 (10.625)	15.88 (0.625)	22.4 (0.88)	20.6 (0.81)	10.49 (0.413)	1.5 (0.06)
R-51	279.40 (11.000)	22.23 (0.875)	28.7 (1.13)	26.9 (1.06)	14.81 (0.583)	1.5 (0.06)
R-52	304.80 (12.000)	7.95 (0.313)	14.2 (0.56)	12.7 (0.50)	5.23 (0.206)	1.5 (0.06)
R-53	323.85 (12.750)	11.13 (0.438)	17.5 (0.69)	16.0 (0.63)	7.75 (0.305)	1.5 (0.06)
R-54	323.85 (12.750)	15.88 (0.625)	22.4 (0.88)	20.6 (0.81)	10.49 (0.413)	1.5 (0.06)
R-55	342.90 (13.500)	28.58 (1.125)	36.6 (1.44)	35.1 (1.38)	19.81 (0.780)	2.3 (0.09)
R-56	381.00 (15.000)	7.95 (0.313)	14.2 (0.56)	12.7 (0.50)	5.23 (0.206)	1.5 (0.06)
R-57	381.00 (15.000)	11.13 (0.438)	17.5 (0.69)	16.0 (0.63)	7.75 (0.305)	1.5 (0.06)
R-58	381.00 (15.000)	22.23 (0.875)	28.7 (1.13)	26.9 (1.06)	14.81 (0.583)	1.5 (0.06)
R-59	396.88 (15.625)	7.95 (0.313)	14.2 (0.56)	12.7 (0.50)	5.23 (0.206)	1.5 (0.06)
R-60	406.40 (16.000)	31.75 (1.250)	39.6 (1.56)	38.1 (1.50)	22.33 (0.879)	2.3 (0.09)
R-61	419.10 (16.500)	11.13 (0.438)	17.5 (0.69)	16.0 (0.63)	7.75 (0.305)	1.5 (0.06)
R-62	419.10 (16.500)	15.88 (0.625)	22.4 (0.88)	20.6 (0.81)	10.49 (0.413)	1.5 (0.06)
R-63	419.10 (16.500)	25.40 (1.000)	33.3 (1.31)	31.8 (1.25)	17.30 (0.681)	2.3 (0.09)
R-64	454.03 (17.875)	7.95 (0.313)	14.2 (0.56)	12.7 (0.50)	5.23 (0.206)	1.5 (0.06)
R-65	469.90 (18.500)	11.13 (0.438)	17.5 (0.69)	16.0 (0.63)	7.75 (0.305)	1.5 (0.06)
R-66	469.90 (18.500)	15.88 (0.625)	22.4 (0.88)	20.6 (0.81)	10.49 (0.413)	1.5 (0.06)
R-67	469.90 (18.500)	28.58 (1.125)	36.6 (1.44)	35.1 (1.38)	19.81 (0.780)	2.3 (0.09)
R-68	517.53 (20.375)	7.95 (0.313)	14.2 (0.56)	12.7 (0.50)	5.23 (0.206)	1.5 (0.06)
R-69	533.40 (21.000)	11.13 (0.438)	17.5 (0.69)	16.0 (0.63)	7.75 (0.305)	1.5 (0.06)
R-70	533.40 (21.000)	19.05 (0.750)	25.4 (1.00)	23.9 (0.94)	12.32 (0.485)	1.5 (0.06)
R-71	533.40 (21.000)	28.58 (1.125)	36.6 (1.44)	35.1 (1.38)	19.81 (0.780)	2.3 (0.09)
R-72	558.80 (22.000)	7.95 (0.313)	14.2 (0.56)	12.7 (0.50)	5.23 (0.206)	1.5 (0.06)
R-73	584.20 (23.000)	12.70 (0.500)	19.1 (0.75)	17.5 (0.69)	8.66 (0.341)	1.5 (0.06)
R-74	584.20 (23.000)	19.05 (0.750)	25.4 (1.00)	23.9 (0.94)	12.32 (0.485)	1.5 (0.06)
R-75	584.20 (23.000)	31.75 (1.250)	39.6 (1.56)	38.1 (1.50)	22.33 (0.879)	2.3 (0.09)
R-76	673.10 (26.500)	7.95 (0.313)	14.2 (0.56)	12.7 (0.50)	5.23 (0.206)	1.5 (0.06)
R-77	692.15 (27.250)	15.88 (0.625)	22.4 (0.88)	20.6 (0.81)	10.49 (0.413)	1.5 (0.06)
R-78	692.15 (27.250)	25.40 (1.000)	33.3 (1.31)	31.8 (1.25)	17.30 (0.681)	2.3 (0.09)
R-79	692.15 (27.250)	34.93 (1.375)	44.5 (1.75)	41.4 (1.63)	24.82 (0.977)	2.3 (0.09)
R-80	615.95 (24.250)	7.95 (0.313)	...	12.7 (0.50)	5.23 (0.206)	1.5 (0.06)