



Click buy full version

Wind Loads

Guide to the Wind Load Provisions of ASCE 7-05

Kishor C. Mehta, Ph.D., P.E.
William L. Coulbourne, P.E.

ASCE
PRESS

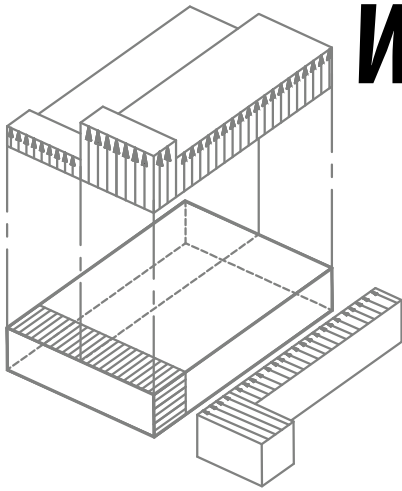

Wind Loads

Currently in preview, click buy full version

Other Titles of Interest

Minimum Design Loads for Buildings and Other Structures, ASCE/SEI 7-05.

(ASCE Standard, 2006). Provides requirements for general structural design and includes means for determining various loads and their combinations. Includes commentary. (ISBN 978-0-7844-0831-5)

Snow Loads: Guide to the Snow Load Provisions of ASCE 7-05, by Michael

O'Rourke. (ASCE Press, 2007). Presents a detailed, authoritative interpretation of the snow load provisions of ASCE/SEI 7-05, including worked examples and FAQs. (ISBN 978-0-7844-0857-5)

Seismic Loads: Guide to the Seismic Load Provisions of ASCE 7-05, by Charles A.

Charney. (ASCE Press, 2010). Offers an authoritative interpretation of the seismic load provisions of ASCE/SEI 7-05, including worked examples and FAQs. (ISBN 978-0-7844-1076-9)

Also:

Wind Tunnel Studies of Buildings and Structures, 2nd Edition, by Nicholas Isyumov.

(ASCE Manual No. 67, 1999). Assists architects and engineers to improve the reliability of structural performance and to achieve cost effectiveness. (ISBN 978-0-7844-0319-2)

In the Wake of Tacoma: Suspension Bridges and the Quest for Aerodynamic Stability, by Richard Scott.

(ASCE Press, 2001). Surveys changes in the design of suspension bridges, evolving from the 1940 collapse of the first Tacoma Narrows Bridge. (ISBN 978-0-7844-0542-0)

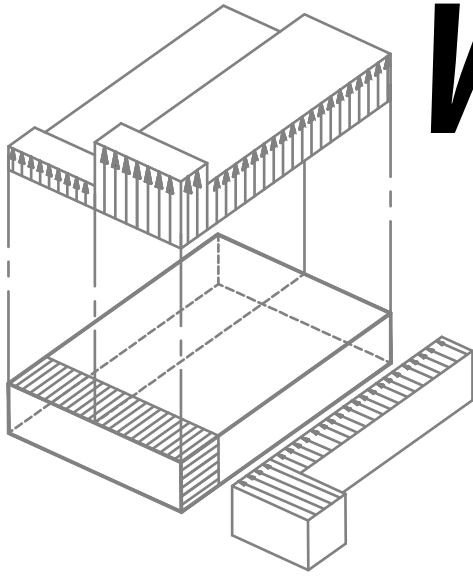

Wind Loads

Guide to the Wind Load Provisions of ASCE 7-05

Kishor C. Mehta, Ph.D., P.E.
William L. Coulbourne, P.E.

ASCE
PRESS

Library of Congress Cataloging-in-Publication Data

Mehta, Kishor C.

Wind loads : guide to the wind load provisions of ASCE 7-05 / Kishor C. Mehta, William L. Coulbourne.

p. cm.

Includes bibliographical references and index.

ISBN 978-0-7844-0858-2

1. Wind-pressure. 2. Buildings—Standards—United States. 3. Buildings—Aerodynamics. 4. Gust loads. 5. Structural engineering. I. Coulbourne, William L. II. Title.

TH891.M453 2010

690'.1—dc22

2010009410

Published by American Society of Civil Engineers

1801 Alexander Bell Drive

Reston, Virginia 20191

www.pubs.asce.org

Any statements expressed in these materials are those of the individual authors and do not necessarily represent the views of ASCE, which makes no responsibility for any statement made herein. No reference made in this publication to any specific method, product, process, or service constitutes or implies an endorsement, recommendation, or warranty thereof by ASCE. The materials are for general information only and do not represent a standard of ASCE, nor are they intended as a reference in purchase specifications, contracts, regulations, statutes, or any other legal document.

ASCE makes no representation or warranty of any kind, whether express or implied, concerning the accuracy, completeness, suitability, or utility of any information, apparatus, product, or process discussed in this publication, and assumes no liability therefor. This information should not be used without first securing competent advice with respect to its suitability for any general or specific application. Anyone utilizing this information assumes all liability arising from such use, including but not limited to infringement of any patent or patents.

ASCE and American Society of Civil Engineers—Registered in U.S. Patent and Trademark Office.

Photocopies and reprints. You can obtain instant permission to photocopy ASCE publications by using ASCE's online permission service (<http://pubs.asce.org/permissions/requests/>). Requests for 100 copies or more should be submitted to the Reprints Department, Publications Division, ASCE (address above); e-mail: permissions@asce.org. A reprint order form can be found at <http://pubs.asce.org/support/reprints/>.

Copyright © 2010 by the American Society of Civil Engineers.
All Rights Reserved.

ISBN 978-0-7844-0858-2

Manufactured in the United States of America.

18 17 16 15 14 13 12 11 10 1 2 3 4 5

Contents

Preface	viii
Table of Conversion Factors	viii
Chapter 1 Introduction	1
Objective of the Guide	2
Significant Changes and Additions	2
Limitations of Standard	3
Technical Literature	5
Chapter 2 Wind Load Provisions	7
Format	7
Design Procedures	8
Method 3, Wind Tunnel Procedure	12
Equations for Graphs	13
Chapter 3 Examples	23
Example 1: 30-ft × 60-ft × 15-ft Commercial Building with Concrete Masonry Unit Walls	23
Example 2: Example Using Simplified Procedure	31
Example 3: 100-ft × 200-ft × 160-ft High Office Building	35
Example 4: Office Building from Ex. 3 Located on an Escarpment	47
Example 5: 2,500-ft ² House with Gable/Hip Roof	50
Example 6: 200-ft × 250-ft Gable Roof Commercial/ Warehouse Building Using Buildings of All Height Provisions	59
Example 7: Building from Ex. 6 Using Low-Rise Building Provisions	72
Example 8: 40-ft × 80-ft Commercial Building with Monoslope Roof with Overhang	80
Example 9: U-Shaped Apartment Building	93
Example 10: 50-ft × 20-ft Billboard Sign on Poles (Flexible) 60 ft Above Ground	104
Example 11: Domed Roof Building	111
Example 12: Unusually Shaped Building	119
Example 13: 30-ft × 60-ft Open Building with Gable Roof	130
Chapter 4 Frequently Asked Questions	137
References	147
Index	153
About the Authors	159

Currently in preview, click buy full version

Preface

This guide is designed to assist professionals in the use of the wind load provisions of ASCE/SEI Standard 7-05, *Minimum Design Loads for Buildings and Other Structures*, published by the American Society of Civil Engineers (ASCE). The guide is a revision of the *Guide to the Use of Wind Load Provisions of ASCE 7-02*, reflecting the significant changes made to wind load provisions when the previous version of the Standard, SEI/ASCE 7-02, was updated. The guide contains 13 example problems worked out in detail, which can provide direction to practicing professionals in assessing wind loads on a variety of buildings and other structures. Every effort has been made to make these illustrative example problems correct and accurate. The authors would welcome comments regarding inaccuracies, errors, or different interpretations. The views expressed and interpretation of the wind load provisions made in the guide are those of the authors and not of the ASCE 7 Standards Committee or of the American Society of Civil Engineers.

Table of Conversion Factors

<i>U.S. customary units</i>	<i>International System of Units (SI)</i>
1 inch (in.)	25.4 millimeters (mm)
1 foot (ft)	0.3048 meter (m)
1 statute mile	1.6093 kilometers (km)
1 square foot (ft ²)	0.0929 square meter (m ²)
1 cubic foot (ft ³)	0.0283 cubic meter (m ³)
1 pound (lb)	0.4536 kilograms (kg)
1 pound (force)	4.4482 newtons (N)
1 pound per square foot (lb/ft ²)	0.0479 kilonewton per square meter (kN/m ²)
1 pound per cubic foot (lb/ft ³)	16.0185 kilograms per cubic meter (kg/m ³)
1 degree Fahrenheit (°F)	1.8 degrees Celsius (°C)
1 British thermal unit (Btu)	1.0551 kilojoules (kJ)
1 degree Fahrenheit per British thermal unit (°F/Btu)	1.7061 degrees Celsius per kilojoule (°C/kJ)

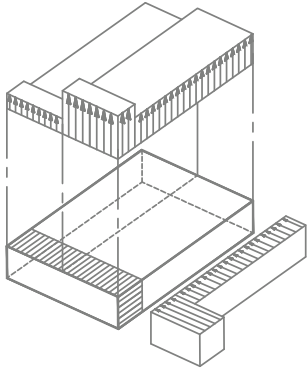

Chapter 1

Introduction

The American Society of Civil Engineers (ASCE) publication, *Minimum Design Loads for Buildings and Other Structures*, ASCE/SEI Standard 7-05, is a consensus standard. It originated in 1972 when the American National Standards Institute (ANSI) published a standard with the same title (ANSI A58.1-1972). That 1972 standard was revised ten years later, containing an innovative approach to wind loads for components and cladding (C&C) of buildings (ANSI A58.1-1982). Wind load criteria were based on the understanding of aerodynamics of wind pressures in building corners, eaves, and ridge areas, as well as the effects on pressures of area averaging.

In the mid-1980s, the ASCE assumed responsibility for the Minimum Design Loads for Buildings and Other Structures Standards Committee, which establishes design loads. The document published by ASCE (ASCE 7-88) contained design load criteria for live loads, snow loads, wind loads, earthquake loads, and other environmental loads, as well as load combinations. The ASCE 7 Standards Committee has voting membership of close to 100 individuals representing all aspects of the building construction industry. The criteria for each of the environmental loads are developed by respective task committees.

The wind load criteria of ASCE 7-88 (ASCE, 1990) were essentially the same as ANSI A58.1-1982. In 1995, ASCE published ASCE 7-95. This version contained major changes in wind load criteria: the basic wind speed averaging time was changed from fastest-mile to 3-second gust. This in turn necessitated significant changes in boundary-layer profile parameters, gust effect

factor, and some pressure coefficients. A *Guide to the Use of the Wind Load Provisions of ASCE 7-95* (Mehta and Marshall, 1998) was published by ASCE to assist practicing professionals in the use of wind load criteria of ASCE 7-95.

In 2000, ASCE published a revision of ASCE 7-95 with updated wind load provisions. The document is termed ASCE 7-98 and has the same title (ASCE, 2000). The International Building Code (ICC, 2000) adopted the wind load criteria of ASCE 7-98 by reference. This was a major milestone since it had the potential to establish a single wind load criterion for design of all buildings and structures for the entire United States. A *Guide to the Use of the Wind Load Provisions of ASCE 7-98* (Mehta and Perry, 2000) was published soon after publication of ASCE 7-98. This document was updated as *Guide to the Use of the Wind Load Provisions of ASCE 7-02* (Mehta and Delahay, 2004) after publication of the revised standard ASCE 7-02.

In 2005, the new standard, ASCE 7-05, was published. This guide is designed to assist practicing professionals in the use of wind load criteria of ASCE 7-05.

1.1 Objective of the Guide

The objective of this guide is to provide direction in the use of wind load provisions of ASCE 7-05 (referred to as “the Standard”). The Commentary of ASCE 7-05 (Chapter C6) contains a good background and discussion of the wind load criteria; that information is not repeated in this document. Rather, this guide contains two important items to assist the users of ASCE 7-05: (1) examples, and (2) frequently asked questions.

The guide contains 13 worked examples. Sufficient details of calculation of wind loads are provided to help the reader properly interpret the wind load provisions of the Standard. Chapter 6 of the Standard, as well as the figures and tables of the Standard, are cited liberally in the examples. **It is necessary to have a copy of ASCE 7-05 to follow the examples and work with this guide.** A copy of ASCE 7-05 can be ordered by calling 1-800-548-ASCE or on the Internet at www.pubs.asce.org.

1.2 Significant Changes and Additions

The wind load provisions of Chapter 6.0 were revised in ASCE 7-05 using recent research and development achievements. The major additions involve roof pressures over open buildings, loads on rooftop equipment, and expansion of the commentary.

The basic approach to assessing wind loading has not been changed. Significant changes/additions can assist the design process and are listed below.

- Simplified procedure for MWFRS is permitted only if torsion loading consideration is exempted or does not control.

- Simplified procedure is permitted for hilly terrain if topographic effects are taken into account.
- Upwind distances are changed for Exposures B and D.
- In wind-borne debris regions, impact resistant glazing or protective covering in the bottom 60 ft of buildings is made mandatory.
- Parapet pressure coefficients for MWFRS loading are revised.
- For open buildings, pressure coefficients for monoslope, pitched and troughed roofs are added.
- Force coefficients for freestanding solid walls and signs are added.
- Rooftop equipment wind load provisions for buildings less than 60 ft are added.
- Commentary Chapter C6 for wind loads is expanded to provide guidance in hurricane wind speeds, torsional sensitivity of buildings, assessment of fundamental frequency, and other items.

As noted above, the basic methodology of the Standard remains the same as in ASCE 7-02. Additional information on the changes can be found in the Commentary of the Standard and from references.

1.3 Limitations of Standard

The possible shortcomings or limitations of the Standard are directly dependent on accurate knowledge of parameters and factors used in the algorithms that define the wind loads for design applications. Limitations of some of the significant parameters are given below.

1.3.1 Assessment of Wind Climate

The current Standard provides a more realistic description of wind speeds than did the previous editions of the 1970s and 1980s. Perhaps the most serious limitations are that design speeds are not referenced to direction, and potential wind speed anomalies are defined only in terms of special wind regions. These special wind regions include mountain ranges, gorges, or river valleys. Unusual winds may be encountered in these regions because of orographic effects or because of the channeling of wind. The Standard permits climatological studies using regional climatic data and consultation with a wind engineer and/or a meteorologist.

Tornado winds are not included in development of the basic wind speed map (Figure 6-1 of the Standard) because of their relatively rare occurrence at a given location. Intense tornadoes can have ground level wind speeds in the range of 150 to 200 mph; however, the annual probability of exceedance of this range of wind speeds may be less than 1×10^{-5} (mean recurrence interval exceeding 100,000 years). Special structures and storm shelters can be designed to resist tornado winds if required.

1.3.2 Limitations in Evaluating Structural Response

Given that the majority of buildings and other structures can be treated as rigid structures, the gust effect factor specified in the Standard is adequate. For dynamically sensitive buildings and other structures, a gust effect factor, G_f , is given. The formulation of gust effect factor, G_f , is primarily for buildings; it is not always applicable to other structures. It should be noted that the gust effect factor, G_f , is based on along-wind buffeting response.

Vortex shedding is almost always present with bluff-shaped cylindrical bodies. It can become a problem when the frequency of shedding is close to, or equal to, the frequency of the first or second transverse modes of the structure. The intensity of excitation increases with aspect ratio (height-to-width or length-to-breadth) and decreases with increasing structural damping. Structures with low damping and with an aspect ratio of 8 or more may be prone to damaging vortex excitation. If across-wind or torsional excitation appears to be a possibility, expert advice should be obtained.

Another limitation with respect to evaluating structural response is that the Standard does not define acceptable design wind speeds for serviceability states (e.g., deflection, dynamic sway). Table C6-7 in the Commentary provides conversion factors for determining appropriate wind speeds for mean recurrence intervals of 5 to 500 yr.

1.3.3 Limitations in Shapes of Buildings and Other Structures

The pressure and force coefficients given in the Standard are limited. Many of the structural shapes (e.g., “Y,” “T,” and “L” shapes) or buildings with stepped elevations are not included (except as shown in Figure 6-12). Fortunately, this information may be found in other sources (see **Table G1-1** of this guide).

When coefficients for a specific shape are not given in the Standard, the designer is encouraged to use values that are available in the literature. However, the use of prudent judgment is advised, and the following caveats must be addressed:

1. Were the coefficients obtained from proper turbulent boundary layer wind tunnel (BLWT) tests, or were they generated under conditions of relatively smooth flow?
2. The averaging time used must necessarily be considered in order to determine whether the coefficients are directly applicable to the evaluation of design loads or whether they need to be modified.
3. The reference wind speed (fastest-mile, hourly mean, 10-min mean, 3-s gust, etc.) and exposure category under which the data are generated must be established in order to properly compute the velocity pressure, q .
4. If an envelope approach is used, the coefficients should be appropriate for all wind directions. If, however, a directional approach is indicated, then the applicability of the coefficients as a function of wind direction needs to be ascertained. A major limitation in the