

AS 61869.15:2021



STANDARDS
Australia



Instrument transformers

Part 15: Additional requirements for voltage transformers for DC applications (IEC 61869-15:2018 (ED 1.0) MOD)

currently in preview, click buy full version

AS 61869.15:2021

This Australian Standard® was prepared by EL-013, Measurement and Protection Transformers. It was approved on behalf of the Council of Standards Australia on 11 February 2021.

This Standard was published on 26 February 2021.

The following are represented on Committee EL-013:

Australian Industry Group
Energy Networks Australia
Engineers Australia
National Measurement Institute
University of South Australia

This Standard was issued in draft form for comment as DR AS 61869.15:2020.

Keeping Standards up-to-date

Ensure you have the latest versions of our publications and keep up-to-date about Amendments, Rulings, Withdrawals, and new projects by visiting:

www.standards.org.au

ISBN 978 1 76113 223 0

Instrument transformers

Part 15: Additional requirements for voltage transformers for DC applications (IEC 61869-15:2018 (ED 1.0) MOD)

First published as AS 61869.15:2021



© IEC 2021 — All rights reserved
© Standards Australia Limited 2021

All rights are reserved. No part of this work may be reproduced or copied in any form or by any means, electronic or mechanical, including photocopying, without the written permission of either the IEC or the publisher, unless otherwise permitted under the Copyright Act 1968 (Cth). If you have any questions about IEC copyright or have an enquiry about obtaining additional rights to this publication, please see the contact details on the back cover or the contact us page of the website for further information.

Preface

This Standard was prepared by the Standards Australia Committee EL-013, Measurement and Protection Transformers.

The objective of this document is to provide all requirements specific to voltage transformers to be used in DC applications (DCVTs), whatever the technology used. The output signal can be analogue or digital.

It is applicable to newly manufactured voltage transformers used for measuring, protection and/or control applications in DC power systems with a rated voltage above 1.5 kV.

This document covers passive voltage dividers as well as active voltage transformers, used for measurement, control and protection.

This document is an adoption with national modifications, and has been reproduced from, IEC 61869-15:2018, *Instrument transformers — Part 15: Additional requirements for voltage transformers for DC applications*.

The modifications are additional requirements and are set out in [Appendix ZZ](#), which has been added at the end of the source text.

[Appendix ZZ](#) lists the variations to IEC 61869-15:2018 for the application of this document in Australia.

As this document has been reproduced from an International Standard, the following applies:

- (a) In the source text “this part of 61869” should read “this document”.
- (b) A full point substitutes for a comma when referring to a technical marker.

Australian or Australian/New Zealand Standards that are identical adoptions of international normative references may be used interchangeably. Refer to the online catalogue for information on specific Standards.

The terms “normative” and “informative” are used in Standards to define the application of the appendices or annexes to which they apply. A “normative” appendix or annex is an integral part of a Standard, whereas an “informative” appendix or annex is only for information and guidance.

NOTES

Currently in preview, click buy full version

CONTENTS

FOREWORD.....	3
INTRODUCTION.....	6
1 Scope.....	8
2 Normative references	8
3 Terms, definitions, abbreviated terms and symbols.....	8
5 Ratings.....	12
6 Design and construction	15
7 Tests	20
Annex 15A (informative) Proposed rated insulation level applicable to voltage transformers for DC application.....	34
Bibliography.....	35
Figure 1501 – Position of the DCVT's in the DC scheme.....	6
Figure 1502 – Typical step responses of a system	10
Figure 1503 – Accuracy limits of a DCVT	14
Figure 1504 – RC divider with low-voltage part outside the main housing	25
Figure 1505 – Connection for voltage withstand test of the external low voltage part of a DCVT.....	26
Figure 1506 – Polarity reversal test profile.....	27
Figure 1507– Measurement of the step response time	29
Table 1501 – Voltage on DCVT's	6
Table 3 – Partial discharge test voltages and permissible levels	13
Table 1502 – Limits of ratio error for DCVT (classes from 0,1 to 3).....	14
Table 7 – Static withstand test load	16
Table 8 – Arc fault duration and performance criteria	17
Table 1503 – Markings of terminals	18
Table 1504 – Rating plate marking for common rating plate	19
Table 1505 – Rating plate marking for each secondary converter	19
Table 1506 – Rating plate marking for auxiliary power supply	20
Table 10 – Life tests.....	21
Table 15A.1 – Proposed rated primary terminal insulation levels for voltage transformers for DC application.....	34

INTERNATIONAL ELECTROTECHNICAL COMMISSION

INSTRUMENT TRANSFORMERS –

Part 15: Additional requirements for
voltage transformers for DC applications

FOREWORD

- 1) The International Electrotechnical Commission (IEC) is a worldwide organization for standardization comprising all national electrotechnical committees (IEC National Committees). The object of IEC is to promote international co-operation on all questions concerning standardization in the electrical and electronic fields. To this end and in addition to other activities, IEC publishes International Standards, Technical Specifications, Technical Reports, Publicly Available Specifications (PAS) and Guides (hereafter referred to as "IEC Publication(s)"). Their preparation is entrusted to technical committees; any IEC National Committee interested in the subject dealt with may participate in this preparatory work. International, governmental and non-governmental organizations liaising with the IEC also participate in this preparation. IEC collaborates closely with the International Organization for Standardization (ISO) in accordance with conditions determined by agreement between the two organizations.
- 2) The formal decisions or agreements of IEC on technical matters express, as nearly as possible, an international consensus of opinion on the relevant subjects since each technical committee has representation from all interested IEC National Committees.
- 3) IEC Publications have the form of recommendations for international use and are accepted by IEC National Committees in that sense. While all reasonable efforts are made to ensure that the technical content of IEC Publications is accurate, IEC cannot be held responsible for the way in which they are used or for any misinterpretation by any end user.
- 4) In order to promote international uniformity, IEC National Committees undertake to apply IEC Publications transparently to the maximum extent possible in their national and regional publications. Any divergence between any IEC Publication and the corresponding national or regional publication shall be clearly indicated in the latter.
- 5) IEC itself does not provide any attestation of conformity. Independent certification bodies provide conformity assessment services and, in some areas, accept IEC marks of conformity. IEC is not responsible for any services carried out by independent certification bodies.
- 6) All users should ensure that they have the latest edition of this publication.
- 7) No liability shall attach to IEC or its directors, employees, servants or agents including individual experts and members of its technical committees and IEC National Committees for any personal injury, property damage or other damage of any nature whatsoever, whether direct or indirect, or for costs (including legal fees) and expenses arising out of the publication, use of, or reliance upon, this IEC Publication or any other IEC Publications.
- 8) Attention is drawn to the normative references cited in this publication. Use of the referenced publications is indispensable for the correct application of this publication.
- 9) Attention is drawn to the possibility that some of the elements of this IEC Publication may be the subject of patent rights. IEC shall not be held responsible for identifying any or all such patent rights.

International Standard IEC 61869-15 has been prepared by IEC technical committee 38: Instrument transformers.

The text of this standard is based on the following documents:

FDIS	Report on voting
38/561/FDIS	38/566/RVD

Full information on the voting for the approval of this International Standard can be found in the report on voting indicated in the above table.

This document has been drafted in accordance with the ISO/IEC Directives, Part 2.

A list of all parts in the IEC 61869 series, published under the general title *Instrument transformers*, can be found on the IEC website.

This Part 15 is to be used in conjunction with IEC 61869-1:2007, *General Requirements*, and IEC 61869-6:2016, *Additional general requirements for low-power instrument transformers* – however, the reader is encouraged to use the most recent edition.

This Part 15 follows the structure of IEC 61869-1:2007 and IEC 61869-6:2016 and supplements or modifies their corresponding clauses.

When a subclause of Part 1 or Part 6 is not mentioned in this Part 15, that subclause applies. When this standard states "addition", "modification" or "replacement", the relevant text in Part 1 or Part 6 is to be adapted accordingly.

For additional clauses, subclauses, figures, tables, annexes or notes, the following numbering system is used:

- clauses, subclauses, tables, figures and notes that are numbered starting from 1501 are additional to those in Part 1 and Part 6;
- additional annexes are lettered 15A, 15B, etc.

An overview of the planned set of standards at the date of publication of this document is given below. The updated list of standards issued by IEC TC 48 is available at the website: www.iec.ch.

PRODUCT FAMILY STANDARDS	PRODUCT STANDARD	PRODUCTS	OLD STANDARD	
61869-1 GENERAL REQUIREMENTS	61869-2	ADDITIONAL REQUIREMENTS FOR CURRENT TRANSFORMERS	60044-1 60044-6	
	61869-3	ADDITIONAL REQUIREMENTS FOR INDUCTIVE VOLTAGE TRANSFORMERS	60044-2	
	61869-4	ADDITIONAL REQUIREMENTS FOR COMBINED TRANSFORMERS	60044-3	
	61869-5	ADDITIONAL REQUIREMENTS FOR CAPACITIVE VOLTAGE TRANSFORMERS	60044-5	
	61869-6 ADDITIONAL GENERAL REQUIREMENT FOR LOW-POWER INSTRUMENT TRANSFORMERS	61869-7	ADDITIONAL REQUIREMENTS FOR ELECTRONIC VOLTAGE TRANSFORMERS	60044-7
		61869-8	ADDITIONAL REQUIREMENTS FOR ELECTRONIC CURRENT TRANSFORMERS	60044-8
		61869-9	DIGITAL INTERFACE FOR INSTRUMENT TRANSFORMERS	
		61869-10	ADDITIONAL REQUIREMENTS FOR LOW-POWER PASSIVE CURRENT TRANSFORMERS	
		61869-11	ADDITIONAL REQUIREMENTS FOR LOW-POWER PASSIVE VOLTAGE TRANSFORMERS	60044-7
		61869-12	ADDITIONAL REQUIREMENTS FOR COMBINED ELECTRONIC INSTRUMENT TRANSFORMER OR COMBINED LOW-POWER PASSIVE TRANSFORMERS	
		61869-13	STAND ALONE MERGING UNIT	
		61869-14	ADDITIONAL REQUIREMENTS FOR CURRENT TRANSFORMERS FOR DC APPLICATIONS	
		61869-15	ADDITIONAL REQUIREMENTS FOR VOLTAGE TRANSFORMERS FOR DC APPLICATIONS	

The committee has decided that the contents of this document will remain unchanged until the stability date indicated on the IEC website under "<http://webstore.iec.ch>" in the data related to the specific document. At this date, the document will be

- reconfirmed,
- withdrawn,
- replaced by a revised edition, or
- amended.

IMPORTANT – The 'colour inside' logo on the cover page of this publication indicates that it contains colours which are considered to be useful for the correct understanding of its contents. Users should therefore print this document using a colour printer.

INTRODUCTION

This document applies to voltage transformers (VT) intended to be used in DC applications with the following functions:

- measure DC voltage (with significant harmonics);
- withstand DC voltage.

Two main technologies of DC converters exist today: LCC and VSC

- Line-commutated converters (LCC) are based on thyristor converters. They are characterized by a single direction of current flow, and a voltage polarity reversal possibility. Significant voltage and current harmonics exist up to frequencies of about 3 kHz to 4 kHz.
- Voltage source converters (VSC) are based on transistor converters. They are characterized by a bi-directional current flow and a single voltage polarity. Voltage and current harmonics exist up to frequencies of about 20 kHz.

The position of the DCVTs on the DC system is illustrated in Figure 1501.

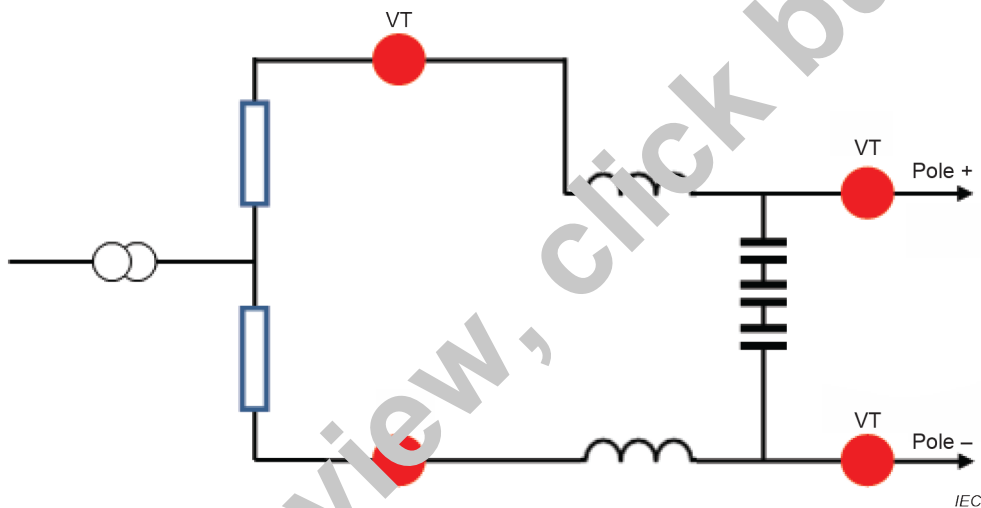

Figure 1501 - Position of the DCVT's in the DC scheme

Table 1501 gives an overview of the voltage waveshape as well as the main characteristics of the VT.

Table 1501 - Voltage on DCVT's

Voltage	Characteristics
	<ul style="list-style-type: none"> Pure DC application High-accuracy measurement Harmonics measurement Metering, control and protection purpose

The actual technology used for DCVT's are resistive voltage dividers (with or without additional capacitance). However, other technologies could be used in the future (for example, optical voltage sensors).

This document includes some specific requirements applicable to resistive voltage dividers, but can be applied to any technology.

INSTRUMENT TRANSFORMERS –

Part 15: Additional requirements for voltage transformers for DC applications

1 Scope

This part of IEC 61869 provides all requirements specific to voltage transformers to be used in DC applications (DCVTs), whatever the technology used. The output signal can be analogue or digital.

It is applicable to newly manufactured voltage transformers used for measuring, protection and/or control applications in DC power systems with a rated voltage above 1,5 kV.

This document covers passive voltage dividers as well as active voltage transformers, used for measurement, control and protection.

The general configuration of a single-pole low-power instrument transformer is described in Figure 601 of IEC 61869-6:2016.

2 Normative references

The following documents are referred to in the text in such a way that some or all of their content constitutes requirements of this document. For dated references, only the edition cited applies. For undated references, the latest edition of the referenced document (including any amendments) applies.

Clause 2 of IEC 61869-6:2016 is applicable, with the following additions:

IEC TS 60815-4:2016, *Selection and dimensioning of high-voltage insulators intended for use in polluted conditions – Part 4: Insulators for DC systems*

IEC TS 61245, *Artificial pollution tests on high-voltage ceramic and glass insulators to be used on DC systems*

IEC 61869-1:2007, *Instrument transformers – Part 1: General requirements*

IEC 61869-6:2016, *Instrument transformers – Part 6: Additional general requirements for low-power instrument transformers*

IEC 61869-9:2016, *Instrument transformers – Part 9: Digital interface for instrument transformers*

3 Terms, definitions, abbreviated terms and symbols

For the purposes of this document, the terms and definitions given in Clause 3 of IEC 61869-1:2007, of IEC 61869-6:2016 and of IEC 61869-9:2016 are applicable with the following additions and modifications.

ISO and IEC maintain terminological databases for use in standardization at the following addresses: