

Australian Standard[®]

Ride-on lawn mowers

**Part 1: Powered rotary ride-on
mowers**

This Australian Standard was prepared by Committee CS/33, Power Lawnmowers and Edge Trimmers. It was approved on behalf of the Council of Standards Australia on 27 June 1990 and published on 12 November 1990.

The following interests are represented on Committee CS/33:

Attorney-General's Department
Australian Federation of Consumer Organizations
Business and Consumer Affairs, N.S.W.
Confederation of Australian Industry
Department of Public and Consumer Affairs, S.A.
Local Government Association of New South Wales
Metal Trades Industry Association of Australia
Mower Specialists Association of Australia
National Safety Council of Australia (Federal Secretariat)
Outdoor Power Equipment Association
The WorkCover Authority, N.S.W.

Review of Australian Standards. To keep abreast of progress in industry, Australian Standards are subject to periodic review and are kept up to date by the issue of amendments or new editions as necessary. It is important therefore that Standards users ensure that they are in possession of the latest edition, and any amendments thereto.

Full details of all Australian Standards and related publications will be found in the Standards Australia Catalogue of Publications; this information is supplemented each month by the magazine 'The Australian Standard', which subscribing members receive, and which gives details of new publications, new editions and amendments, and of withdrawn Standards.

Suggestions for improvements to Australian Standards, addressed to the head office of Standards Australia, are welcomed. Notification of any inaccuracy or ambiguity found in an Australian Standard should be made without delay in order that the matter may be investigated and appropriate action taken.

This Standard was issued in draft form for comment as DR 89157.

Australian Standard[®]

Ride-on lawnmowers

**Part 1: Powered rotary ride-on
mowers**

First published as AS 3792.1—1990.
Incorporating:
Amdt 1—1991

PREFACE

This Standard was prepared by the Standards Australia Committee on Power Lawnmowers and Edge Trimmers in response to a request from a manufacturer of ride-on lawnmowers. This request was for a Standard establishing safety requirements for ride-on mowers with emphasis on safety for the user and bystander.

The Standard is based on AS 2657—1985 with additional requirements being taken from ISO/DP 5395 to cater for the ride-on characteristics.

It forms Part 1 of a series on ride-on lawnmowers. The powered rotary type of ride-on mower covered by this Standard accounts for the majority of ride-on mowers purchased for domestic use.

© Copyright — STANDARDS AUSTRALIA

Users of Standards are reminded that copyright subsists in all Standards Australia publications and software. Except where the Copyright Act allows and except where provided for below no publications or software produced by Standards Australia may be reproduced, stored in a retrieval system in any form or transmitted by any means without prior permission in writing from Standards Australia. Permission may be conditional on an appropriate royalty payment. Requests for permission and information on commercial software royalties should be directed to the head office of Standards Australia.

Standards Australia will permit up to 10 percent of the technical content pages of a Standard to be copied for use exclusively in-house by purchasers of the Standard without payment of a royalty or advice to Standards Australia.

Standards Australia will also permit the inclusion of its copyright material in computer software programs for no royalty payment provided such programs are used exclusively in-house by the creators of the programs.

Care should be taken to ensure that material used is from the current edition of the Standard and that it is updated whenever the Standard is amended or revised. The number and date of the Standard should therefore be clearly identified.

The use of material in print form or in computer software programs to be used commercially, with or without payment, or in commercial contracts is subject to the payment of a royalty. This policy may be varied by Standards Australia at any time.

CONTENTS

	<i>Page</i>
SECTION 1 SCOPE AND GENERAL	
1.1 SCOPE	4
1.2 REFERENCED DOCUMENTS	4
1.3 DEFINITIONS	4
SECTION 2 DESIGN REQUIREMENTS	
2.1 BLADES	6
2.2 BLADE MOUNTINGS	6
2.3 PROTECTIVE GUARDING	6
2.4 CONTROLS	6
2.5 ELECTRICAL REQUIREMENTS	7
2.6 TRANSPORT	7
2.7 BRAKES	7
SECTION 3 PERFORMANCE REQUIREMENTS	
3.1 BLADE STOPPING TIME	8
3.2 OVERLOAD PROTECTION	8
3.3 ACCESSIBILITY	8
3.4 FOOT PROBE	8
3.5 IMPACT	8
3.6 UNBALANCE	8
3.7 STRUCTURAL INTEGRITY	8
3.8 THROWN OBJECT	8
3.9 BRAKING PERFORMANCE	8
3.10 STABILITY	8
SECTION 4 DOCUMENTATION AND MARKING	
4.1 SAFETY INSTRUCTIONS	9
4.2 SAFETY SIGNS AND LABELS	9
4.3 DOCUMENTATION	9
4.4 MARKING	9
APPENDICES	
A ACCESSIBILITY	10
B FOOT PROBE TEST	11
C PRECONDITIONING PROCEDURE FOR IMPACT AND STRUCTURAL INTEGRITY TYPE TESTS	14
D IMPACT TEST	15
E UNBALANCE TEST	17
F STRUCTURAL INTEGRITY TEST	18
G CORRUGATED FIBREBOARD PENETRATION TEST	20
H THROWN OBJECT TEST	22
I SERVICE BRAKE SYSTEM TEST	27
J PARKING BRAKE SYSTEM TEST	28
K STABILITY TEST	29
L SAFETY INSTRUCTIONS	31

STANDARDS AUSTRALIA

Australian Standard
Ride-on lawnmowers

Part 1: Powered rotary ride-on mowers

SECTION 1 SCOPE AND GENERAL

1.1 SCOPE This Standard specifies design and performance requirements relating to the safety of powered rotary lawnmowers of the ride-on type up to a size limit of 1250 mm width of cut.

This Standard does not apply to lawn trimmers, lawn edge trimmers, and edgers, flail mowers, sickle-bar mowers or mowers with a width of cut greater than 1250 mm.

NOTE: Requirements for powered rotary lawnmowers of the walk-behind type are specified in AS 2657.

1.2 REFERENCED DOCUMENTS The documents below are referred to in this Standard:

AS	
2657	Powered rotary lawnmowers
2953	Earth-moving machinery — Human dimensions
2953.2	Part 2: Physical dimensions of operators and minimum operator space envelope
3156	Approval and test specification — Electric lawnmowers
ISO	
3304	Plain end seamless precision steel tubes — Technical conditions for delivery
3305	Plain end welded precision steel tubes — Technical conditions for delivery
3306	Plain end as-welded and sized precision steel tubes — Technical conditions for delivery
3767	Tractors, machinery for agriculture and forestry, powered lawn and garden equipment— Symbols for operator controls and other displays
3767.1	Part 1: Common symbols
3767.2	Part 2: Symbols for agricultural tractors and machinery
3767.3	Part 3: Symbols for powered lawn and garden equipment
4200	Plain end steel tubes, welded and seamless — General tables of dimensions and masses per unit length

1.3 DEFINITIONS For the purpose of this Standard, the definitions below apply.

1.3.1 Blade tip circle—the path described by the outermost point of the cutting edge of the cutting blades as it rotates about its shaft axis.

1.3.2 Blades—the mechanism used to provide the cutting action of a power lawnmower including both metal and non-metal cutting means.

1.3.3 Cutting area of the blades—the area of the blades which lies in the annulus between the blade tip circle and a concentric circle which has a diameter which is 80 percent of that of the blade tip circle (see Figure 1).

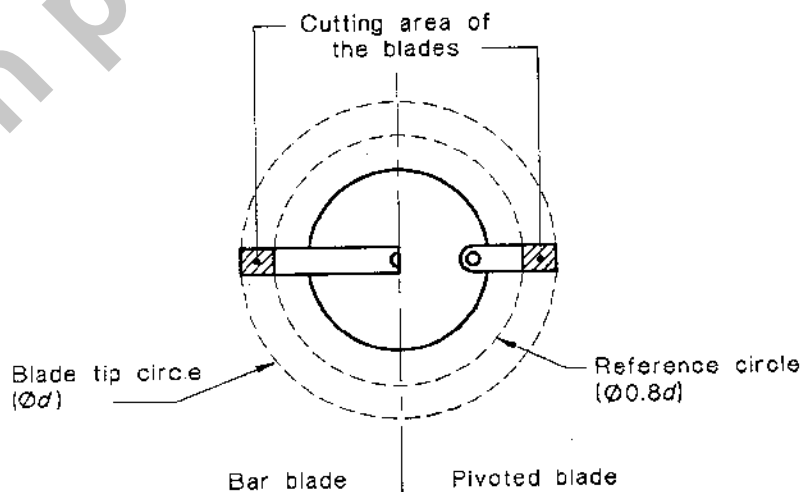

FIGURE 1 CUTTING AREA OF THE BLADES