

Australian Standard<sup>®</sup>

---

**POWERED ROTARY  
LAWNMOWERS**

---

This Australian Standard was prepared by Committee CS/33, Power Lawnmowers and Edge Trimmers. It was approved on behalf of the Council of the Standards Association of Australia on 6 August 1985 and published on 4 October 1985.

---

The following interests are represented on Committee CS/33:

Australian Federation of Consumer Organizations  
Confederation of Australian Industry  
Department of Consumer Affairs, N.S.W.  
Department of Employment and Labour Relations, Qld.  
Department of Industrial Relations, N.S.W.  
Department of Main Roads, N.S.W.  
Interstate Noise Control Committee  
Local Government Association of New South Wales  
Metal Trades Industry Association of Australia  
Mower Specialists Association of Australia  
National Safety Council of Australia (Victorian Division)

---

**Review of Australian Standards.** To keep abreast of progress in industry, Australian Standards are subject to periodic review and are kept up to date by the issue of amendments or new editions as necessary. It is important therefore that Standards users ensure that they are in possession of the latest edition, and any amendments, etc.

Full details of all Australian Standards and related publications will be found in the Standards Australia Catalogue of Publications; this information is supplemented each month by the magazine 'The Australian Standard', which subscribing members receive, and which gives details of new publications, new editions and amendments, and of withdrawn Standards.

Suggestions for improvements to Australian Standards, addressed to the head office of Standards Australia, are welcomed. Notification of any inaccuracy or ambiguity found in an Australian Standard should be made without delay in order that the matter may be investigated and appropriate action taken.

---

Australian Standard<sup>®</sup>

---

**POWERED ROTARY  
LAWNMOWERS**

---

First published (as AS B280) .....	1969
Revised and issued as AS 2657 .....	1983
Second edition .....	1985

PUBLISHED BY STANDARDS AUSTRALIA  
(STANDARDS ASSOCIATION OF AUSTRALIA)  
1 THE CRESCENT, HOMEBUSH, NSW 2140

ISBN 0 7262 3894 5

## PREFACE

This standard was prepared by the Association's Committee on Power Lawnmowers and Edge Trimmers. It supersedes AS 2657—1983 Powered Rotary Lawnmowers. Preparation of this edition was considered necessary to overcome some anomalies in the testing procedures. The revised procedures in this edition can be considered to achieve a higher level of safety than those which have been superseded.

The standard specifies requirements for the design and construction of the mower with the emphasis on safety for the user and the bystander, while consistent with the permitting of satisfactory performance in the intended task of cutting and catching grass. Throughout the preparation of this edition particular consideration was given to the safety of the operator while in control of the mower, and for this purpose, suitable test methods are specified in order to limit the possibility of accidental contact with the blades, and to control the dangerous ejection of objects from the mower. Tests for blades and their means of attachment are included to ensure that they are sufficiently robust to withstand all conditions which may occur in the normal use of a mower.

This standard is based on ISO 5395.

© Copyright — STANDARDS AUSTRALIA

Users of Standards are reminded that copyright subsists in all Standards Australia publications and software. Except where the Copyright Act allows and except where provided for below no publications or software produced by Standards Australia may be reproduced, stored in a retrieval system in any form or transmitted by any means without prior permission in writing from Standards Australia. Permission may be conditional on an appropriate royalty payment. Requests for permission and information on commercial software royalties should be directed to the head office of Standards Australia.

Standards Australia will permit up to 10 percent of the technical content pages of a Standard to be copied for use exclusively in-house by purchasers of the Standard without payment of a royalty or advice to Standards Australia.

Standards Australia will also permit the inclusion of its copyright material in computer software programs for no royalty payment provided such programs are used exclusively in-house by the creators of the programs.

Care should be taken to ensure that material used is from the current edition of the Standard and that it is updated whenever the Standard is amended or revised. The number and date of the Standard should therefore be clearly identified.

The use of material in print form or in computer software programs to be used commercially, with or without payment, or in commercial contracts is subject to the payment of a royalty. This policy may be varied by Standards Australia at any time.

## CONTENTS

	<i>Page</i>
SECTION 1. SCOPE AND GENERAL	
1.1 Scope . . . . .	4
1.2 Application . . . . .	4
1.3 Referenced Documents . . . . .	4
1.4 Definitions . . . . .	4
1.5 Electrical Safety Requirements . . . . .	4
SECTION 2. CONSTRUCTIONAL REQUIREMENTS	
2.1 Blades . . . . .	5
2.2 Blade Mountings . . . . .	5
2.3 Handle . . . . .	5
2.4 Cut-out Switch . . . . .	5
2.5 Power Controls . . . . .	5
SECTION 3. TEST REQUIREMENTS	
3.1 Accessibility . . . . .	5
3.2 Foot Probe Test . . . . .	5
3.3 Impact Test . . . . .	5
3.4 Unbalance Test . . . . .	5
3.5 Reverse Torque Test . . . . .	5
3.6 Structural Integrity Test . . . . .	5
3.7 Thrown Object Test . . . . .	5
SECTION 4. SAFETY INSTRUCTIONS AND MARKING	
4.1 Safety Instructions . . . . .	6
4.2 Marking . . . . .	6
4.3 Warning Notice . . . . .	6
APPENDICES	
A Accessibility . . . . .	7
B Foot Probe Test . . . . .	8
C Preconditioning Procedure for Impact and Structural Integrity Type Tests . . . . .	10
D Impact Test . . . . .	11
E Unbalance Test . . . . .	13
F Reverse Torque Test . . . . .	14
G Structural Integrity Test . . . . .	15
H Corrugated Fibreboard Penetration Test . . . . .	17
J Thrown Object Test . . . . .	19
K Safety Instructions . . . . .	22

## SECTION 1. SCOPE AND GENERAL

**1.1 SCOPE.** This standard specifies requirements for the construction and design of powered rotary lawnmowers, together with appropriate test methods for qualitatively assessing the robustness of the cutting means and their means of attachment.

The standard does not include performance requirements for lawnmowers other than those relating to safety.

**1.2 APPLICATION.** This standard applies to powered rotary lawnmowers of the walk-behind type intended essentially for domestic use.

It does not apply to powered cylinder type lawnmowers or powered lawnmowers of the ride-on type.

**1.3 REFERENCED DOCUMENTS.** The following documents are referred to in this standard:

AS 1074 Steel Tubes and Tubulars Threaded or Suitable for Threading with Pipe Threads of Whitworth Form

AS 3156 Approval and Test Specification for Electric Lawnmowers

**1.4 DEFINITIONS.** For the purpose of this standard the following definitions apply:

**1.4.1 Powered rotary lawnmower**—a mower incorporating one or more blade assemblies in which the cutting edge or edges are in a substantially horizontal plane and driven in rotation about a vertical axis at

such a speed that will, under normal operating conditions, cut grass.

NOTE: Throughout this standard the term 'mower' is to be taken to mean 'powered rotary lawnmower'.

**1.4.2 Blade**—the means by which grass is cut including both metal and non-metal cutting means.

**1.4.3 Blade tip circle**—a circle described by the outermost point of a fully extended blade as it rotates about its vertical axis.

**1.4.4 Swing-over handle**—a handle which may be pivoted from one end of a mower to the other to permit reversing the direction of travel of the mower without turning the mower around.

**1.4.5 Maximum speed**—the maximum rotational speed of the blade assembly attained under no-load conditions using the controls provided for the operator.

**1.4.6 Cutting area of the blades**—the area of the blades which lies in the annulus between the blade tip circle and a concentric circle which has a diameter which is 80 percent of that of the blade tip circle (see Fig. 1).

**1.5 ELECTRICAL SAFETY REQUIREMENTS.**

This standard does not include the electrical safety requirements which must be observed to secure approval for connection or sale of mowers. An electrically powered rotary lawnmower shall, in addition to complying with this standard, comply with the requirements of AS 3156.

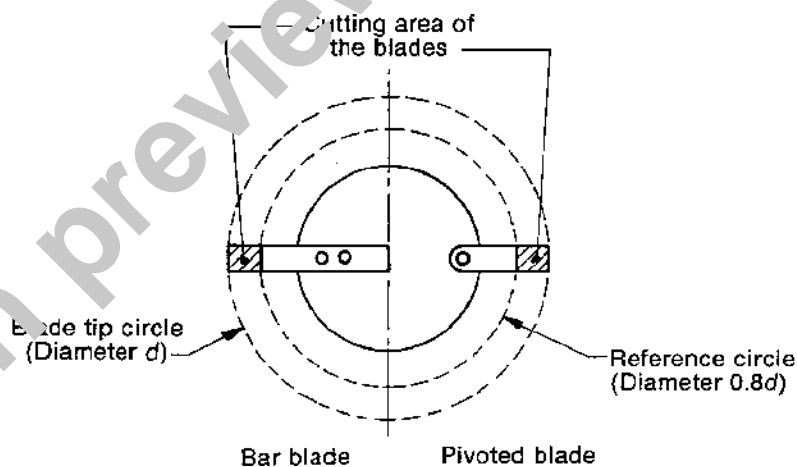

Fig. 1. CUTTING AREA OF THE BLADES