

Superseded by 2657-1985

AS 2657—1983
UDC 631.352.93

Australian Standard 2657—1983

POWERED ROTARY LAWNMOWERS

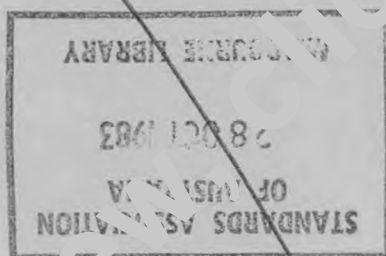

STANDARDS ASSOCIATION OF AUSTRALIA
Incorporated by Royal Charter

This Australian standard was prepared by Committee CS/33, Power Lawn Mowers and Edge Trimmers. It was approved on behalf of the Council of the Standards Association of Australia on 16 August 1983 and published on 7 October 1983.

The following interests are represented on Committee CS/33:

Australian Federation of Consumer Organizations
Confederation of Australian Industry
Department of Consumer Affairs, N.S.W.
Department of Employment and Labour Relations, Qld.
Department of Industrial Relations, N.S.W.
Department of Main Roads, N.S.W.
Interstate Noise Control Committee
Local Government Association of New South Wales
Metal Trades Industry Association of Australia
Mower Specialists Association of Australia
National Safety Council of Australia (Victorian Division)

Review of Australian Standards. To keep abreast of progress in industry, Australian standards are subject to periodic revision and are kept up-to-date by the issue of amendments or new editions as necessary. It is important therefore that standards users ensure that they are in possession of the latest edition, and any amendments thereto.

Full details of all SAA publications will be found in the Annual List of Australian Standards; this information is supplemented each month by SAA's journal 'The Australian Standard', which subscribing members receive, and which gives details of new publications, new editions and amendments, and of withdrawn standards.

Suggestions for improvements to Australian standards, addressed to the head office of the Association, are welcomed. Notification of any inaccuracy or ambiguity found in an Australian standard should be made without delay in order that the matter may be investigated and appropriate action taken.

This standard was issued in draft form for comment as DR 82060.

AUSTRALIAN STANDARD

**POWERED ROTARY
LAWNMOWERS**

AS 2657-1983

| | |
|-------------------------------------|------|
| First published (as AS B280) | 1969 |
| Revised and issued as AS 2657 | 1983 |

**PUBLISHED BY THE STANDARDS ASSOCIATION OF AUSTRALIA
STANDARDS HOUSE, 80 ARTHUR ST, NORTH SYDNEY, N.S.W.**

ISBN 0 7262 3159 2

PREFACE

This standard was prepared by the Association's Committee on Power Lawn Mowers and Edge Trimmers to supersede AS B280—1969. Preparation of this new edition was considered necessary to bring the standard into line with the International standard ISO 5395 and to metricate the standard. Other changes have been made in view of trends in mower technology.

The standard specifies requirements for the design and construction of the mower with the emphasis on safety for the user and the bystander, while consistent with the permitting of satisfactory performance in the intended task of cutting and catching grass. Throughout the preparation of this edition particular consideration was given to the safety of the operator while in control of the mower, and for this purpose, suitable test methods are specified in order to limit the possibility of accidental contact with the blades and to control the dangerous ejection of objects from the mower. Tests for blades and their means of attachment are included to ensure that they are sufficiently robust to withstand all conditions which may occur in the normal use of a mower.

© Copyright — STANDARDS ASSOCIATION OF AUSTRALIA 1983

Users of standards are reminded that copyright subsists in all SAA publications. No part of this publication may be reproduced, stored in a retrieval system in any form or transmitted by any means without prior permission in writing of the Standards Association of Australia.

CONTENTS

| | <i>Page</i> |
|--|-------------|
| SECTION 1. SCOPE AND GENERAL | |
| 1.1 Scope | 4 |
| 1.2 Application | 4 |
| 1.3 Referenced Documents | 4 |
| 1.4 Definitions | 4 |
| 1.5 Electrical Safety Requirements | 4 |
| SECTION 2. CONSTRUCTIONAL REQUIREMENTS | |
| 2.1 Blades | 5 |
| 2.2 Blade Mountings | 5 |
| 2.3 Handle | 5 |
| 2.4 Cut-out Switch | 5 |
| 2.5 Power Controls | 5 |
| SECTION 3. TEST REQUIREMENTS | |
| 3.1 Accessibility | 6 |
| 3.2 Foot Probe Test | 6 |
| 3.3 Impact Test | 6 |
| 3.4 Unbalance Test | 6 |
| 3.5 Reverse Torque Test | 6 |
| 3.6 Structural Integrity Test | 6 |
| 3.7 Thrown Object Test | 6 |
| SECTION 4. SAFETY INSTRUCTIONS AND MARKING | |
| 4.1 Safety Instructions | 7 |
| 4.2 Marking | 7 |
| 4.3 Warning Notice | 7 |
| APPENDICES | |
| A Accessibility | 8 |
| B Foot Probe Test | 9 |
| C Preconditioning Procedure for Impact and Structural Integrity Type Tests | 12 |
| D Impact Test | 13 |
| E Unbalance Test | 15 |
| F Reverse Torque Test | 16 |
| G Structural Integrity Test | 17 |
| H Corrugated Fibreboard Penetration Test | 19 |
| J Thrown Object Test | 21 |
| K Safety Instructions | 24 |

STANDARDS ASSOCIATION OF AUSTRALIA

Australian Standard
for
POWERED ROTARY LAWNMOWERS

SECTION 1. SCOPE AND GENERAL

1.1 SCOPE. This standard specifies requirements for the construction and design of powered rotary lawnmowers, together with appropriate test methods for qualitatively assessing the robustness of the cutting means and their means of attachment.

The standard does not include performance requirements for lawnmowers other than those relating to safety.

1.2 APPLICATION. This standard applies to powered rotary lawnmowers of the walk-behind type intended essentially for domestic use.

It does not apply to powered cylinder type lawnmowers or powered lawnmowers of the ride-on type.

1.3 REFERENCED DOCUMENTS. The following documents are referred to in this standard:

- | | |
|---------|---|
| AS 1074 | Steel Tubes and Tubulars Threaded or Suitable for Threading with Pipe Threads of Whitworth Form |
| AS 3156 | Approval and Test Specification for Electric Lawnmowers |

1.4 DEFINITIONS. For the purpose of this standard the following definitions apply:

1.4.1 Powered rotary lawnmower—a mower incorporating one or more blade assemblies in which the cutting edge or edges are in a substantially horizontal plane and driven in rotation about a vertical axis at

such a speed that will, under normal operating conditions, cut grass.

NOTE: Throughout this standard the term 'mower' is to be taken to mean 'powered rotary lawnmower'.

1.4.2 Blade—the means by which grass is cut, including both metal and non-metal cutting means.

1.4.3 Blade tip circle—a circle described by the outermost point of a fully extended blade as it rotates about its vertical axis.

1.4.4 Swing-over handle—a handle which may be pivoted from one end of the mower to the other to permit reversing the direction of travel of the mower without turning the mower around.

1.4.5 Maximum speed—the maximum rotational speed of the blade assembly attained under no-load conditions using the controls provided for the operator.

1.4.6 Cutting area of the blades—the area of the blades which lies in the annulus between the blade tip circle and a concentric circle which has a diameter which is 80 percent of that of the blade tip circle (see Fig. 1).

1.5 ELECTRICAL SAFETY REQUIREMENTS. This standard does not include the electrical safety requirements which must be observed to secure approval for connection or sale of mowers. An electrically powered rotary lawnmower shall, in addition to complying with this standard, comply with the requirements of AS 3156.

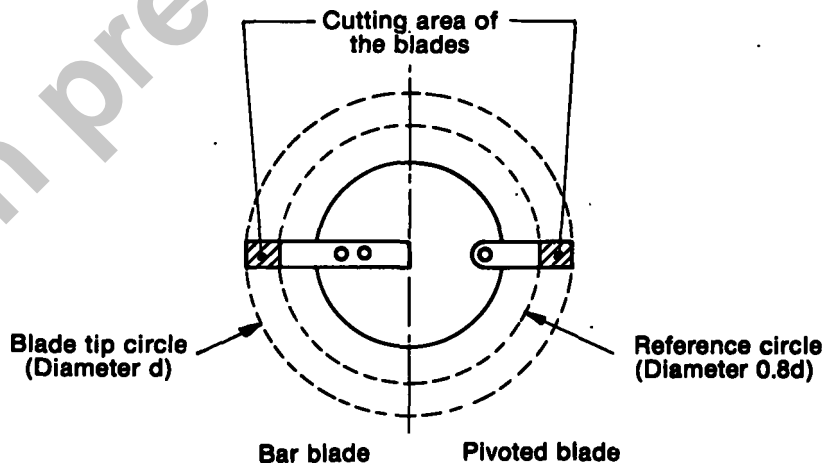

Fig. 1. CUTTING AREA OF THE BLADES