

Superseded by AS 2175-1995

Under Revision See DR 94177

AS 2175—1990

Australian Standard®

---

**Articulated vehicles — Kingpins**

---

F



**STANDARDS AUSTRALIA**



This Australian Standard was prepared by Committee ME/53, Semitrailer and Heavy Trailer Couplings. It was approved on behalf of the Council of Standards Australia on 2 February 1990 and published on 11 June 1990.

---

The following interests are represented on Committee ME/53:

Australian Road Research Board  
Australian Road Transport Federation  
Austroads  
Commercial Vehicle Industry Association of Australia  
Department of Defence  
Department of Transport and Communications  
Federal Chamber of Automotive Industries  
Institute of Metals and Materials Australasia  
Institute of Road Transport Engineers  
Society of Automotive Engineers—Australia  
Telecom Australia  
Vic Roads  
Victorian Road Transport Association

---

*Review of Australian Standards.* To keep abreast of progress in industry, Australian Standards are subject to periodic review and are kept up-to-date by the issue of amendments or new editions as necessary. It is important therefore that Standards users ensure that they are in possession of the latest edition, and amend themselves thereto.

*Further details of all Australian Standards and related publications will be found in the Standards Australia Catalogue of Publications; this information is supplemented each month by the magazine 'The Australian Standard', which subscribing members receive, and which gives details of new publications, new editions and amendments, and of withdrawn Standards.*

*Suggestions for improvements to Australian Standards, addressed to the head office of Standards Australia, are welcomed. Notification of any inaccuracy or ambiguity found in an Australian Standard should be made without delay in order that the matter may be investigated and appropriate action taken.*

---

Australian Standard®

---

**Articulated vehicles—Hingpins**

---

First published as AS D14—1968 and AS D15—1968.  
AS D14—1968 revised and redesignated AS 2175.1—1978.  
AS D15—1968 revised and redesignated AS 2175.2—1978.  
AS 2175.1—1978 and AS 2175.2—1978 revised, amalga-  
mated, and redesignated AS 2175—1988.

## PREFACE

This Standard was prepared by the Standards Australia Committee on Semitrailer and Heavy Trailer Couplings, to supersede AS 2175—1978, *Kingpins for semitrailers and lowloaders, Part 1: 50 mm kingpin for semitrailers and lowloaders*, and Part 2: *90 mm kingpin for semitrailers and lowloaders*.

The method of rating and selecting kingpins in this Standard is based on the 'D-value' method used in the United Nations ECE Regulation 55\*, and in ISO and DIN Standards.

In this Standard, the D-value has been specified in kilonewtons to avoid confusion with the towed-load capacity of the coupling. This unit is also being used more widely in Europe.

In the application of the D-value method, a series of equations is used to determine the rated strength required. In this Standard, these equations have been obtained from original experimental research conducted by the Australian Road Research Board. These equations differ from those used in the ECE Regulation 55 and the ISO and DIN Standards in order to reflect Australian conditions. Where the equation for semitrailers, i.e. for articulated vehicles with one trailer is the same as in ECE, ISO, and DIN documents, additional equations have been developed for multiple trailer combinations in accordance with Australian practice.

Because the geometry of the kingpin is closely defined, its design strength can also be determined by material specification. Therefore, an optional rating procedure by material specifications has been incorporated in the Standard. It was felt by the committee that existing designs of kingpins in Australia which have not been D-value rated but which have shown satisfactory performance should continue to be acceptable if stringent material requirements are complied with. These material specifications are based on existing practice and experience in Australia and will ensure adequate strength and performance of these kingpins for normal applications. However, kingpins used in B-double and road-train applications should be D-value rated to ensure sufficient strength. Appendix B to this Standard gives guidelines on the selection of D-rated kingpins for various applications.

This Standard correlates with the dimensional requirements in International Standards for 50 mm kingpins (ISO 337†) with one minor deviation, and for 90 mm kingpins (ISO 4086‡) without deviation. Whereas ISO 337† specifies M14 bolts for 50 mm flange bolt kingpins, a bolt size of M16 has been chosen, as M14 is a non-preferred size and not readily available in Australia in the particular grade.

Guidelines for the attachment of kingpin to skid plate are given in Appendix D, and include a method for evaluating the strength of attachment based upon a test method specified in SAE J133§ but using a statically applied load.

\* ECE R55 United Nations agreement concerning the adoption of uniform conditions of approval and reciprocal recognition of approval for motor vehicles equipment and parts, done at Geneva, 20 March 1958; Addendum 54, Regulation 55.

† ISO 337 Road Vehicles—50 mm semi-trailer fifth wheel coupling pin—Basic and mounting/interchangeability dimensions.

‡ ISO 4086 Road Vehicles—90 mm semi-trailer fifth wheel coupling pin—Basic and mounting/interchangeability dimensions.

§ SAE J133 Fifth wheel kingpin performance—commercial trailers and semitrailers. (SAE recommended practice.)

### © Copyright — STANDARDS AUSTRALIA

Purchasers of Standards are reminded that copyright subsists in all Standards Australia publications and software. Except where the Copyright Act allows and except where provided for below no publications or software produced by Standards Australia may be reproduced, stored in a retrieval system in any form or transmitted by any means without prior permission in writing from Standards Australia. Permission may be conditional on an appropriate royalty payment. Requests for permission and information on commercial software royalties should be directed to the Head Office of Standards Australia.

Standards Australia will permit up to 10 percent of the technical content pages of a Standard to be copied for use exclusively in-house by purchasers of the Standard without payment of a royalty or advice to Standards Australia.

Standards Australia will also permit the inclusion of its copyright material in computer software programs for no royalty payment provided such programs are used exclusively in-house by the creators of the programs.

Care should be taken to ensure that material used is from the current edition of the Standard and that it is updated whenever the Standard is amended or revised. The number and date of the Standard should therefore be clearly identified.

The use of material in print form or in computer software programs to be used commercially, with or without payment, or in commercial contracts is subject to the payment of a royalty. This policy may be varied by Standards Australia at any time.

## CONTENTS

	<i>Page</i>
<b>SECTION 1 SCOPE AND GENERAL</b>	
1.1 SCOPE .....	4
1.2 REFERENCED DOCUMENTS .....	4
1.3 DEFINITIONS .....	5
1.4 MARKING .....	5
<b>SECTION 2 RATING</b>	
2.1 GENERAL .....	6
2.2 RATING BY D-VALUE (D-RATED KINGPINS) .....	7
2.3 RATING BY MECHANICAL PROPERTIES (M-RATED KINGPINS) .....	7
<b>SECTION 3 MATERIALS OF WELDABLE KINGPINS</b>	
3.1 GENERAL .....	8
3.2 CALCULATION OF CARBON EQUIVALENT .....	8
<b>SECTION 4 DIMENSIONAL REQUIREMENTS</b>	
4.1 GENERAL .....	9
4.2 BOLT-IN KINGPINS .....	9
4.3 WELD-IN KINGPINS .....	9
<b>APPENDICES</b>	
A DYNAMIC TEST METHOD .....	14
B SELECTION OF D-RATED KINGPINS .....	15
C RECOMMENDED WEAR LIMITS .....	18
D GUIDELINES FOR THE ATTACHMENT OF KINGPIN TO SKID PLATE .....	19

## STANDARDS AUSTRALIA

**Australian Standard**  
**Articulated vehicles—Kingpins**

## SECTION 1 SCOPE AND GENERAL

**1.1 SCOPE.** This Standard specifies requirements for 50 mm and 90 mm kingpins for semitrailers used in articulated vehicles, B-doubles, and road trains, in normal use on both sealed and unsealed roads.

The requirements cover mechanical properties, dimensional standards for interchangeability, strength testing, and rating.

## NOTES:

1. Recommendations and requirements for fifth wheel assemblies on prime movers are given in AS 1773 and AS 1773.
2. Guidance on the selection of kingpins is given in Appendix B.
3. Recommended wear limits are given in Appendix C.
4. Guidance on the attachment of kingpins is given in Appendix D.

**1.2 REFERENCED DOCUMENTS.** The following documents are referred to in this Standard:

## AS

- 1110 ISO metric hexagon precision bolts and screws  
 1171 Methods for magnetic particle testing of ferromagnetic products and components  
 1391 Methods for tensile testing of metals  
 1444 Wrought alloy steels—Standard and hardenability (1) series  
 1771 Installation of fifth wheel and turntable assemblies  
 1773 Articulated vehicles—Fifth wheel assemblies  
 1815 Method for Rockwell hardness test  
 1815.1 Part 1: Testing of metals  
 2536 Surface texture

## ISO

- 337 Road vehicles—50 semi-trailer fifth wheel coupling pin—Basic and mounting/interchangeability dimensions

## ECE

- R55 United Nations agreement concerning the adoption of uniform conditions of approval and reciprocal recognition of approval for motor vehicles equipment and parts, done at Geneva, 20 March 1958; Annexum 54, Regulation 55.

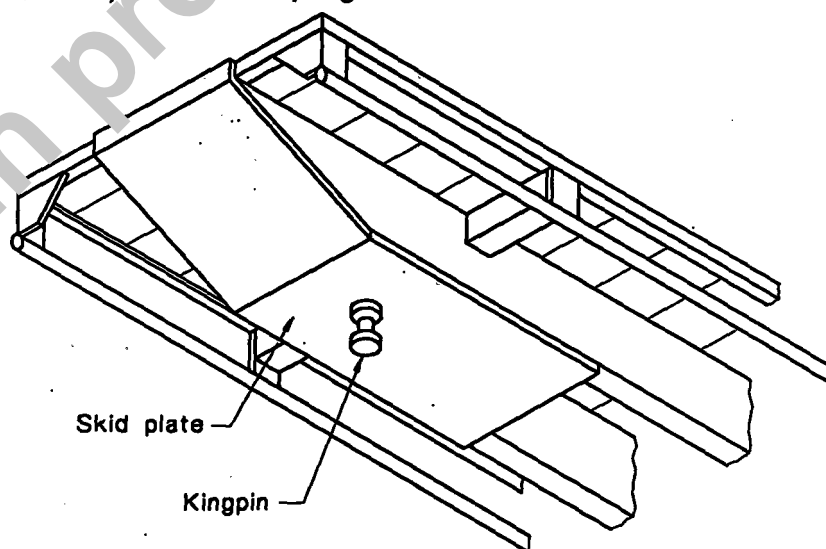

FIGURE 1.1 TYPICAL KINGPIN AND SKID PLATE