

Amendment 1 - April 1990.

Dup

Superseded by AS 1299-1993

AS 1299—1989

Australian Standard®

**Electrical equipment for coal
mines—Flameproof restrained plugs
and receptacles**

Currently in preview, click to buy full version

E



This Australian Standard was prepared by Committee EL/23, Electrical Equipment in Coal Mines. It was approved on behalf of the Council of Standards Australia on 3 December 1987 and published on 14 July 1989.

The following interests are represented on Committee EL/23:

Australian Coal Association
Australian Electrical and Electronic Manufacturers Association
Confederation of Australian Industry
Department of Minerals and Energy, N.S.W.
Department of Mines, Qld
Joint Coal Board
Institution of Mining Electrical and Mining Mechanical Engineers
Regulatory authorities (electrical)

Review of Australian Standards. To keep abreast of progress in industry, Australian Standards are subject to periodic review and are kept up-to-date by the issue of amendments or new editions as necessary. It is important therefore that Standards users ensure that they are in possession of the latest edition, and any amendments thereto.

Full details of Australian Standards and related publications will be found in the Standards Australia Catalogue of Publications; this information is supplemented each month by the magazine 'The Australian Standard' which subscribing members receive, and which gives details of new publications, new editions and amendments, and of withdrawn Standards.

Suggestions for improvements to Australian Standards, addressed to the head office of Standards Australia, are welcomed. Notification of any inaccuracy or ambiguity found in an Australian Standard should be made without delay in order that the matter may be investigated and appropriate action taken.

STANDARDS AUSTRALIA

Amendment No 1

to

AS 1299—1989

Electrical equipment for coal mines—
Flameproof restrained plugs and receptacles

REVISED TEXT

The 1989 edition of AS 1299 is amended as follows; the amendment(s) should be inserted in the appropriate place.

SUMMARY: This Amendment applies to Table 1.1, Table 2.1, Table 3.1, Clause 3.3.7.2, Clause 3.3.7.3, Table 3.3, Figure 1.13 and Figure 1.14

Published on 2 April 1990.

AMDT
No 1
APRIL
1990

Page 5. Table 1.1.

Add the following:

Voltage	Maximum current A	Colour code to AS 2700	For dimensions refer to
660 V	425	X15/N24	Figure 1.13
1100 V	425	B24/N24	Figure 1.14

AMDT
No 1
APRIL
1990

Page 17. Table 2.1.

Add the following:

Rating A	Main core		Pilot core	
	Diameter	Insertion depth	Diameter	Insertion depth
425	23	25	7	10

AMDT
No 1
APRIL
1990

Page 19. Table 3.1.

Add the following:

Current rating A	Axial force, newtons	
	To insert	To withdraw
425	≤ 150	≥ 60

AMDT
No 1
APRIL
1990

Page 20. Clause 3.3.7.2.

Add the following:

Current rating A	Cross-sectional area mm ²
425	185

AMDT
No 1
APRIL
1990

Page 20. Clause 3.3.7.3.

Add the following:

Current rating A	Cross-sectional area mm ²
425	185

AMDT
No 1
APRIL
1990

Page 21. Table 3.3.

Add the following:

Current rating, A	Test current, kA		Asymmetrical peak factor	Power factor
	Rated voltage			
	660/1.1 kV	3.3 kV		
425	25		2.0	0.3

Add Figures 1.13 and 1.14.

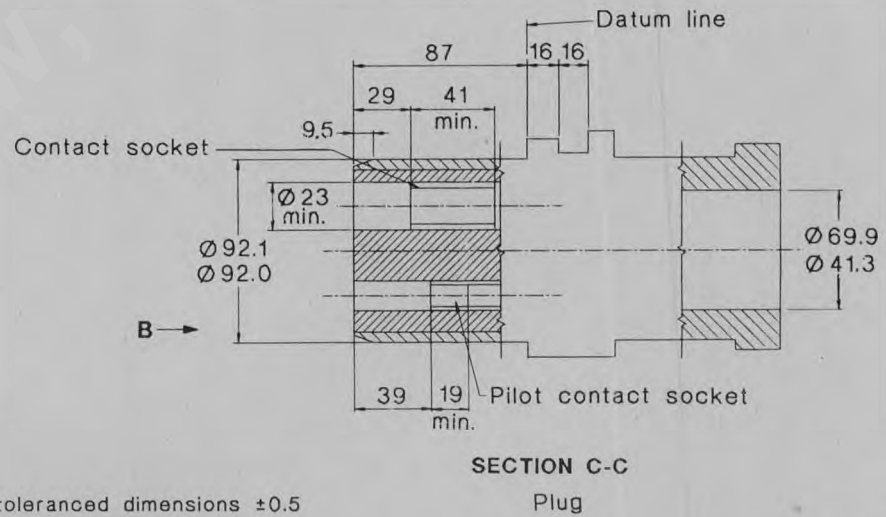
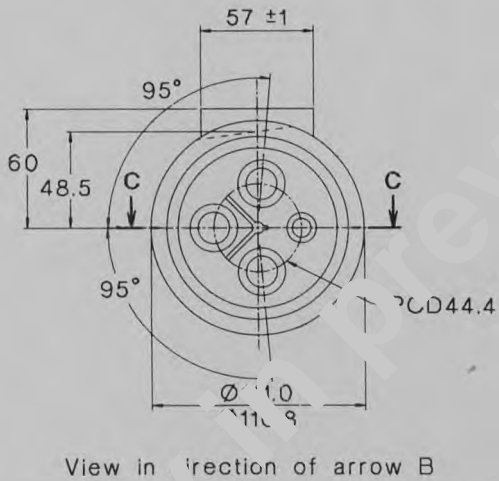
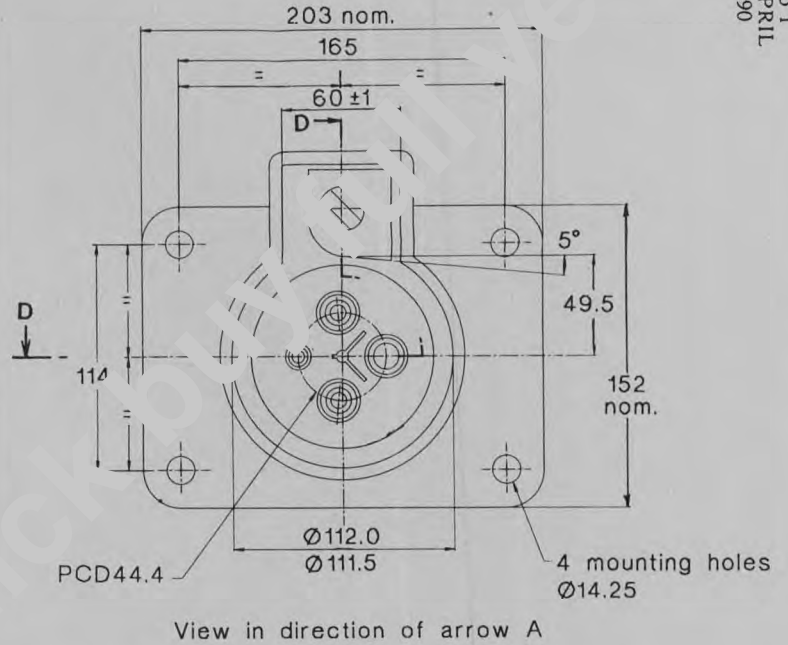
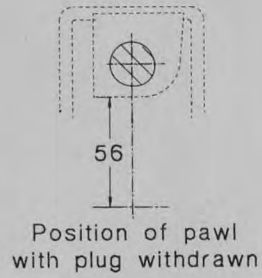
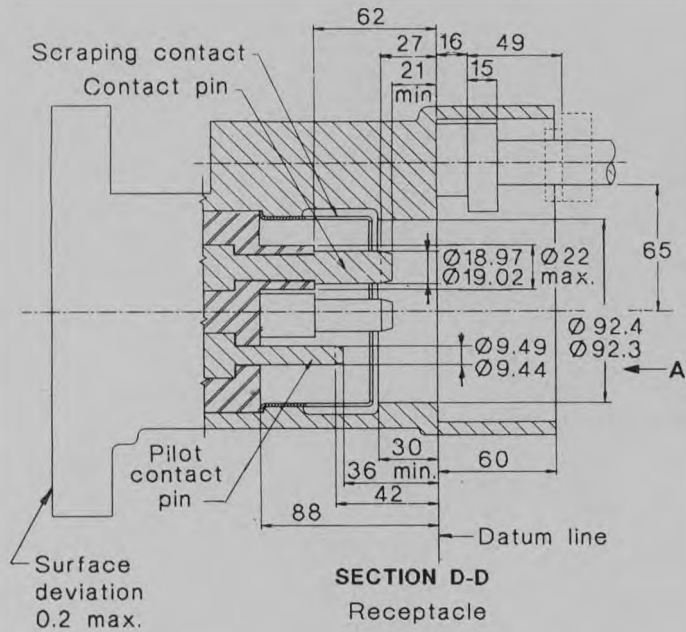

Untoleranced dimensions ± 0.5
NOT TO SCALE
DIMENSIONS IN MILLIMETRES

FIGURE 1.13 PLUG AND RECEPTACLE, 660 V, 425 A

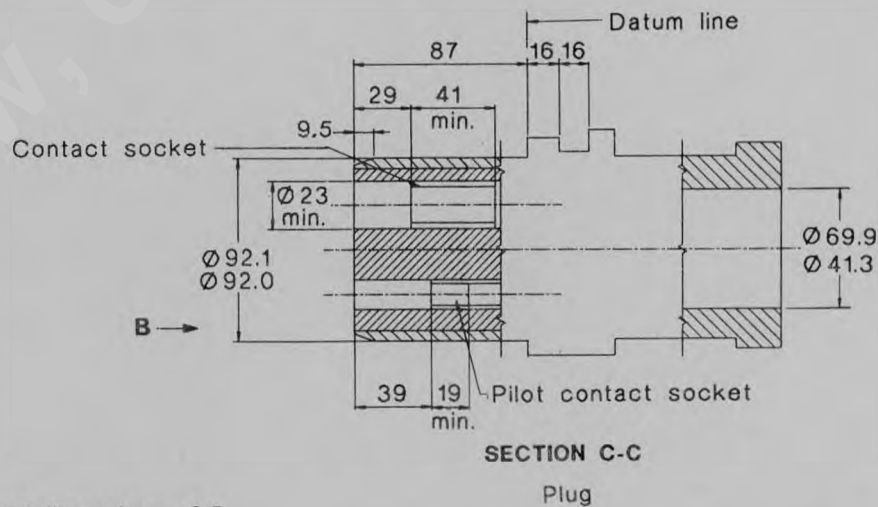
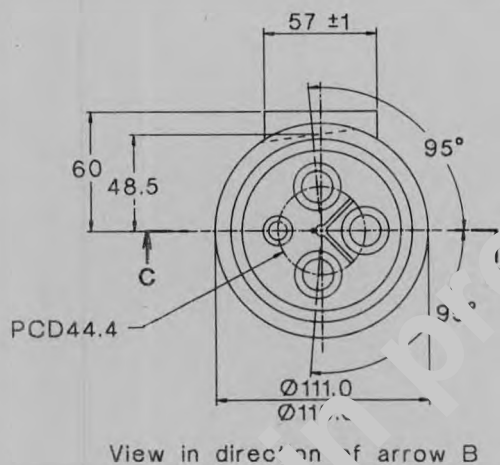
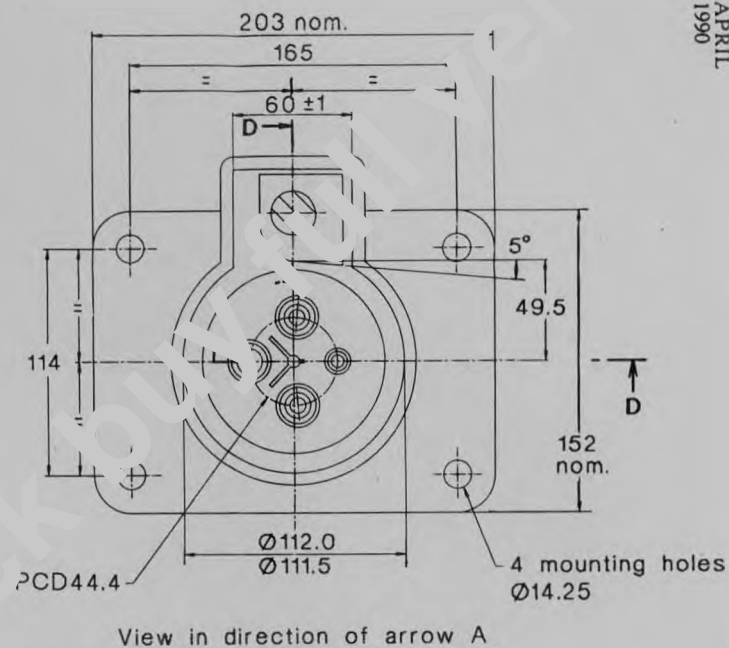
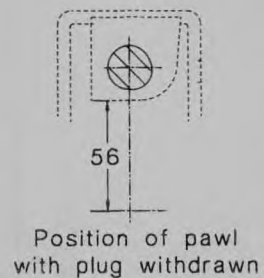
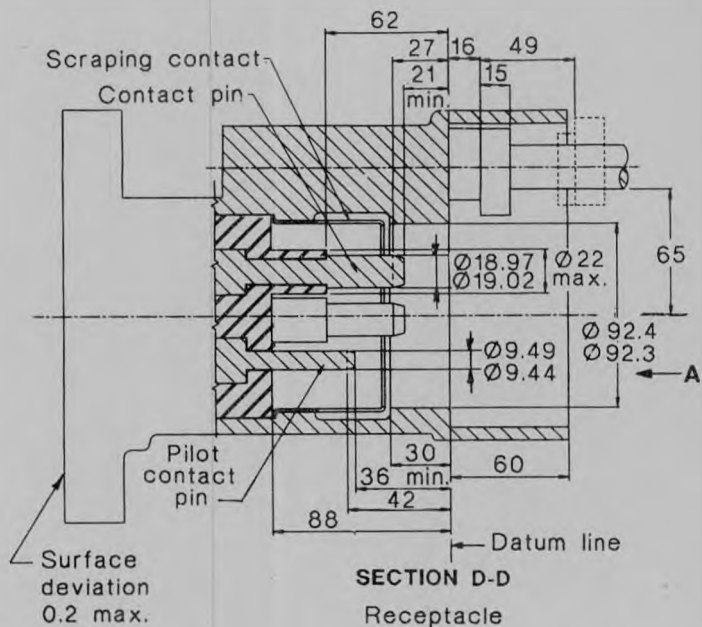

Untoleranced dimensions ± 0.5
NOT TO SCALE
DIMENSIONS IN MILLIMETRES

FIGURE 1.14 PLUG AND RECEPTACLE, 1.1 kV, 425 A

Australian Standard®

**Electrical equipment for coal
mines—Flameproof restrained plugs
and receptacles**

First published as AS 1299—1973.
Second edition 1981.
Third edition 1984.
Fourth edition 1989.

PUBLISHED BY STANDARDS AUSTRALIA
(STANDARDS ASSOCIATION OF AUSTRALIA)
STANDARDS HOUSE, 80 ARTHUR ST, NORTH SYDNEY NSW

ISBN 0 7262 4837 1

PREFACE

This Standard was prepared by Standards Australia's Committee on Electrical Equipment in Coal Mines and supersedes AS 1299—1984. It is intended for the guidance of manufacturers, users, regulatory authorities and associated interests and for use with Australian Standards and relevant mining regulations.

Major changes are as follows:

- (a) Provision for 3.3 kV rated plugs necessitating changes in appropriate tables, drawings and clauses.
- (b) Changes to material tensile strength requirements of Clause 2.3 from 220 MPa to 450 MPa.
- (c) Removal of minimum terminal crimping pressure requirement in Clause 2.6.1.
- (d) Altered requirement for the PHASE BARRIER in Clause 2.9.
- (e) Revision of the requirements of Clause 3.2.4, Insulation test.
- (f) Incorporation of the 'cable gland (slip load) test' procedure into Clause 3.3, Type tests.
- (g) Alterations to the time and voltage requirements of Clause 3.3.6, High voltage test.
- (h) Stipulation of maximum ambient temperature for the temperature rise test in Clause 3.3.7.1.
- (i) Incorporation of a table for TEST CURRENT in Clause 3.3.9, Short-circuit (through-fault) test.
- (j) The plug and receptacle diagrams (Figures 1.3 to 1.12) are listed in the order given in Table 1.1 (by voltage).

© Copyright — STANDARDS AUSTRALIA

Users of Standards are reminded that copyright subsists in all Standards Australia publications and software. Except where the Copyright Act allows and except where provided for below no publications or software produced by Standards Australia may be reproduced, stored in a retrieval system in any form or transmitted by any means without prior permission in writing from Standards Australia. Permission may be conditional on an appropriate royalty payment. Requests for permission and information on commercial software royalties should be directed to the Head Office of Standards Australia.

Standards Australia will permit up to 10 percent of the technical content pages of a Standard to be copied for use exclusively in-house by purchasers of the Standard without payment of a royalty or advice to Standards Australia.

Standards Australia will also permit the inclusion of its copyright material in computer software programs for no royalty payment provided such programs are used exclusively in-house by the creators of the programs.

Care should be taken to ensure that material used is from the current edition of the Standard and that it is updated whenever the Standard is amended or revised. The number and date of the Standard should therefore be clearly identified.

The use of material in print form or in computer software programs to be used commercially, with or without payment, or in commercial contracts is subject to the payment of a royalty. This policy may be varied by Standards Australia at any time.

CONTENTS

	<i>Page</i>
SECTION 1. SCOPE AND GENERAL	
1.1 SCOPE	4
1.2 REFERENCED DOCUMENTS	4
1.3 DEFINITIONS	4
1.4 SERVICE CONDITIONS	5
1.5 RATINGS, DIMENSIONS AND COLOUR CODING	5
1.6 MARKING	5
SECTION 2. DESIGN AND CONSTRUCTION	
2.1 FLAMEPROOF ENCLOSURE	17
2.2 CLEARANCE AND CREEPAGE	17
2.3 MATERIALS	17
2.4 FASTENERS	17
2.5 CABLE GLANDS	17
2.6 TERMINALS	17
2.7 CONTACT SOCKETS AND PINS	17
2.8 EARTHING	17
2.9 PHASE BARRIER	18
2.10 INSULATION	18
2.11 OPERATING AND RETAINING DEVICE	18
2.12 CABLE REEL RECEPTACLE	18
SECTION 3. TESTING	
3.1 CATEGORIES OF TESTS	19
3.2 ROUTINE TESTS	19
3.3 TYPE TESTS	19
APPENDIX A. INFORMATION TO BE PROVIDED WITH ENQUIRY AND ORDER	22

STANDARDS AUSTRALIA

Australian Standard

Electrical equipment for coal mines—Flameproof restrained plugs and receptacles

SECTION 1. SCOPE AND GENERAL

1.1 SCOPE. This Standard specifies the dimensional and test requirements for flameproof restrained plugs and receptacles, incorporating three power contacts, one auxiliary contact, a scraping earth contact and an earthed phase barrier, intended for use with restricted earth-fault systems in coal mines. Provision is also made for plug coupling units which enable lengths of trailing cable to be coupled together. Restrained plugs and receptacles to this Standard are not intended to be coupled or uncoupled while the circuit is energized.

The Standard prescribes the dimensions necessary to provide for the interconnection of restrained plugs and receptacles of different makes; it also deals with some electrical and mechanical requirements including the provision of earthed phase barriers for protection against interphase faults. It does not, however, purport to otherwise specify a fully detailed design.

The Standard provides for plug and receptacle discrimination, i.e. an arrangement whereby fitting of plugs and receptacles of different rated voltages is physically prevented from engagement.

NOTES:

1. The term 'receptacle' as used in this Standard is synonymous with the term 'socket-outlet' in AS 3000. The term 'receptacle' has been chosen to avoid confusion with the individual sockets within the plug.
2. Appendix A lists information which should be supplied by user with any inquiry or order.
3. A typical plug and receptacle assembly is shown in Figure 1.1 and a typical plug coupling unit is shown in Figure 1.2.

1.2 REFERENCED DOCUMENTS. The documents below are referred to in this Standard.

AS	
1147	Plastics insulating materials and mouldings for cable connecting devices for use in coal mines
1802	Reeling and trailing electric cables for underground coal mining purposes
1828	Electrical equipment for explosive atmospheres—Cable glands
1856	Electroplated coatings of silver for engineering applications
1972	Cables for use below ground in coal mines (Other than trailing cables)
2380	Electrical equipment for explosive atmospheres—Explosion protection techniques
2700	Part 6: Increased safety
2780	Electrical equipment for explosive atmospheres—Flameproof enclosure—Type of protection d
2700	Colour standards for general purposes
3000	SAA Wiring Rules
3147	Approval and test specification—Electric cables—Thermoplastic insulated for working voltages up to and including 0.6/1 kV

1.3 DEFINITIONS. For the purpose of this Standard the definitions below apply.

1.3.1 Approved—approved by a Regulatory Authority.

1.3.2 Cable gland—device to secure the end of a cable, by means appropriate to the type of cable, and may include provision for making earthing connections.

1.3.3 Contact pin—rigid conducting member for electrical power circuits intended to be inserted in a main contact socket of suitable form so as to make electrical contact.

1.3.4 Contact socket—resilient conducting member for electrical power circuits intended to receive a suitable main contact pin so as to make electrical contact.

1.3.5 Cable reel receptacle, left hand—one that is fitted to a standard drive shuttle car. (See Figure 1.5.)

1.3.6 Cable reel receptacle, right hand—one that is fitted to an opposite standard drive shuttle car. (See Figure 1.5.)

1.3.7 Phase barrier—metallic barrier which is electrically connected to earth, and is situated in the contact insulation in both the restrained plug and receptacle for the purpose of preventing an interphase fault within the unit.

1.3.8 Pilot contact pin—rigid conducting member for other than electrical power circuits intended to be inserted in a pilot contact socket of suitable form so as to make electrical contact.

1.3.9 Pilot contact socket—resilient conducting member for other than electrical power circuits intended to receive a suitable pilot contact pin.

1.3.10 Plug—that portion of a restrained plug and receptacle having contacts consisting of sockets and which is attached to a trailing cable and is designed for engagement within the receptacle.

1.3.11 Receptacle—that portion of a restrained plug and receptacle having contacts consisting of pins and which is designed to receive the plug.

1.3.12 Regulatory Authority—relevant authority responsible for the implementation of Government regulations applying to coal mines in each of the States and Territories of Australia.

1.3.13 Restrained cable reel plug and receptacle—special form of restrained plug and receptacle shaped to suit a right-angled entry into, and the periphery of, a cable reel drum.