

Specification for Bonded Flexible Pipe

ANSI/API SPECIFICATION 17K
SECOND EDITION, NOVEMBER 2005

EFFECTIVE DATE: MAY 1, 2006

REAFFIRMED, MAY 2010
REAFFIRMED, SEPTEMBER 2016

ISO 13628-10 (Identical), Petroleum and natural gas industries—Design and operation of subsea production systems—Part 10: Specification for bonded flexible pipe



AMERICAN PETROLEUM INSTITUTE



Currently in preview, click buy full version

Special Notes

API publications necessarily address problems of a general nature. With respect to particular circumstances, local, state, and federal laws and regulations should be reviewed.

Neither API nor any of API's employees, subcontractors, consultants, committees, or other assignees make any warranty or representation, either express or implied, with respect to the accuracy, completeness, or usefulness of the information contained herein, or assume any liability or responsibility for any use, or the results of such use, of any information or process disclosed in this publication. Neither API nor any of API's employees, subcontractors, consultants, or other assignees represent that use of this publication would not infringe upon privately owned rights.

API publications may be used by anyone desiring to do so. Every effort has been made by the Institute to assure the accuracy and reliability of the data contained in them; however, the Institute makes no representation, warranty, or guarantee in connection with this publication and hereby expressly disclaims any liability or responsibility for loss or damage resulting from its use or for the violation of any authorities having jurisdiction with which this publication may conflict.

API publications are published to facilitate the broad availability of proven sound engineering and operating practices. These publications are not intended to obviate the need for applying sound engineering judgment regarding when and where these publications should be utilized. The formulation and publication of API publications is not intended in any way to inhibit anyone from using any other practices.

Any manufacturer marking equipment or materials in conformance with the marking requirements of an API standard is solely responsible for complying with all the applicable requirements of that standard. API does not represent, warrant, or guarantee that such products do in fact conform to the applicable API standard.

Users of this Specification should not rely exclusively on the information contained in this document. Sound business, scientific, engineering, and safety judgment should be used in employing the information contained herein

All rights reserved. No part of this work may be reproduced, stored in a retrieval system, or transmitted by any means, electronic, mechanical, photocopying, recording, or otherwise, without prior written permission from the publisher. Contact the Publisher, API Publishing Services, 1220 L Street, N.W., Washington, D.C. 20005.

Copyright © 2005 American Petroleum Institute

API Foreword

Nothing contained in any API publication is to be construed as granting any right, by implication or otherwise, for the manufacture, sale, or use of any method, apparatus, or product covered by letters patent. Neither should anything contained in the publication be construed as insuring anyone against liability for infringement of letters patent.

This document was produced under API standardization procedures that ensure appropriate notification and participation in the developmental process and is designated as an API standard. Questions concerning the interpretation of the content of this publication or comments and questions concerning the procedures under which this publication was developed should be directed in writing to the Director of Standards, American Petroleum Institute, 1220 L Street, N.W., Washington, D.C. 20005. Requests for permission to reproduce or translate all or any part of the material published herein should also be addressed to the director.

Generally, API standards are reviewed and revised, reaffirmed, or withdrawn at least every five years. A one-time extension of up to two years may be added to this review cycle. Status of the publication can be ascertained from the API Standards Department, telephone (202) 682-8000. A catalog of API publications and materials is published annually and updated quarterly by API, 1220 L Street, N.W., Washington, D.C. 20005.

This standard shall become effective on the date printed on the cover but may be used voluntarily from the date of distribution.

Standards referenced herein may be replaced by other international or national standards that can be shown to meet or exceed the requirements of the referenced standard. Manufacturers electing to use another standard in lieu of a referenced standard are responsible for documenting equivalency.

Additional information for users of API Specification 17K is found in Annex D.

This American National Standard is under the jurisdiction of the API Subcommittee 17. This standard is considered identical to the English version of ISO 13628-10:2005. ISO 13628-10:2005 was prepared by Technical Committee ISO/TC 67, Materials, equipment and offshore structures for petroleum, petrochemical and natural gas industries, SC 4, Drilling and production equipment.

Suggested revisions are invited and should be submitted to the Standards and Publications Department, API, 1220 L Street, NW, Washington, D.C. 20005, standards@api.org.

Contents

	Page
API Foreword	ii
Foreword	v
Introduction	vi
1 Scope	1
1.1 Purpose	1
1.2 Products	2
1.3 Applications	2
2 Normative references	2
3 Terms, definitions and abbreviations	5
3.1 Terms and definitions	5
3.2 Symbols and abbreviations	10
4 Functional requirements	11
4.1 General	11
4.2 Overall requirements	11
4.3 General design parameters	12
4.4 Internal fluid parameters	12
4.5 External environment	14
4.6 System requirements	14
5 Design requirements	17
5.1 Loads and load effects	17
5.2 Pipe design methodology	20
5.3 Pipe structure design	21
5.4 System design requirements	26
6 Materials	29
6.1 Material requirements	29
6.2 Qualification requirements	33
6.3 Quality assurance requirements	39
7 Manufacturing requirements	41
7.1 Quality assurance requirements	41
7.2 Carcass	42
7.3 Preparation of compound and calendaring	43
7.4 Elastomer winding	44
7.5 Reinforcement and rou layer	45
7.6 Insulation layers	45
7.7 End fitting	45
7.8 Curing processes	47
7.9 Special processes	48
7.10 Manufacturing tolerances	50
7.11 Repair	50
8 Documentation	51
8.1 General	51
8.2 Design premise	51
8.3 Design load report	51
8.4 Design report	51
8.5 Manufacturing quality plan	52
8.6 Fabrication specification	52
8.7 As-built documentation	52
8.8 Operation manual	53

9	Factory acceptance tests	54
9.1	General	54
9.2	Gauge test	55
9.3	Hydrostatic pressure test	55
9.4	Electrical continuity and resistance tests	56
9.5	Kerosene test	56
9.6	Vacuum test	56
10	Marking and packaging	57
10.1	Marking	57
10.2	Packaging	57
Annex A	(informative) Purchasing guidelines	59
Annex B	(informative) Bend stiffeners and bend restrictors	66
Annex C	(informative) Use of the API Monogram	71
Annex D	(informative) Additional API Specification 17K information	72
	Bibliography	73

Currently in preview, click buy full version

Foreword

ISO (the International Organization for Standardization) is a worldwide federation of national standards bodies (ISO member bodies). The work of preparing International Standards is normally carried out through ISO technical committees. Each member body interested in a subject for which a technical committee has been established has the right to be represented on that committee. International organizations, governmental and non-governmental, in liaison with ISO, also take part in the work. ISO collaborates closely with the International Electrotechnical Commission (IEC) on all matters of electrotechnical standardization.

International Standards are drafted in accordance with the rules given in the ISO/IEC Directive – Part 2.

The main task of technical committees is to prepare International Standards. Draft International Standards adopted by the technical committees are circulated to the member bodies for voting. Publication as an International Standard requires approval by at least 75 % of the member bodies casting a vote.

Attention is drawn to the possibility that some of the elements of this document may be the subject of patent rights. ISO shall not be held responsible for identifying any or all such patent rights.

ISO 13628-10 was prepared by Technical Committee ISO/TC 67, *Materials, equipment and offshore structures for petroleum, petrochemical and natural gas industries*, Subcommittee SC 4, *Drilling and production equipment*.

ISO 13628 consists of the following parts, under the general title *Petroleum and natural gas industries — Design and operation of subsea production systems*:

- *Part 1: General requirements and recommendations*
- *Part 2: Unbonded flexible pipe systems for subsea and marine applications*
- *Part 3: Through flowline (TFL) systems*
- *Part 4: Subsea wellhead and tree equipment*
- *Part 5: Subsea umbilical*
- *Part 6: Subsea production control systems*
- *Part 7: Completion/workover riser systems*
- *Part 8: Remotely Operated Vehicle (ROV) interfaces on subsea production systems*
- *Part 9: Remotely Operated Tool (ROT) intervention system*
- *Part 10: Specification for bonded flexible pipe*
- *Part 11: Flexible pipe systems for subsea and marine riser applications*

The following part is under preparation:

- *Part 12: Dynamic production risers*

Introduction

This part of ISO 13628 has been based on API Spec 17K, First Edition, September 2001.

Users of this International Standard should be aware that further or differing requirements might be needed for individual applications. This International Standard is not intended to inhibit a vendor from offering, or the purchaser from accepting, alternative equipment or engineering solutions for the individual application. This may be particularly applicable where there is innovative or developing technology. Where an alternative is offered, the vendor should identify any variations from this International Standard and provide details.

Currently in preview, click buy full version

Petroleum and natural gas industries — Design and operation of subsea production systems —

Part 10: Specification for bonded flexible pipe

1 Scope

1.1 Purpose

1.1.1 This part of ISO 13628 defines the technical requirements for safe, dimensionally and functionally interchangeable bonded flexible pipes that are designed and manufactured to uniform standards and criteria. See Figure 1 for explanatory figure on typical bonded flexible pipe.

1.1.2 Minimum requirements are specified for the design, material selection, manufacture, testing, marking and packaging of bonded flexible pipes, with reference to existing codes and standards where applicable. See API RP 17B for guidelines on the use of flexible pipes and ancillary components.

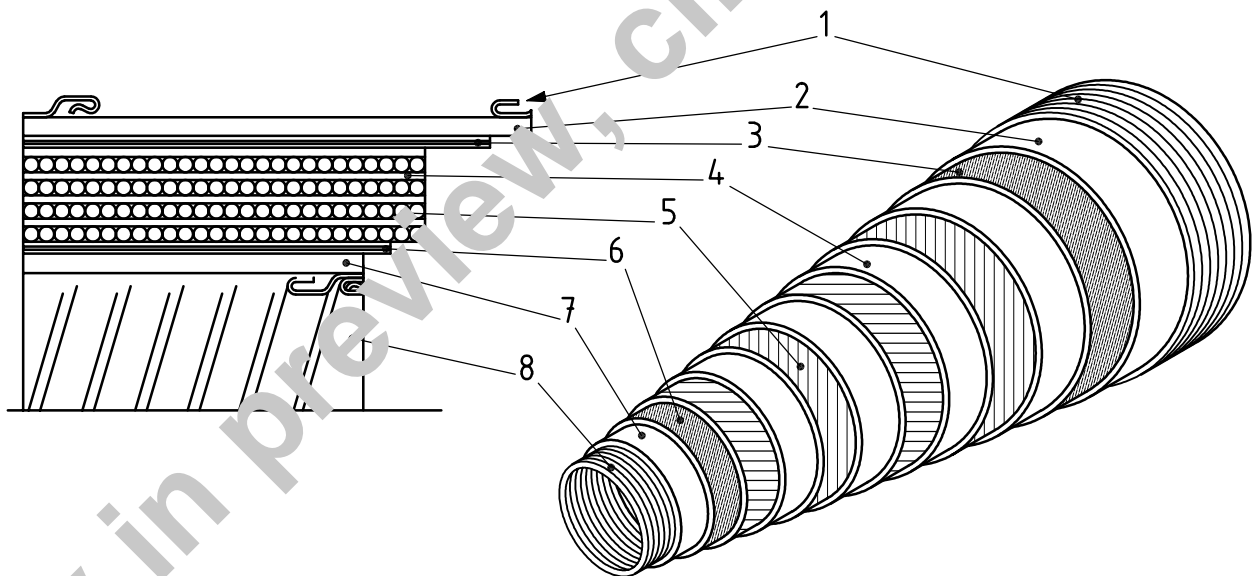

Key

- 1 outer wrap
- 2 cover
- 3 breaker layer
- 4 cushion layer

- 5 reinforcement layer
- 6 breaker layer
- 7 liner
- 8 carcass

Figure 1 — Typical bonded flexible pipe