



ANSI C136.58-2019

American National
Standard for Roadway
and Area Lighting
Equipment— Luminaire
Four-Pin Extension
Module and Receptacle
— Physical and
Electrical
Interchangeability and
Testing

National Electrical Manufacturers Association



National Electrical Manufacturers Association
1300 North 17th Street, Suite 900 • Rosslyn, VA 22209
www.NEMA.org

Currently in preview, click buy full version





ANSI C136.58-2019

*American National Standard for
Roadway and Area Lighting Equipment—
Luminaire Four-Pin Extension Module and Receptacle—
Physical and Electrical Interchangeability and Testing*

Secretariat:

National Electrical Manufacturers Association

Approved: August 8, 2019

American National Standards Institute, Inc.

NOTICE AND DISCLAIMER

The information in this publication was considered technically sound by a consensus among persons engaged in its development at the time it was approved. Consensus does not necessarily mean there was unanimous agreement among every person participating in the development process.

The National Electrical Manufacturers Association (NEMA) Standards and guideline publications, of which the document herein is one, are developed through a voluntary Standards development process. This process brings together volunteers and/or seeks out the views of persons who have an interest in the topic covered by this publication. Although NEMA administers the process and establishes rules to promote fairness in the development of consensus, it does not write the documents, nor does it independently test, evaluate, or verify the accuracy or completeness of any information or the soundness of any judgments contained in its Standards and guideline publications.

NEMA disclaims liability for any personal injury, property, or other damages of any nature, whether special, indirect, consequential, or compensatory, directly or indirectly resulting from the publication, use of, application, or reliance on this document. NEMA disclaims and makes no guaranty or warranty, express or implied, as to the accuracy or completeness of any information published herein, and disclaims and makes no warranty that the information in this document will fulfill any particular purpose(s) or need(s). NEMA does not undertake to guarantee the performance of any individual manufacturer's or seller's products or services by virtue of this Standard or guide.

In publishing and making this document available, NEMA is not undertaking to render professional or other services for or on behalf of any person or entity, nor is NEMA undertaking to perform any duty owed by any person or entity to someone else. Anyone using this document should rely on his or her own independent judgment or, as appropriate, seek the advice of a competent professional in determining the exercise of reasonable care in any given circumstance. Information and other Standards on the topic covered by this publication may be available from other sources, which the user may wish to consult for additional views or information not covered by this publication.

NEMA has no power, nor does it undertake to police or enforce compliance with the contents of this document. NEMA does not certify, test, or inspect products, designs, or installations for safety or health purposes. Any certification or other statement of compliance with any health- or safety-related information in this document shall not be attributable to NEMA and is solely the responsibility of the certifier or maker of the statement.

AMERICAN NATIONAL STANDARD

Approval of an American National Standard requires verification by ANSI. ANSI states that the requirements for due process, consensus, and other criteria for approval have been met by the Standards developer.

Consensus is established when, in the judgment of the ANSI Board of Standards Review, substantial agreement has been reached by directly and materially affected interests. Substantial agreement means significantly more than a simple majority, but not necessarily unanimity. Consensus requires that all views and objections be considered, and a concerted effort be made toward their resolution.

The use of American National Standards is completely voluntary; their existence does not in any respect preclude anyone, whether they have approved the standards or not, from: manufacturing, marketing, purchasing, or using products, processes, or procedures not conforming to the standards.

The American National Standards Institute does not develop Standards and will under no circumstances give an interpretation of any American National Standard. Moreover, no person shall have the right or authority to issue an interpretation of an American National Standard in the name of the American National Standards Institute. Requests for interpretations should be addressed to the secretary or sponsor whose name appears on the title page of this standard.

Caution Notice: This American National Standard may be revised or withdrawn at any time. The procedures of the American National Standards Institute require that action be taken periodically to reaffirm, revise, or withdraw this Standard. Purchasers of American National Standards may receive current information on all Standards by calling or writing the American National Standards Institute.

Published by

National Electrical Manufacturers Association
1300 North 17th Street, Rosslyn, VA 22209

© 2019 National Electrical Manufacturers Association

All rights reserved including translation into other languages, reserved under the Universal Copyright Convention, the Berne Convention for the Protection of Literary and Artistic Works, and the International and Pan American Copyright Conventions.

No part of this publication may be reproduced in any form, in an electronic retrieval system or otherwise, and without the prior written permission of the publisher.

Printed in the United States of America.

<This page intentionally left blank.>

Currently in preview, click buy full version

CONTENTS

Clause	TITLE	Page
	Introduction	1
1	Scope	2
2	References	4
3	Definitions	4
4	Mechanical Requirements	
4.1	General	5
4.2	Dimensions	6
4.2.1	Luminaire Extension Module (LEX-M)	6
4.2.2	Luminaire Extension Receptacle (LEX-R)	7
4.2.3	Luminaire Extension Cap (LEX-C)	8
4.3	Orientation	8
4.4	Mechanical Interface with the Luminaire	9
4.5	Ingress Protection	9
5	Electrical Requirements	10
6	Performance	12
6.1	General	12
6.2	Interchangeability Tests—Mechanical	13
6.3	Low-Temperature Impact Test	13
6.4	Rain test	14
6.5	Weathering test (exposure to UV)	14
6.6	Salt Spray (Fog) test	14
6.7	Contact Resistance test	14
6.8	Normal Temperature test	15
6.9	Dielectric Voltage Withstand test	15
6.10	Insulation Resistance test	15
6.11	Wire Terminal Pull-out test	16
6.12	Wire Strain Relief test	16
6.13	Ingress Protection Rating (IP)	16
7	Marking	16
7.1	General	16
7.2	Normative Markings	17
7.3	Optional Markings	17
7.4	Instructions	17
Figure	FIGURES	ref.to:
1.1A	Luminaire Extension Module	1.1 3.2
1.1B	Luminaire Extension Receptacle	1.1 3.3 4.1.1

1.1C 1.2	Luminaire Extension Cap Mounting Option	1.1 3.4
1.6	LEX-R, LEX-M (or LEX-C) in a system with luminaire	1.1 1.6 3.2, 3.3, 3.4 4.2.2.5 4.3.2 6.4.1b)
4.2.1	LEX-M – Maximum dimensions (bottom or side-mounted)	3.7 4.2.1.2
4.2.2	LEX-R - overall dimensions and coupling with LEX-M (or LEX-C)	3.7 4.2.1.4 4.2.2.1 4.5.2 5.3
4.3	Orientation for LEX-R and LEX-M in street lighting applications	3.1
6.7	Contact Resistance testing	6.7.5
7.3.1	Directional indicator	7.3.1
Table	TABLES	ref.to:
5.1	Assignments of contacts in LEX-M and LEX-R	5.1 5.3 7.3.1
5.7	LEX-M and LEX-R contact plating composition	5.7
6.1	Sequence of tests	6.1.1, 6.1.2, 6.1.3 6.2
6.11	Pull force	6.11.1

FOREWORD

At the time this Standard was approved the ANSI C136 committee was composed of the following Members:

Acuity Brands, Inc.	LED Roadway Lighting Ltd.
Alabama Power Company	Legrand, North America
Atlas Lighting Products, Inc.	Leoteck Electronics USA Corp
California Lighting Technology Center University of California Davis	Light Smart
CIMCON Lighting	Littelfuse, Inc.
City of Kansas City, Missouri	Lumispec Consulting.
City of Los Angeles, Bureau of Street Lighting	National Grid
Cree, Inc.	OSRAM SYLVANIA, Inc.
Current Lighting Solutions, LLC	Pacific Northwest National Laboratory
Dominion Energy	Phoenix Lighting
Duke Energy	PNNL-Battelle
E J Kramer Consulting, LLC	PSEG Power
Eaton Lighting Solutions	Radian Research
EPRI	Ripley Lighting Controls LLC
Excellence Opto, Inc.	ROAM/DTL
EYE Lighting International of N.A., Inc.	SELC Lighting
Florida Power & Light Company	Sensus a Xylem Brand
Gateway International 360	Signify North America Corporation
GE Lighting	South Carolina Electric & Gas
Georgia Power Company	Stresscrete/king Luminaire
Graeme Lister Consulting	Sunrise Technologies, Inc.
Greenstar Products, Inc.	Tamp Electric
Hancock Consulting	TE Connectivity
Hapco Aluminum Pole Products	TICO
Howard Lighting	Telematic Wireless
Hubbell Lighting, Inc.	Telensa
Intelligent Illuminations Inc.	Utility Metals Division of Fabricated Metals, LLC
Intermatic Incorporated	Valmont Composite Structures
Intertek USA, Inc.	Valmont Industries, Inc.
Itron, Inc.	Vandal Sheilds
JEA	Wathour Engineering Company
Kauffman Consulting, LLC	Westire Technology Limited
	Xcel Energy

<This page intentionally left blank.>

Currently in preview, click buy full version

Luminaire Four-Pin Extension Module and Receptacle—Physical and Electrical Interchangeability and Testing

Introduction

The need for an upgradeable, intelligent luminaire having a more diverse range of functions (connectivity, sensors) has resulted in the need to develop the luminaire four-pin extension module and receptacle. The smaller footprint of the receptacle supports the miniaturization trend of LED luminaires.

Precedence

This Standard in its parts refers to ANSI C137.4—*Digital Interface with Auxiliary Power for Devices*, for the electrical interconnection between the receptacle and the driver.

In the case of any perceived discrepancy between the definitions and requirements provided in Referenced Publications (RP) and this Standard, the definitions provided in this Standard take precedence over the definitions and requirements provided in RPs.

Where the requirements of any of the clauses of RP are referred to in this Standard by the phrase “The requirements of Clause n of C136. (or RP) apply.”

1 Scope

1.1 This document defines the following roadway and area lighting equipment, which may be physically and electrically interchanged to operate within established values:

- a. A locking type 4-pin Luminaire Extension Module (LEX-M),
- b. A locking type mating 4-pin Luminaire Extension Receptacle (LEX-R),
- c. A Luminaire Extension Cap (LEX-C),

Notes:

Figures 1.1A, 1.1B, and 1.1C show informative 3D-model renderings of these components. Figure 1.6 gives an overview of a Luminaire with a LEX-R, LEX-M, or LEX-C.



Figure 1.1A: Luminaire Extension Module (bottom / top view-example only)

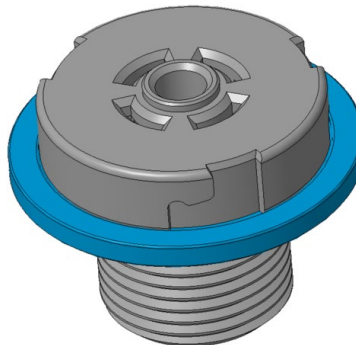

Figure 1.1B: Luminaire Extension Receptacle (top view)

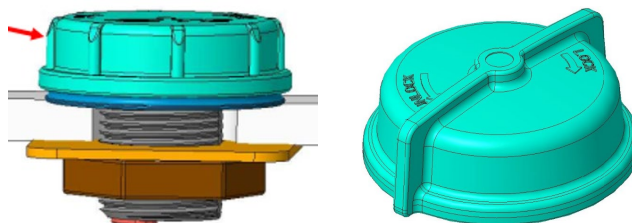

Figure 1.1C: Luminaire Extension Cap

1.2 The equipment in 1.1 is primarily intended for outdoor application, although it may also be used indoors.