

ACI 550.2R-13

**Design Guide for Connections in
Precast Jointed Systems**

Reported by Joint ACI-ASCE Committee 550



American Concrete Institute®



American Concrete Institute®
Advancing concrete knowledge

First Printing
April 2013

Design Guide for Connections in Precast Jointed Systems

Copyright by the American Concrete Institute, Farmington Hills, MI. All rights reserved. This material may not be reproduced or copied, in whole or part, in any printed, mechanical, electronic, film, or other distribution and storage media, without the written consent of ACI.

The technical committees responsible for ACI committee reports and standards strive to avoid ambiguities, omissions, and errors in these documents. In spite of these efforts, the users of ACI documents occasionally find information or requirements that may be subject to more than one interpretation or may be incomplete or incorrect. Users who have suggestions for the improvement of ACI documents are requested to contact ACI via the errata website at www.concrete.org/committees/errata.asp. Proper use of this document includes periodically checking for errata for the most up-to-date revisions.

ACI committee documents are intended for the use of individuals who are competent to evaluate the significance and limitations of its content and recommendations and who will accept responsibility for the application of the material it contains. Individuals who use this publication in any way assume all risk and accept total responsibility for the application and use of this information.

All information in this publication is provided "as is" without warranty of any kind, either express or implied, including but not limited to, the implied warranties of merchantability, fitness for a particular purpose or non-infringement.

ACI and its members disclaim liability for damages of any kind, including any special, indirect, incidental, or consequential damages, including without limitation, lost revenues or lost profits, which may result from the use of this publication.

It is the responsibility of the user of this document to establish health and safety practices appropriate to the specific circumstances involved with its use. ACI does not make any representations with regard to health and safety issues and the use of this document. The user must determine the applicability of all regulatory limitations before applying the document and must comply with all applicable laws and regulations, including but not limited to, United States Occupational Safety and Health Administration (OSHA) health and safety standards.

Participation by governmental representatives in the work of the American Concrete Institute and in the development of Institute standards does not constitute governmental endorsement of ACI or the standards that it develops.

Order information: ACI documents are available in print, by download, on CD-ROM, through electronic subscription, or reprint and may be obtained by contacting ACI.

Most ACI standards and committee reports are gathered together in the annually revised *ACI Manual of Concrete Practice* (MCP).

American Concrete Institute
38801 Country Club Drive
Farmington Hills, MI 48331
U.S.A.
Phone: 248-848-3700
Fax: 248-848-3701

www.concrete.org

ISBN-13: 978-0-87031-812-2
ISBN: 0-87031-812-8

Design Guide for Connections in Precast Jointed Systems

Reported by Joint ACI-ASCE Committee 550

Thomas J. D'Arcy, Chair

Te-Lin Chung
Ned M. Cleland
William K. Doughty
Alvin C. Ericson
Melvyn A. Galinat
Harry A. Gleich

Mohammad S. Habib
Neil M. Hawkins
Augusto H. Holmberg
L. S. Paul Johal
Jason J. Krohn
Emily B. Lorenz

Kenneth A. Luttrell
Vilas S. Mujumdar
Frank A. Nadeau
Clifford R. Ohlwiler
Victor F. Pizano-Thomen
Jose I. Restrepo

Sanjay H. Rizkalla
Mario E. Rodriguez
Joseph C. Sanders
John F. Stanton
P. Jeffrey Wang
Cloyd E. Warnes

The proper detailing and design of precast concrete connections are essential to the performance of a precast concrete structure. This guide provides information on design, detailing, and construction of connections between precast members in jointed systems, including moment frame and structural wall systems.

Keywords: bolting; connection; debonding; ductility; erection; moment frame; precast; pretopped; post-tensioning; structural walls; welding.

CONTENTS

CHAPTER 1—INTRODUCTION AND SCOPE, p. 1

- 1.1—Introduction, p. 2
- 1.2—Scope, p. 2

CHAPTER 2—NOTATION AND DEFINITIONS, p. 2

- 2.1—Notation, p. 2
- 2.2—Definitions, p. 2

CHAPTER 3—GUIDELINES FOR DESIGN, p. 3

- 3.1—Classes of connections, p. 3
- 3.2—Principles of connection design, p. 3
- 3.3—Anchorage to concrete, p. 5
- 3.4—Welding, p. 5

- 3.5—Debonding, p. 7

CHAPTER 4—PRECAST CONCRETE FLOOR SYSTEMS, p. 7

- 4.1—Precast systems, p. 7
- 4.2—Precast floor diaphragms, p. 7

CHAPTER 5—LATERAL-LOAD-RESISTING SYSTEMS, p. 8

- 5.1—Structural walls, p. 8
- 5.2—Structural walls with large openings, p. 8
- 5.3—Moment frames, p. 8

CHAPTER 6—CONNECTIONS, p. 10

- 6.1—Strength, p. 10
- 6.2—Ductility, p. 10
- 6.3—Volume change accommodation, p. 11
- 6.4—Durability, p. 11
- 6.5—Fire resistance, p. 11
- 6.6—Constructibility, p. 11
- 6.7—Aesthetics, p. 11
- 6.8—Seismic requirements, p. 11
- 6.9—Tolerances, p. 11
- 6.10—Vertical connections, p. 11

CHAPTER 7—ERECTION CONSIDERATIONS, p. 13

CHAPTER 8—WELDING CONSIDERATIONS, p. 13

- 8.1—Steel assemblies, p. 13

ACI Committee Reports, Guides, and Commentaries are intended to provide guidance in planning, designing, executing, and inspecting construction. This document is intended for the use of individuals who are competent to evaluate the significance and limitations of its content and recommendations and who will accept responsibility for the application of the material it contains. The American Concrete Institute disclaims any and all responsibility for the stated principles. The Institute shall not be liable for any loss or damage arising therefrom.

Reference to this document shall not be made in contract documents. If items found in this document are desired by the Architect/Engineer to be a part of the contract documents, they shall be restated in mandatory language for incorporation by the Architect/Engineer.

ACI 550.2R-13 was adopted and published April 2013.
Copyright © 2013, American Concrete Institute.

All rights reserved including rights of reproduction and use in any form or by any means, including the making of copies by any photo process, or by electronic or mechanical device, printed, written, or oral, or recording for sound or visual reproduction or for use in any knowledge or retrieval system or device, unless permission in writing is obtained from the copyright proprietors.

- 8.2—Galvanized steel, p. 13
- 8.3—Stainless steel, p. 14
- 8.4—Reinforcement, p. 14
- 8.5—Welding practices for epoxy-coated material, p. 15

CHAPTER 9—GROUTING, p. 15

CHAPTER 10—REFERENCES, p. 15

CHAPTER 1—INTRODUCTION AND SCOPE

1.1—Introduction

Precast concrete structural systems are composed of individually fabricated components. Because of the segmental nature of precast concrete construction, connections between individual components are required to support the design loads. Connections are also required to accommodate deformations, including rotations and strains.

1.1.1 Connection methods—Precast components are connected by one of two methods. The first method connects components by reinforcement that protrudes from each component end, spliced using proprietary hardware or by lap-splicing with a small quantity of cast-in-place concrete to complete the connection. This method is referred to as emulation, or a wet connection, because it involves field-placed cast-in-place concrete and mimics the behavior of cast-in-placed monolithic structures. The second, more-common, method of connection is dry and connects components by welding, bolting, post-tensioning, or doweling without using field-placed concrete. Because dry connections are typically less stiff than their connecting precast components, deformations tend to be concentrated in the connections.

Connections should allow for easy and economical component casting and assembly, fabrication, erection tolerance, and erection tolerances. They should also tolerate anticipated deformation without significant loss of strength.

1.1.2 Connection groups—Connections are categorized into five groups:

- 1) **Gravity load transfer**—Gravity loads alone, such as hollow core members placed on a bearing ledge
- 2) **Shear transfer**—Either vertical shear, horizontal shear, or both, such as a double-tee flange-to-flange connection
- 3) **Moment transfer**—The tension and compression forces created by moment, such as a connection between a precast moment frame and its foundation
- 4) **Structural integrity**—Code-prescribed structural integrity forces, typically a connection with combination accommodations
- 5) **Combination connection**—A combination of loads, such as moments and shear

In all cases, the load paths and external loads are accommodated in all elements of connections (Fig. 1.1.2).

Tying all precast members to each adjacent member is essential for structural integrity as required by Chapter 16 of ACI 318-11. Such connections, however, should not be so rigid as to prevent member rotation or volume change strains when required.

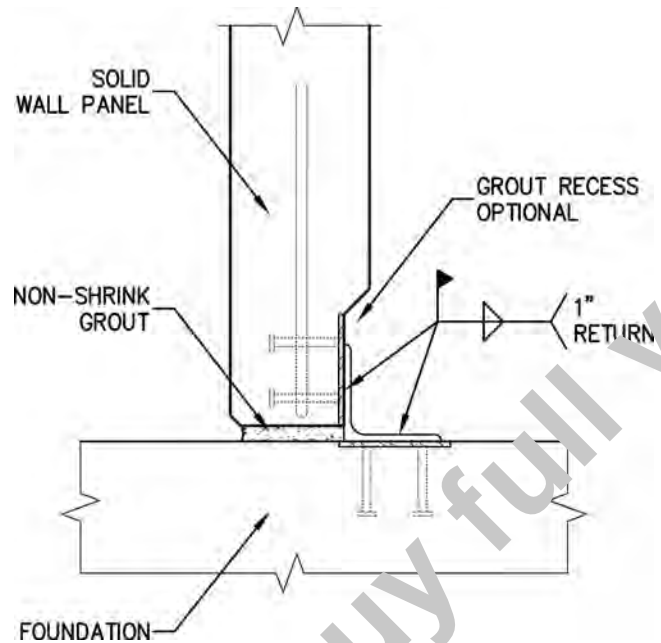

Fig. 1.1.2—Wall panel foundation connection.

1.2—Scope

This guide provides information on the characteristics and design of connections between precast concrete components and between precast components and cast-in-place construction. The proper detailing and design of precast concrete connections are essential to the performance of a precast concrete structure.

This guide describes typical precast jointed systems and their connection types, performance, and characteristics, and provides recommendations for design and construction. Three classes of connections are identified and their characteristic and key design considerations given. Also included are guidelines for designing connections and their anchorage, a description of precast systems, typical lateral-load-resisting systems, key design considerations, and erection requirements including special welding considerations.

CHAPTER 2—NOTATION AND DEFINITIONS

2.1—Notation

- C_d = deflection amplification factor
- f'_c = specified compressive strength of concrete, psi (MPa)
- R = response modification factor
- ϕ = strength reduction factor

2.2—Definitions

ACI provides a comprehensive list of definitions through an online resource, “ACI Concrete Terminology,” <http://terminology.concrete.org>. Definitions provided herein complement that resource.

deformable connection—a class of connection between precast members designed to either display significant flexibility or to yield, without losing strength, when subjected to expected deformations.